

DIMENSIONAL GRAPHICS
 PHONE & FAX (650) 342-5724
 kenny@dimensionalgraphics.com
 www.dgflow.com
MATERIAL CALLOUTS ARE TO CLARIFY THE DESIGN INTENT. ALL DESIGN CONCEPTS AND MATERIALS MUST BE VERIFIED BY A LICENSED ENGINEER.

RIGGED TO FLY.

ALL FLATS ARE 1-5/16" x 2-1/4" ON EDGE CONSTRUCTION COVERED ON DS FACE WITH 1/4" LAUAN OR SIMILAR PANEL.

FLATS EXCEEDING 16' SHOULD BE SCARFED

Parts List			
ITEM	QTY	PART NUMBER	DESCRIPTION
1	4	MF-A1 Panel 2 Col 1	SHEET A1-P10 VIEWS 1,4

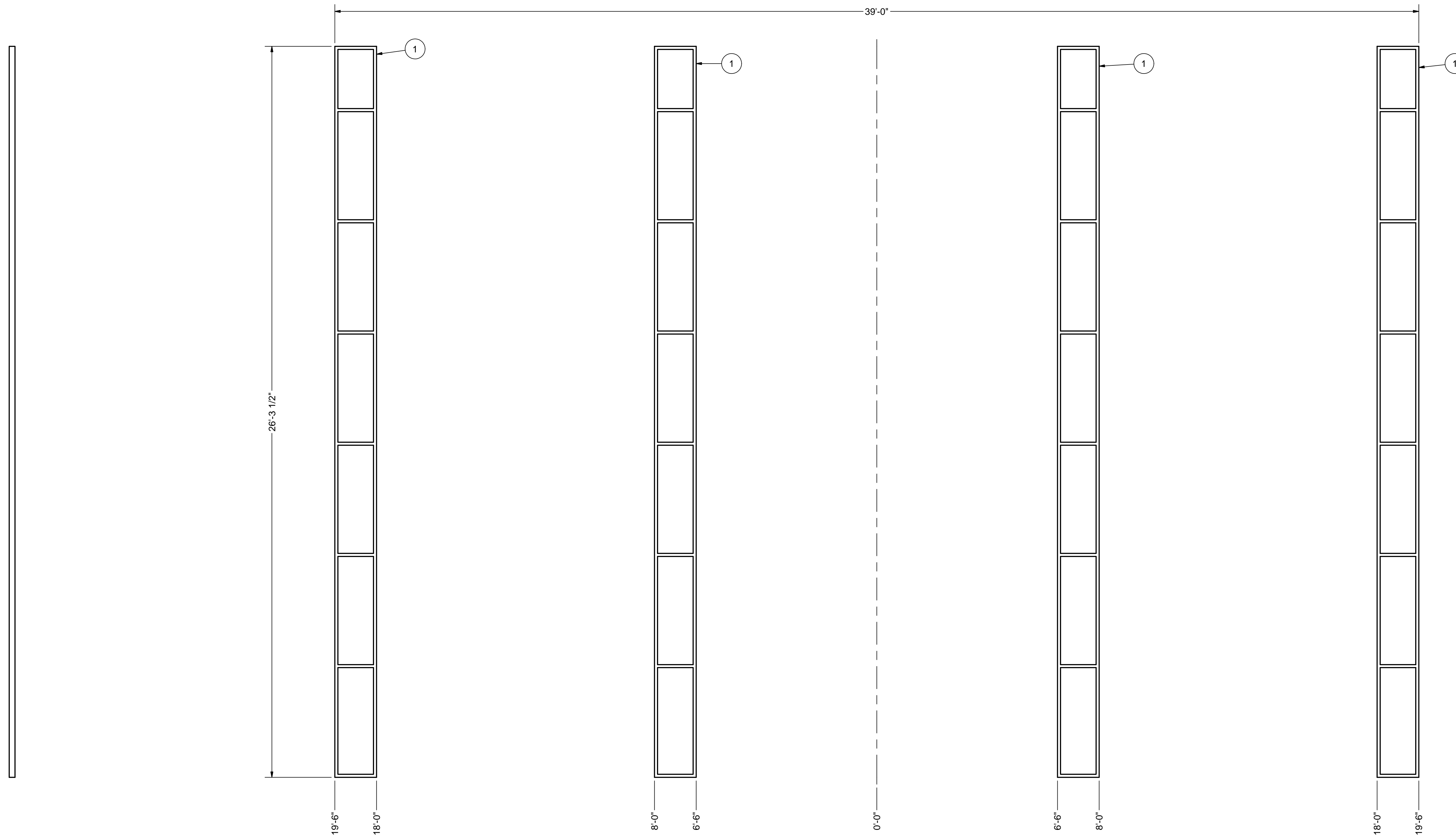

1 PANEL 2 - SL VIEW
1/2"=1'-0"

2 PANEL 2 - US VIEW
1/2"=1'-0"

ACT 1 PANEL 2 LAYOUT
 SAN FRANCISCO OPERA
 MAGIC FLUTE 2012

REFERENCED	
FROM	TO

JOB ID: _____
 DRAWN BY: Ken Sly
 APPROVED BY: _____
 ORIGINAL DATE: 1/19/2012
 DUE DATE: _____
 SCALE: 1/2"=1'-0"

A1 P2
 LATEST REVISION: 2/6/2012 **B**

REV B: CHANGED LUMBER SPECS.

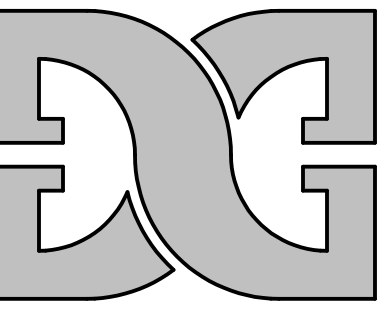

DIMENSIONAL GRAPHICS

PHONE & FAX (650) 342-5724
ken@diglow.com
www.diglow.com

MATERIAL CALLOUTS ARE TO CLARIFY THE DESIGN INTENT. ALL DESIGN CONCERNS AND MATERIALS MUST BE VERIFIED BY A LICENSED ENGINEER.

TYPICAL ALL FLATS:
ALL FLATS ARE 1-5/16" x 2-1/4" ON EDGE CONSTRUCTION
COVERED ON DS FACE WITH 1/4" LAUAN OR SIMILAR PANEL.
FLATS EXCEEDING 16' SHOULD USE SCARFED BATTENS.

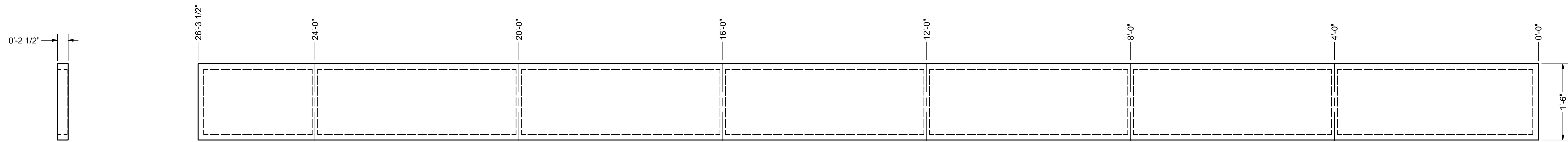

1 TOP VIEW
1"=1'-0"

- 2 PANEL 1 COL 1 - DS FACE
1"=1'-0"
2 REQUIRED
- 3 PANEL 1 COL 2 - DS FACE
1"=1'-0"
2 REQUIRED
- 4 PANEL 2 COL 1 - DS FACE
1"=1'-0"
4 REQUIRED

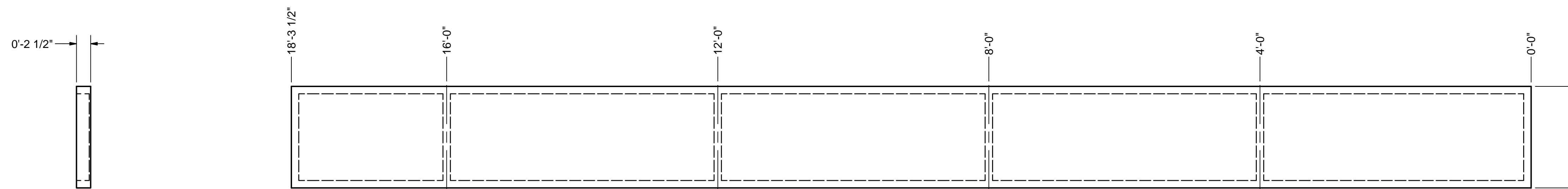

5 PANEL 1 COL 3 - TOP VIEW
1"=1'-0"
4 REQUIRED

6 PANEL 1 COL 4 - DS FACE
1"=1'-0"
4 REQUIRED

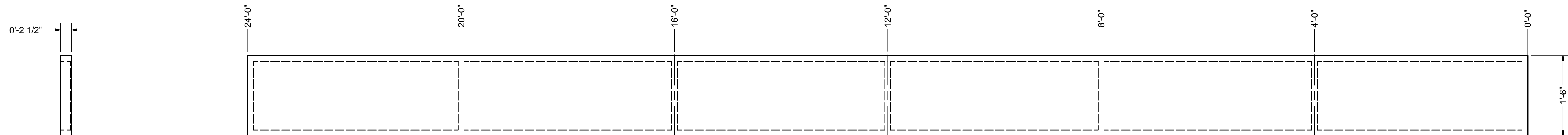

7 PANEL 1 BEAM 1 - SR END
1"=1'-0"
1 REQUIRED

8 PANEL 1 BEAM 1 - DS FACE
1"=1'-0"
1 REQUIRED

ACT 1 PANEL FLATS
SAN FRANCISCO OPERA
MAGIC FLUTE 2012

REFERENCED	
FROM	TO

JOB ID: _____
 DRAWN BY: Ken Sly
 APPROVED BY: _____
 ORIGINAL DATE: 1/19/2012
 DUE DATE: _____
 SCALE: 1"=1'-0"

A1 P10
 LATEST REVISION: 2/6/2012 B

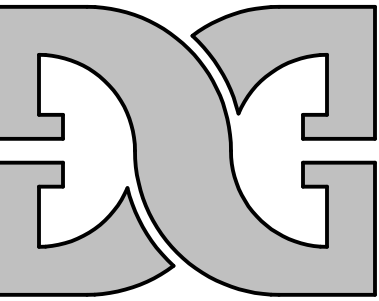

DIMENSIONAL GRAPHICS
 PHONE & FAX (650) 342-5724
 kensly@dimensionalgraphics.com
 www.dgflow.com
MATERIAL CALLOUTS ARE TO CLARIFY THE DESIGN INTENT. ALL DESIGN CONCEPTS AND MATERIALS MUST BE VERIFIED BY A LICENSED ENGINEER.

ACT 1 PANEL FLATS
SAN FRANCISCO OPERA
MAGIC FLUTE 2012

TYPICAL ALL FLATS:
 ALL FLATS ARE 1-5/16" x 2-1/4" ON EDGE CONSTRUCTION COVERED ON DS FACE WITH 1/4" LAUAN OR SIMILAR PANEL. FLATS EXCEEDING 16' SHOULD USE SCARFED BATTENS.

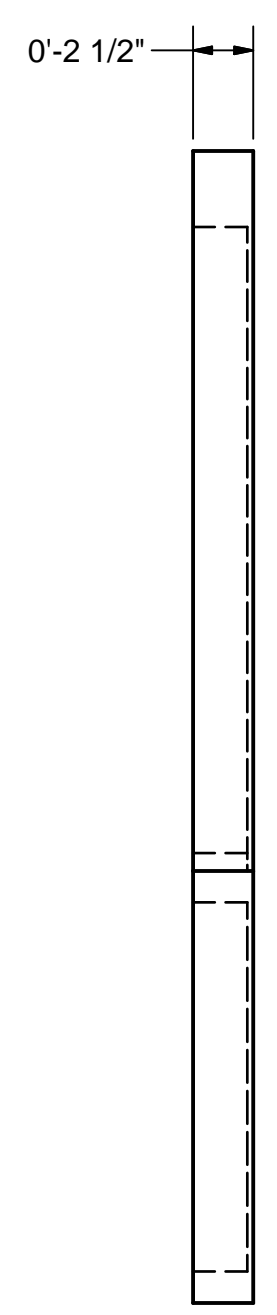

① **PANEL 1 BEAM SR - SR END**
 1-1/2"=1'-0"
 1 AS SHOWN, 1 R&R AS BEAM SL

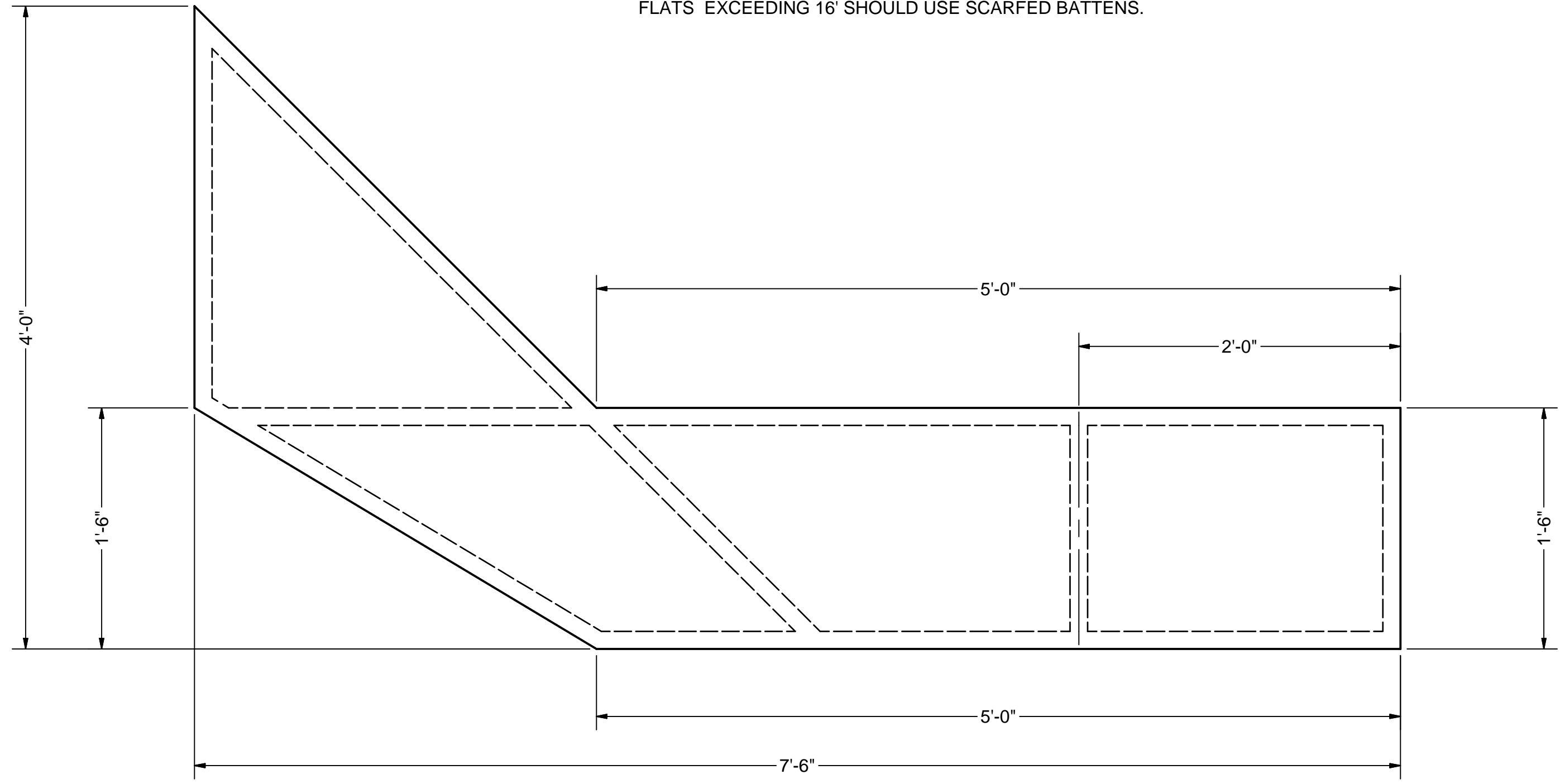

① **PANEL 1 BEAM SR - DS FACE**
 1-1/2"=1'-0"
 1 AS SHOWN, 1 R&R AS BEAM SL

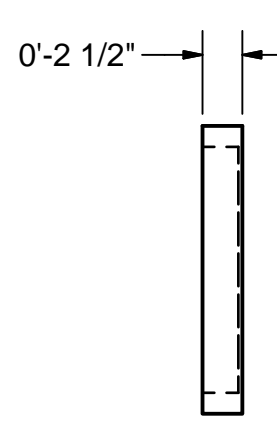

③ **PANEL 3 COL 1 - TOP VIEW**
 1"=1'-0"
 2 REQUIRED

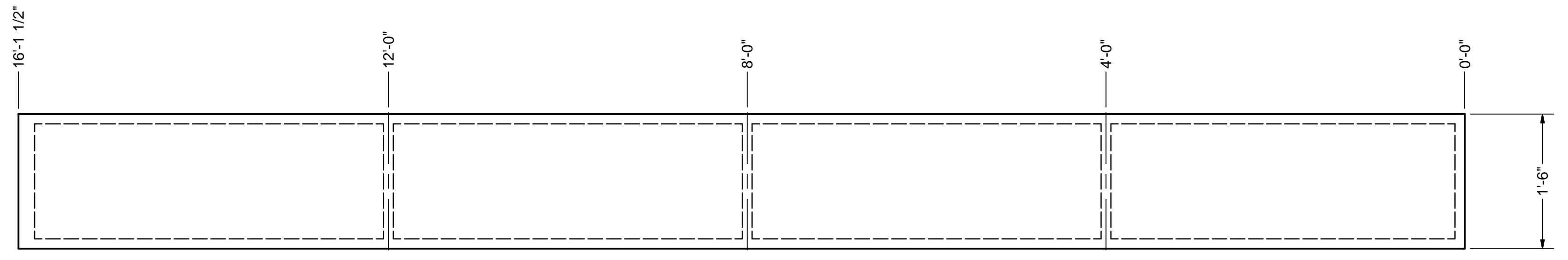

④ **PANEL 3 COL 1 - DS FACE**
 1"=1'-0"
 2 REQUIRED

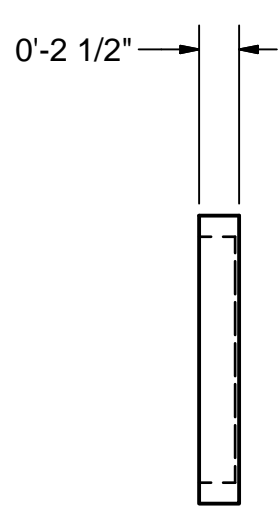

⑤ **PANEL 3 COL 2 - TOP VIEW**
 1"=1'-0"
 2 REQUIRED

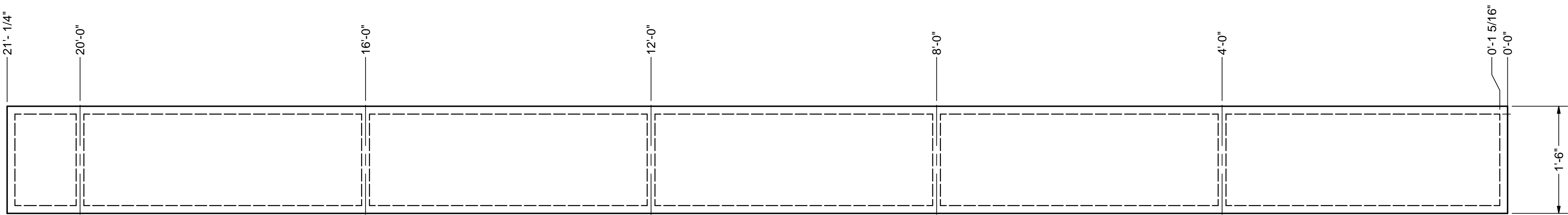

⑥ **PANEL 3 COL 2 - DS FACE**
 1"=1'-0"
 2 REQUIRED

REFERENCED	
FROM	TO

JOB ID: _____
 DRAWN BY: **Ken Sly**
 APPROVED BY: _____
 ORIGINAL DATE: **1/19/2012**
 DUE DATE: _____
 SCALE: **AS NOTED**
A1 P11
 LATEST REVISION: **2/6/2012**

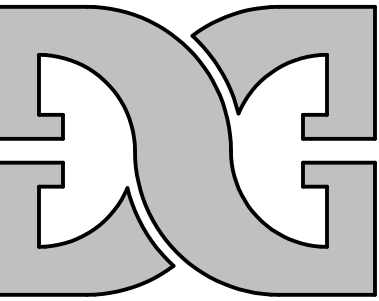

DIMENSIONAL GRAPHICS
 PHONE & FAX (650) 342-5724
 kenny@dgflow.com
 www.dgflow.com
MATERIAL CALLOUTS ARE TO CLARIFY THE DESIGN INTENT. ALL DESIGN CONCEPTS AND MATERIALS MUST BE VERIFIED BY A LICENSED ENGINEER.

ACT 1 PANEL FLATS
SAN FRANCISCO OPERA
MAGIC FLUTE 2012

TYPICAL ALL FLATS:
 ALL FLATS ARE 1-5/16" x 2-1/4" ON EDGE CONSTRUCTION
 COVERED ON DS FACE WITH 1/4" LAUAN OR SIMILAR PANEL.
 FLATS EXCEEDING 16' SHOULD USE SCARFED BATTENS.

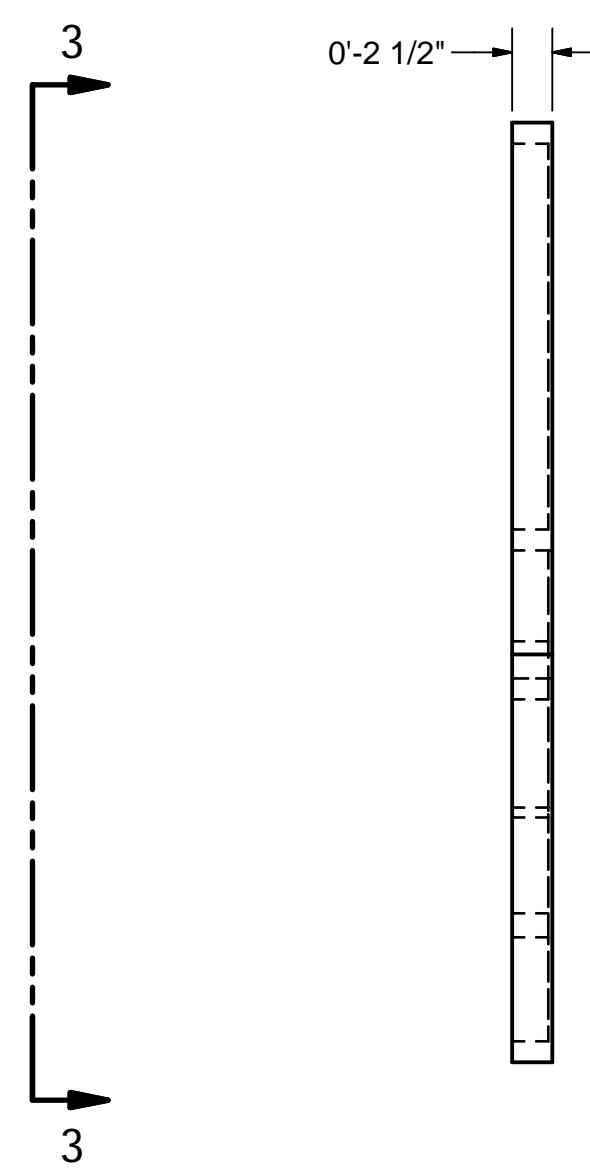

① **PANEL 3 BEAM - SR END**
 1"=1'-0"
 1 REQUIRED

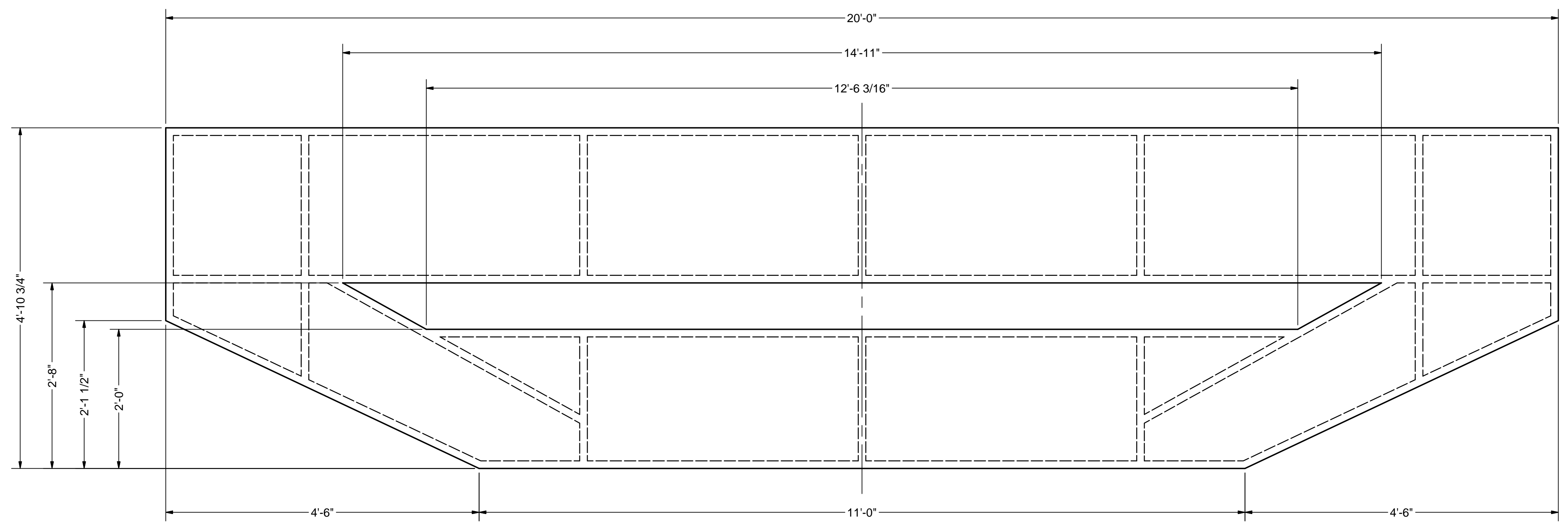

② **PANEL 3 BEAM - DS FACE**
 1"=1'-0"
 1 REQUIRED

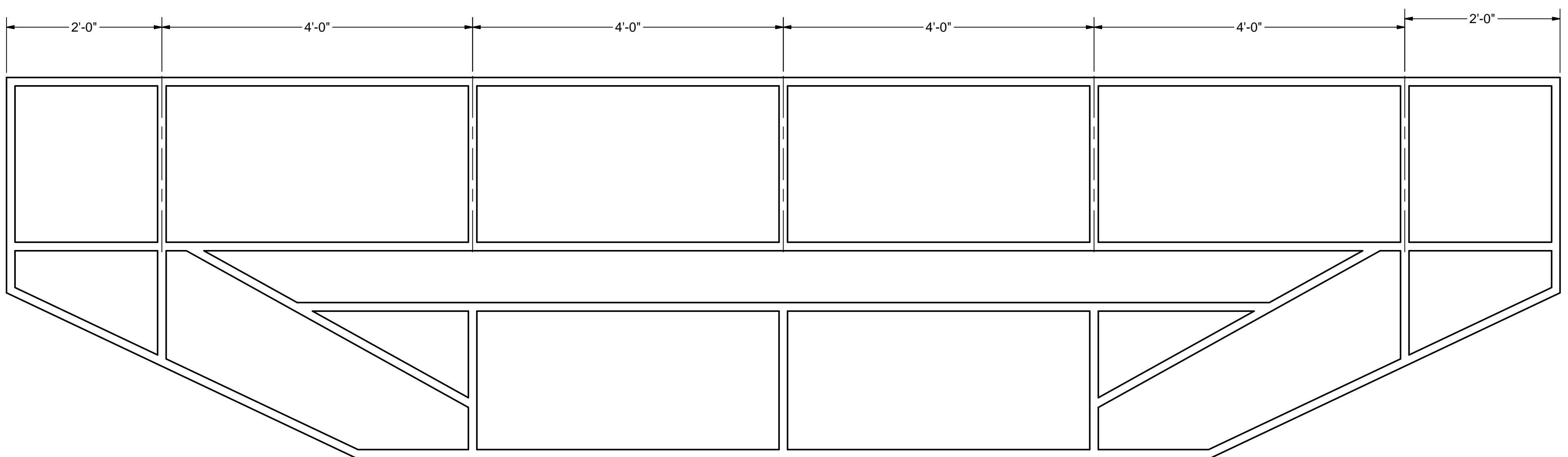

③ **PANEL 3 BEAM - US VIEW**
 1"=1'-0"
 1 REQUIRED

REFERENCED	
FROM	TO

JOB ID: _____
 DRAWN BY: Ken Sly
 APPROVED BY: _____
 ORIGINAL DATE: 1/19/2012
 DUE DATE: _____
 SCALE: AS NOTED

A1-P12
 LATEST REVISION: 2/6/2012

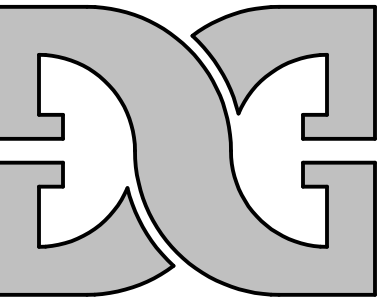

DIMENSIONAL GRAPHICS
 PHONE & FAX (650) 342-5724
 kenny@dgflow.com
 www.dgflow.com
 MATERIAL CALLOUTS ARE TO CLARIFY THE DESIGN INTENT. ALL DESIGN CONCEPTS AND MATERIALS MUST BE VERIFIED BY A LICENSED ENGINEER.

ACT 1 PANEL FLATS
SAN FRANCISCO OPERA
MAGIC FLUTE 2012

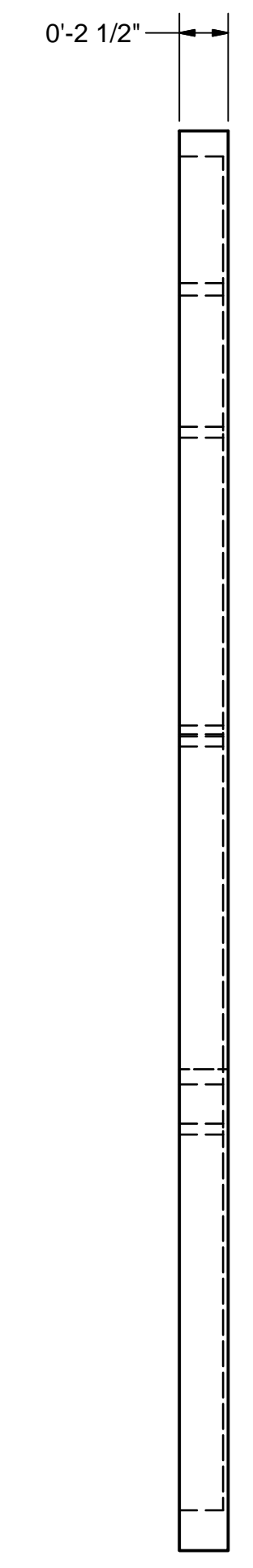
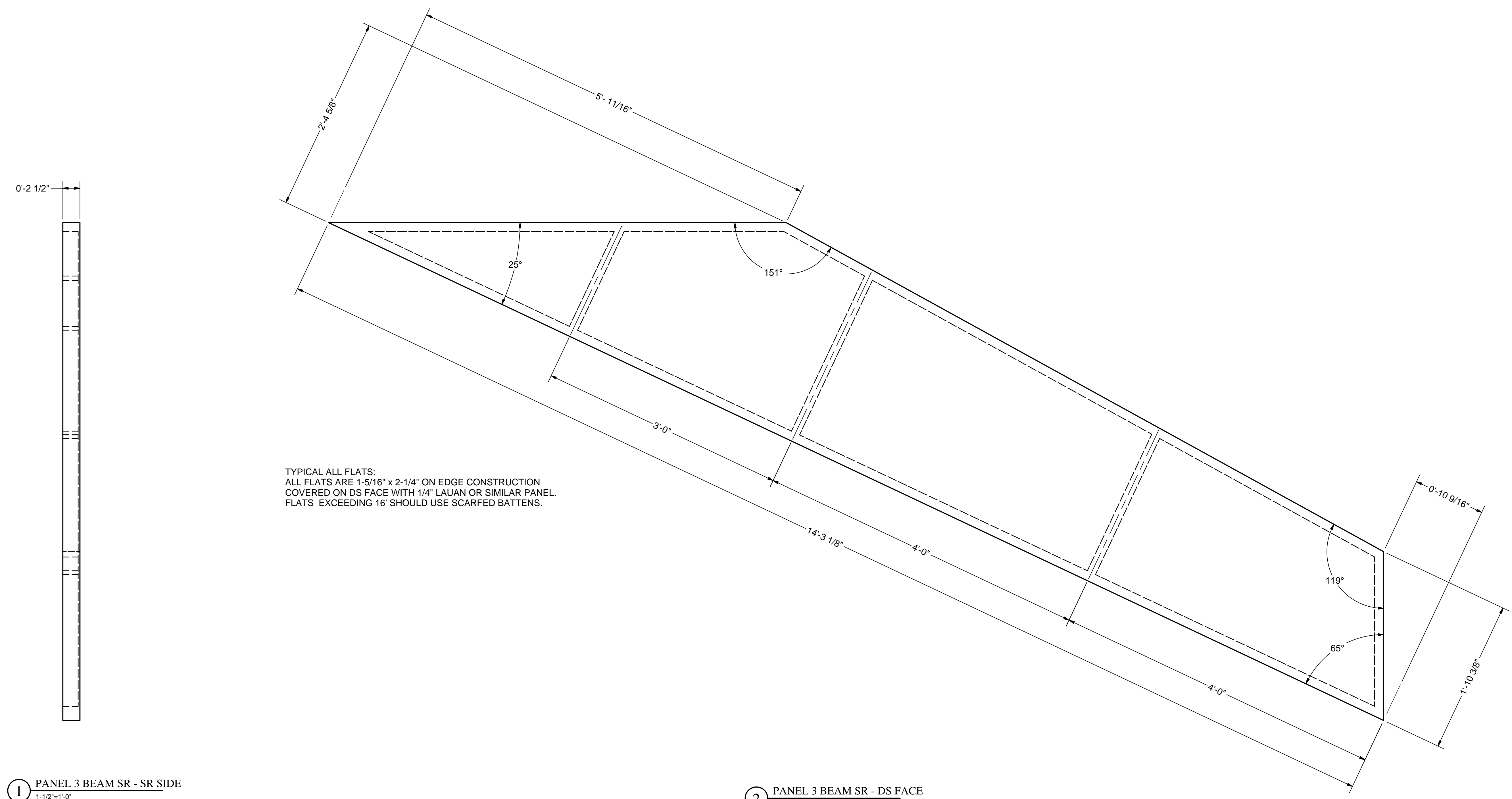

① **PANEL 3 BEAM SR - SR SIDE**
 1-1/2"=1'-0"
 1 AS SHOWN, 1 R&R AS BEAM SL

② **PANEL 3 BEAM SR - DS FACE**
 1-1/2"=1'-0"
 1 AS SHOWN, 1 R&R AS BEAM SL

REFERENCED	
FROM	TO

JOB ID: _____
 DRAWN BY: Ken Sly
 APPROVED BY: _____
 ORIGINAL DATE: 1/19/2012
 DUE DATE: _____
 SCALE: 1-1/2"=1'-0"

A1-P13
 LATEST REVISION: 2/6/2012 **B**

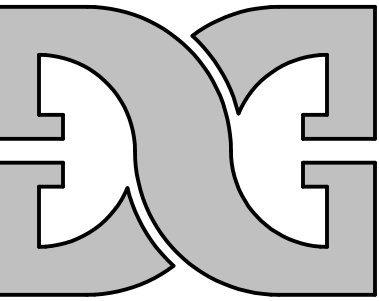

DIMENSIONAL GRAPHICS
 PHONE & FAX (650) 342-5724
 kensly@dimensionalgraphics.com
 www.dgflow.com
 MATERIAL CALLOUTS ARE TO CLARIFY THE DESIGN INTENT. ALL DESIGN CONCERNS AND MATERIALS MUST BE VERIFIED BY A LICENSED ENGINEER.

ACT 1 PANEL FLATS
SAN FRANCISCO OPERA
MAGIC FLUTE 2012

TYPICAL ALL FLATS:
 ALL FLATS ARE 1-5/16" x 2-1/4" ON EDGE CONSTRUCTION
 COVERED ON DS FACE WITH 1/4" LAUAN OR SIMILAR PANEL.
 FLATS EXCEEDING 16' SHOULD USE SCARFED BATTENS.

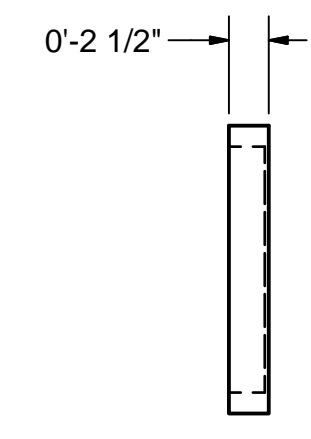

1 PANEL 4 COL 1 - TOP VIEW
 1"=1'-0"
 2 REQUIRED

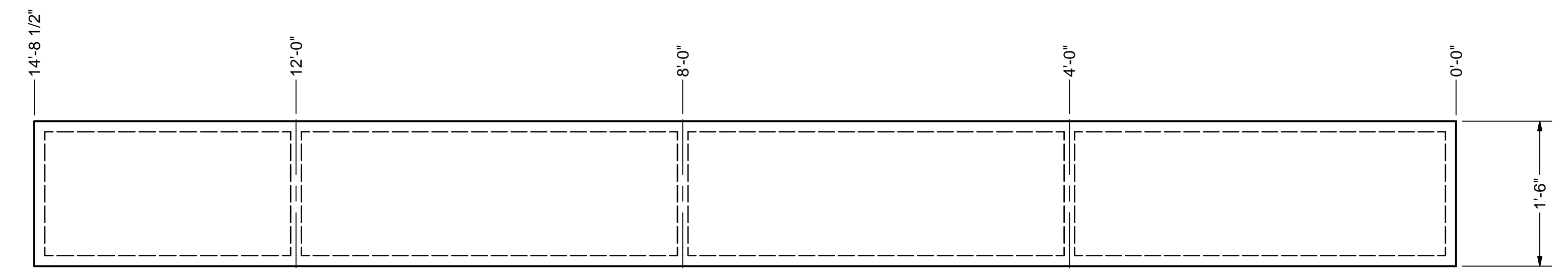

2 PANEL 4 COL 1 - DS FACE
 1"=1'-0"
 2 REQUIRED

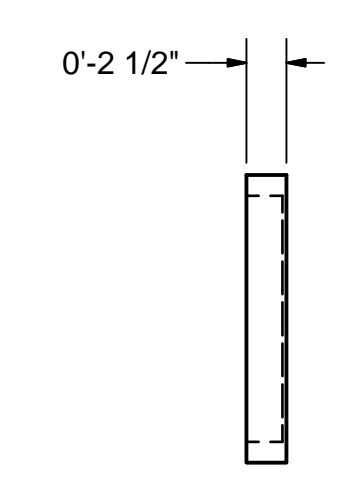

3 PANEL 4 COL 2 - TOP VIEW
 1"=1'-0"
 2 REQUIRED

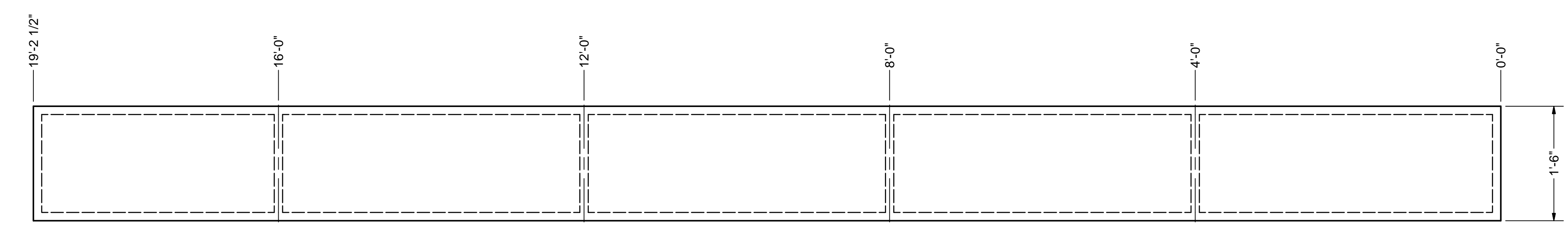

4 PANEL 4 COL 2 - DS FACE
 1"=1'-0"
 2 REQUIRED

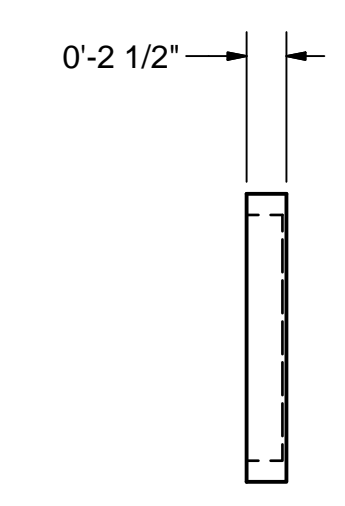

5 PANEL 4 BEAM 1 - SR END
 1"=1'-0"
 1 REQUIRED

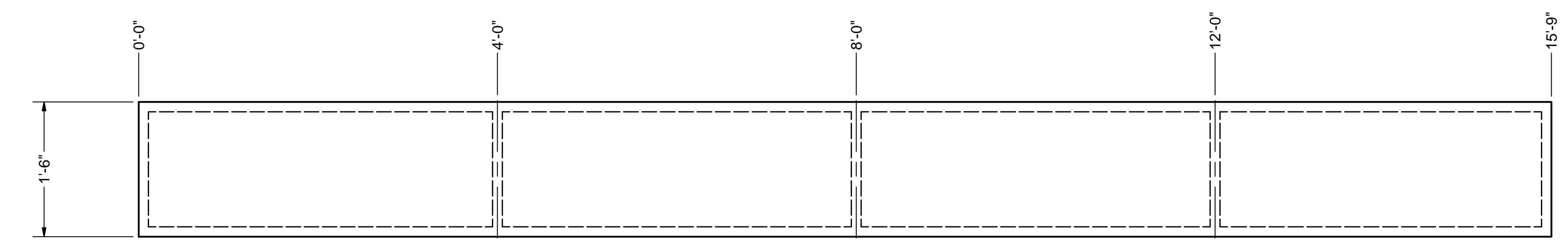

6 PANEL 4 BEAM 1 - DS FACE
 1"=1'-0"
 1 REQUIRED

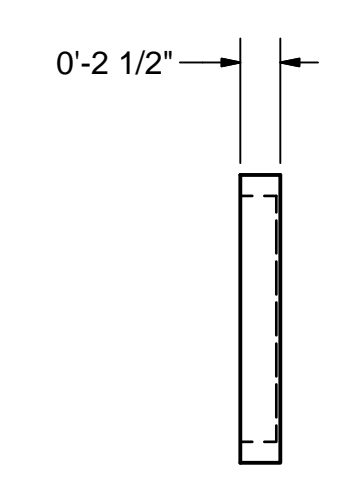

7 PANEL 4 BEAM 2 - SR END
 1"=1'-0"
 1 REQUIRED

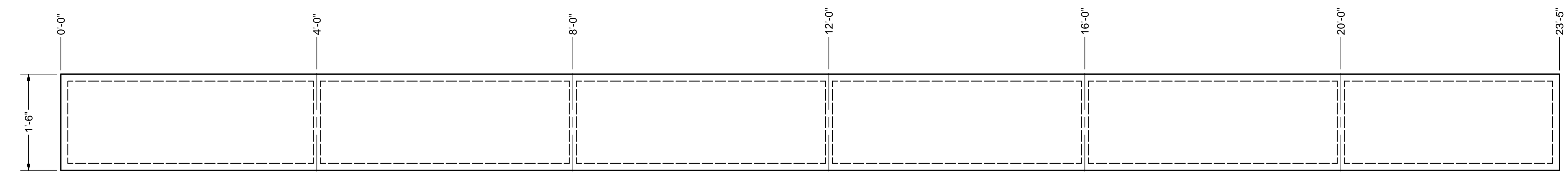

8 PANEL 4 BEAM 2 - DS FACE
 1"=1'-0"
 1 REQUIRED

REFERENCED	
FROM	TO

JOB ID: _____
 DRAWN BY: **Ken Sly**
 APPROVED BY: _____
 ORIGINAL DATE: **1/19/2012**
 DUE DATE: _____
 SCALE: **1"=1'-0"**

A1-P14
 LATEST REVISION: **2/6/2012** **B**

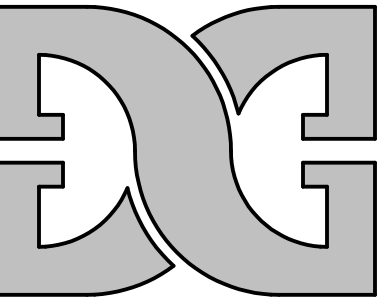

DIMENSIONAL GRAPHICS
 PHONE & FAX (650) 342-5724
 kenny@dimensional.com
 www.dgflow.com
MATERIAL CALLOUTS ARE TO CLARIFY THE DESIGN INTENT. ALL DESIGN CONCEPTS AND MATERIALS MUST BE VERIFIED BY A LICENSED ENGINEER.

ACT 1 PANEL FLATS
SAN FRANCISCO OPERA
MAGIC FLUTE 2012

TYPICAL ALL FLATS:
 ALL FLATS ARE 1-5/16" x 2-1/4" ON EDGE CONSTRUCTION
 COVERED ON DS FACE WITH 1/4" LAUAN OR SIMILAR PANEL.
 FLATS EXCEEDING 16' SHOULD USE SCARFED BATTENS.

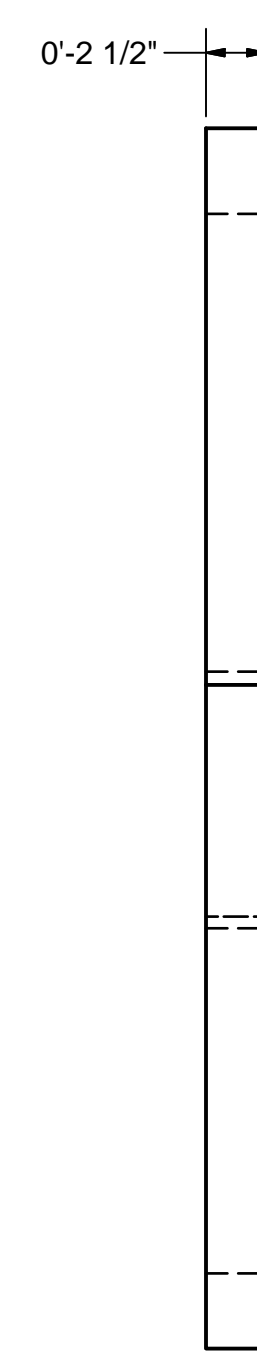

① **PANEL 4 BEAM 3 SR - SR EDGE**
 1-1/2"=1'-0"
 1 AS SHOWN, 1 R&R AS BEAM 3 SL

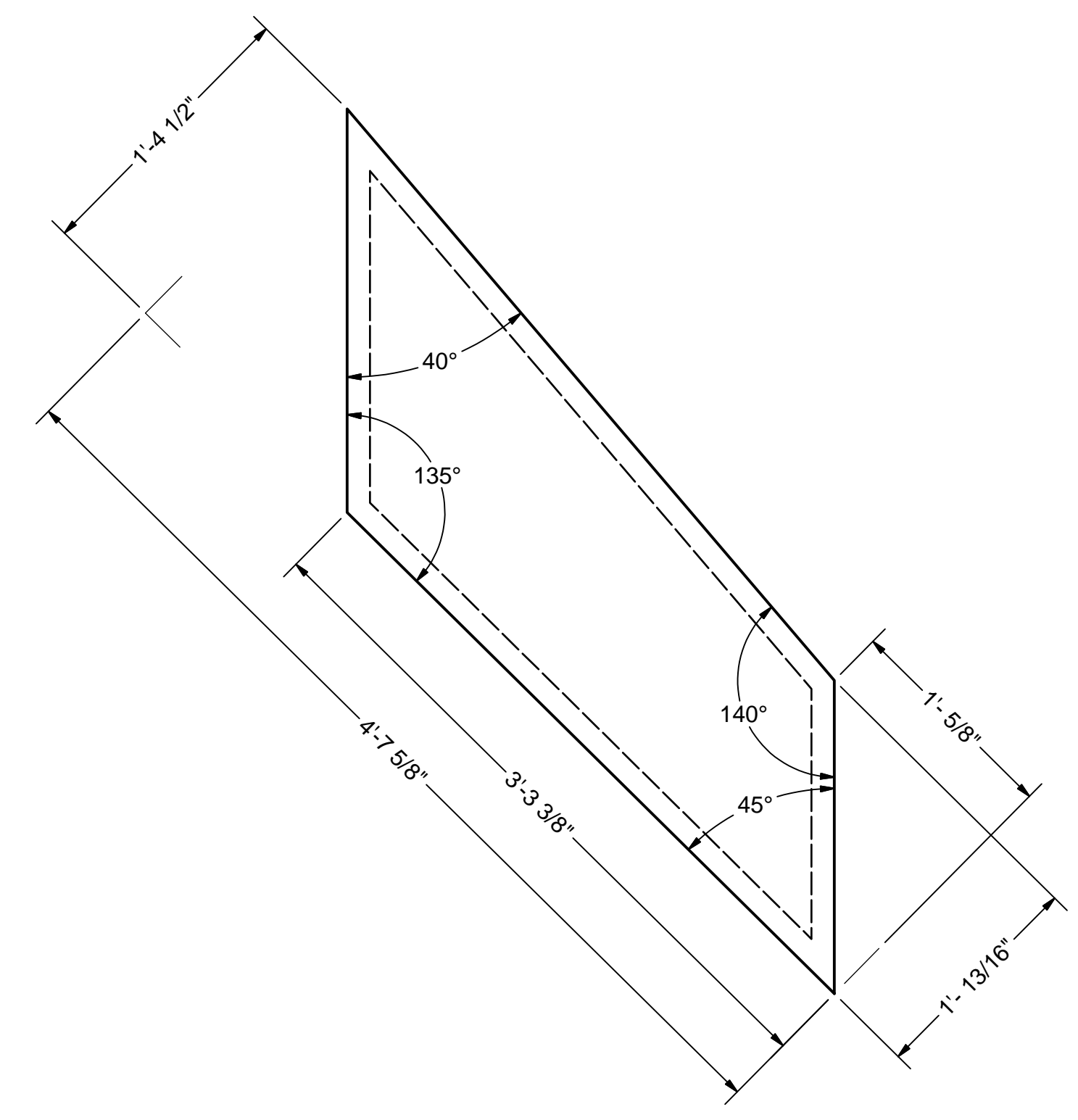

② **PANEL 4 BEAM 3 SR - DS FACE**
 1-1/2"=1'-0"
 1 AS SHOWN, 1 R&R AS BEAM 3 SL

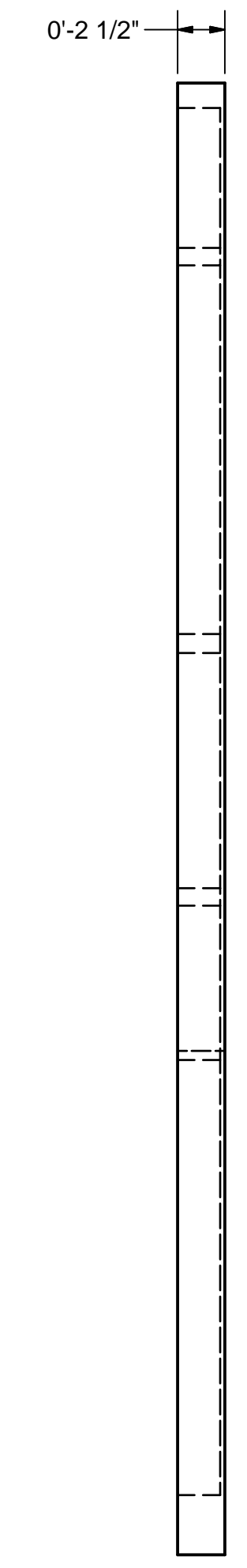

③ **PANEL 4 BEAM 4 SR - SR EDGE**
 1-1/2"=1'-0"
 1 AS SHOWN, 1 R&R AS BEAM 4 SL

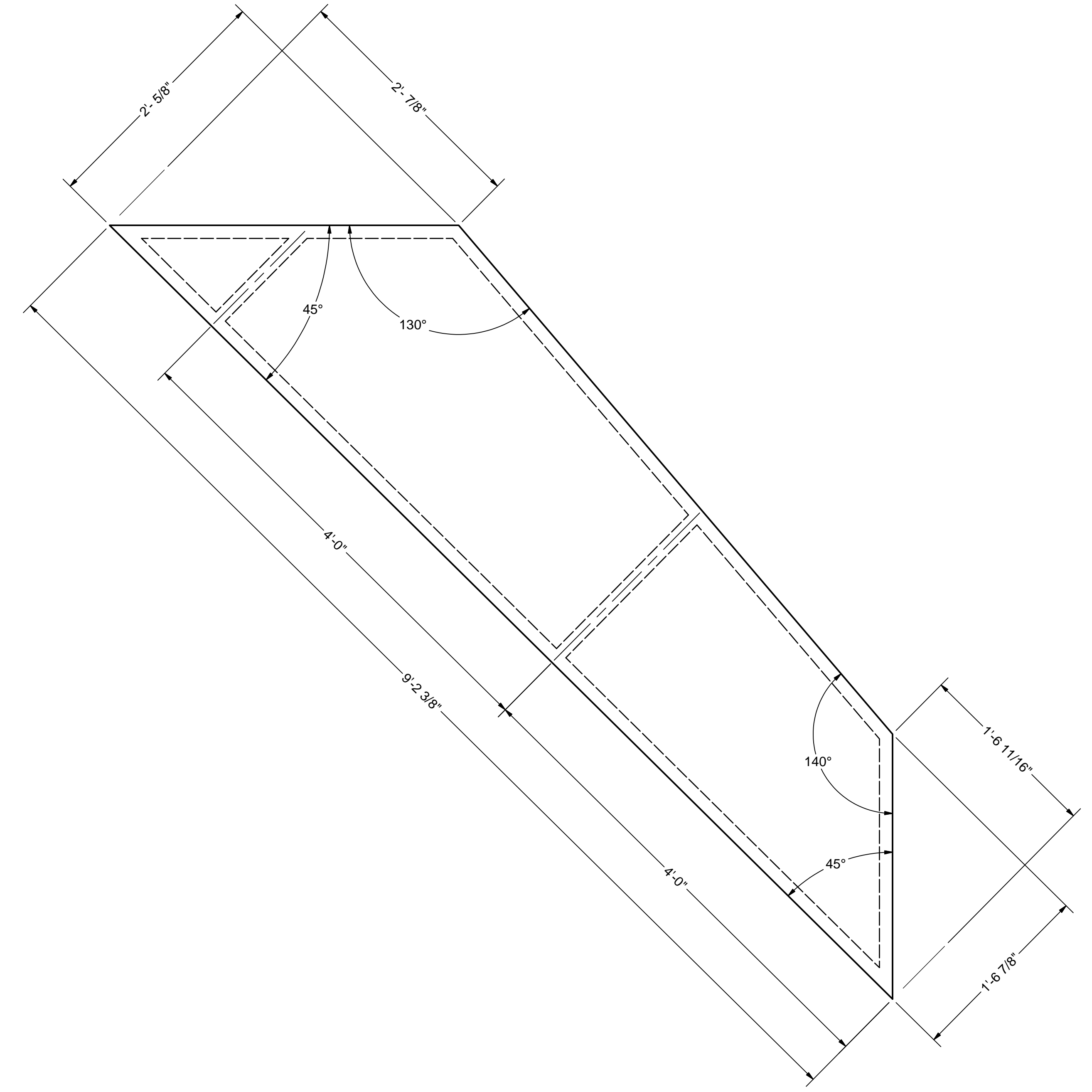

④ **PANEL 4 BEAM 4 SR - DS FACE**
 1-1/2"=1'-0"
 1 AS SHOWN, 1 R&R AS BEAM 4 SL

REFERENCED	
FROM	TO

JOB ID: _____
 DRAWN BY: **Ken Sly**
 APPROVED BY: _____
 ORIGINAL DATE: **1/19/2012**
 DUE DATE: _____
 SCALE: **1-1/2"=1'-0"**

A1-P15
 LATEST REVISION: **2/6/2012** **B**

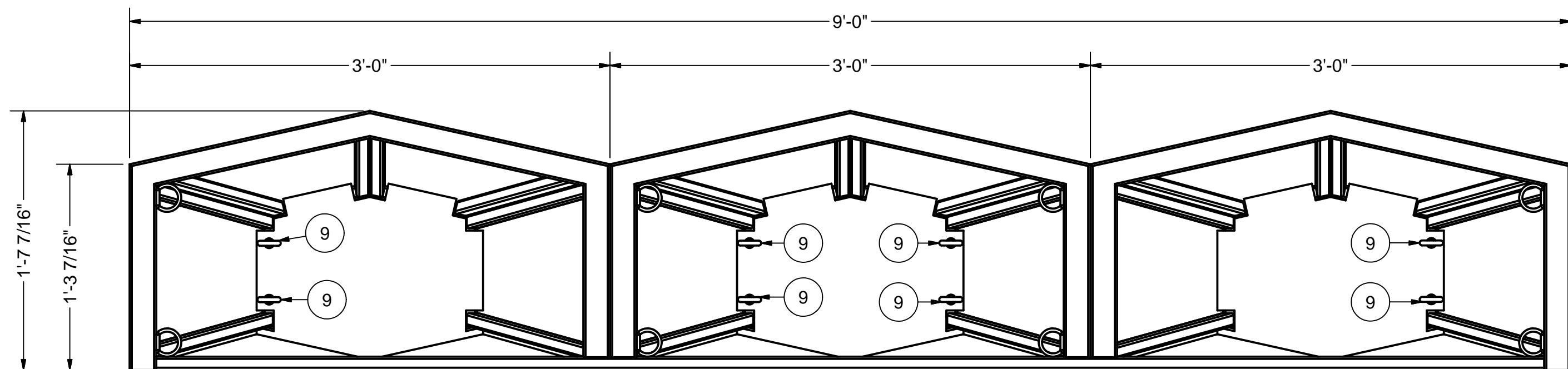

1 BIKE ASSM - PLAN
 1-1/2"=1'-0"
 1 REQUIRED

NOTES:
 FLYING FRAME IS STEEL TUBE AND THE COVERING AND WHEELS ARE WOOD CONSTRUCTION. 12VDC 12RPM MOTORS OPERATE EACH WHEEL. A SHELF ABOVE THE WHEEL IS PROVIDED FOR BATTERY LOCATION AND ACCESS TO EYEBOLT NUTS UNDER PLATFORM.

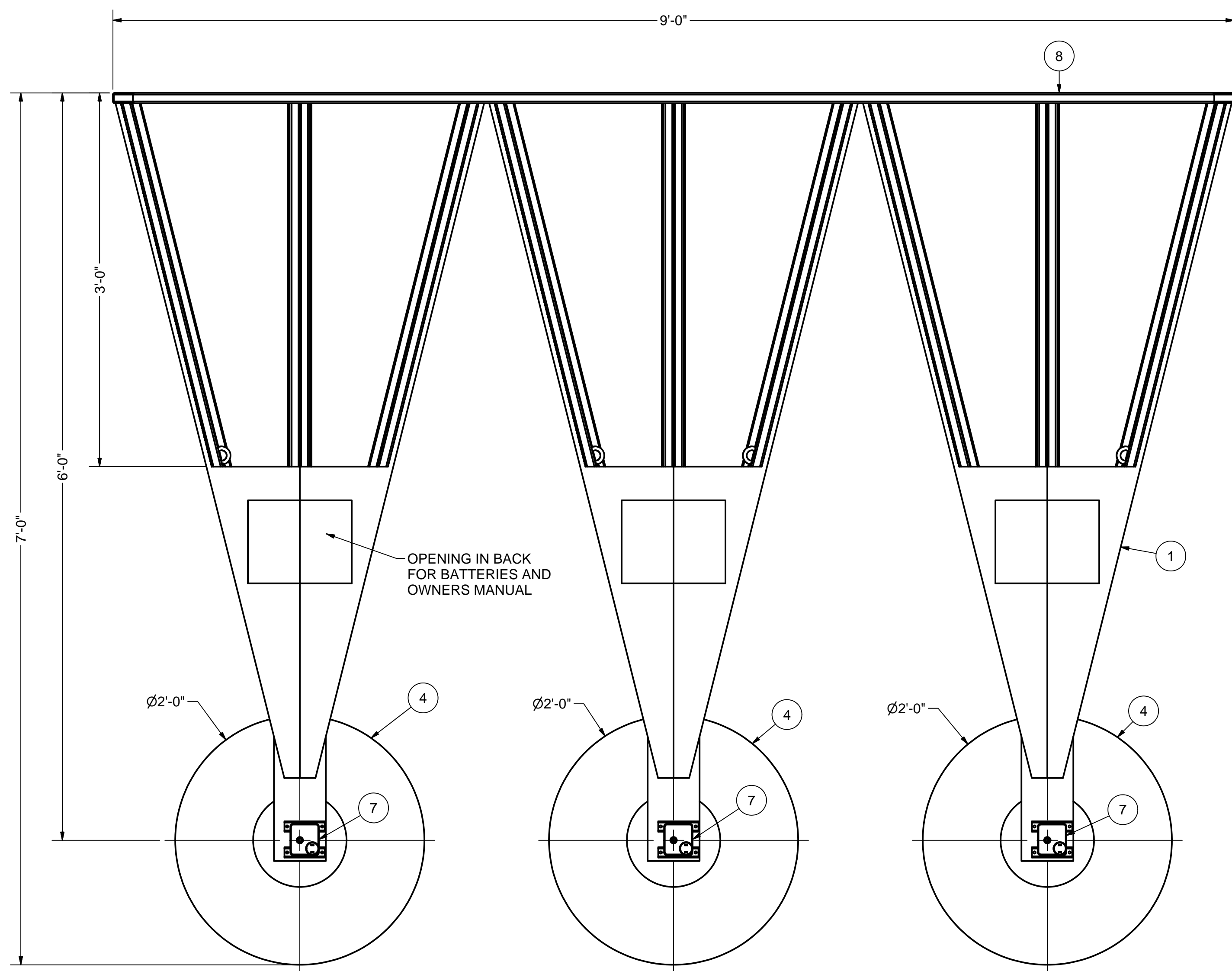

2 BIKE ASSM - US ELEV
 1-1/2"=1'-0"
 1 REQUIRED

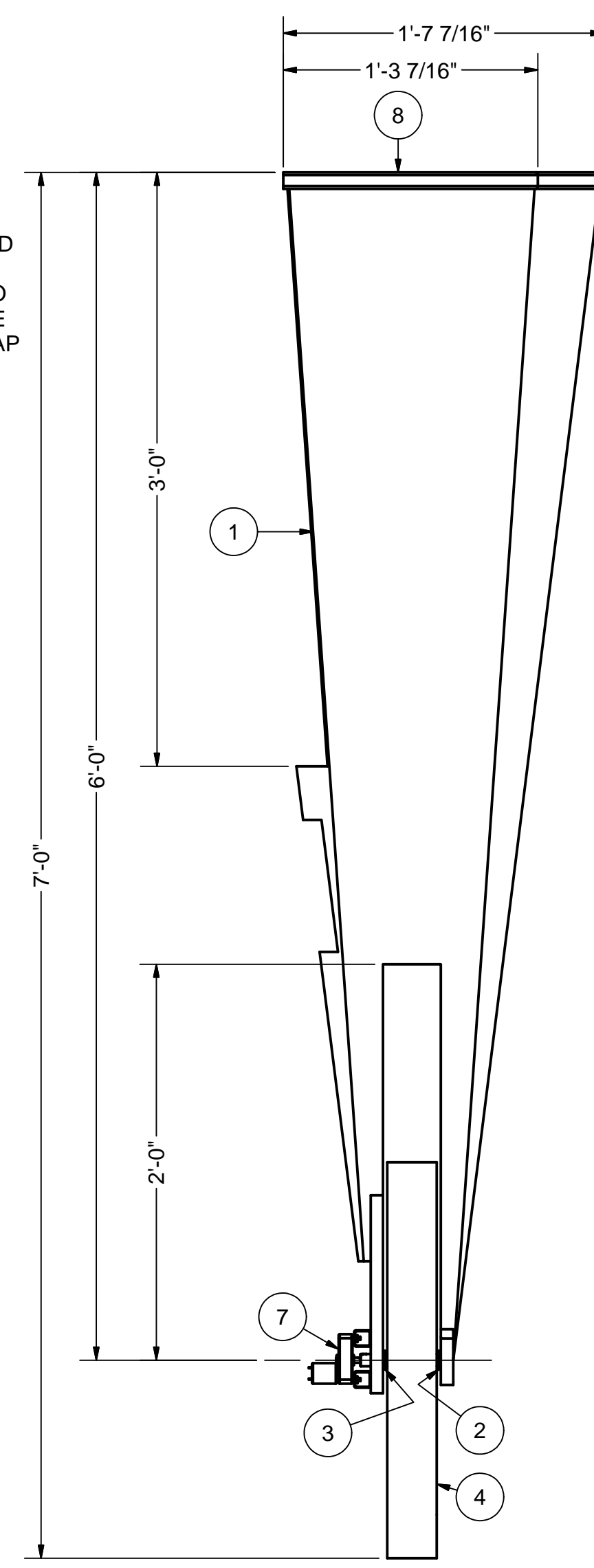

3 BIKE ASSM -SR ELEV
 1-1/2"=1'-0"
 1 REQUIRED

D-RINGS, CHAINS, AND DOG CLIPS MAY ALSO BE REQUIRED ON US SIDE OF BIKE FRAME TO KEEP SINGERS SAFE INSIDE.

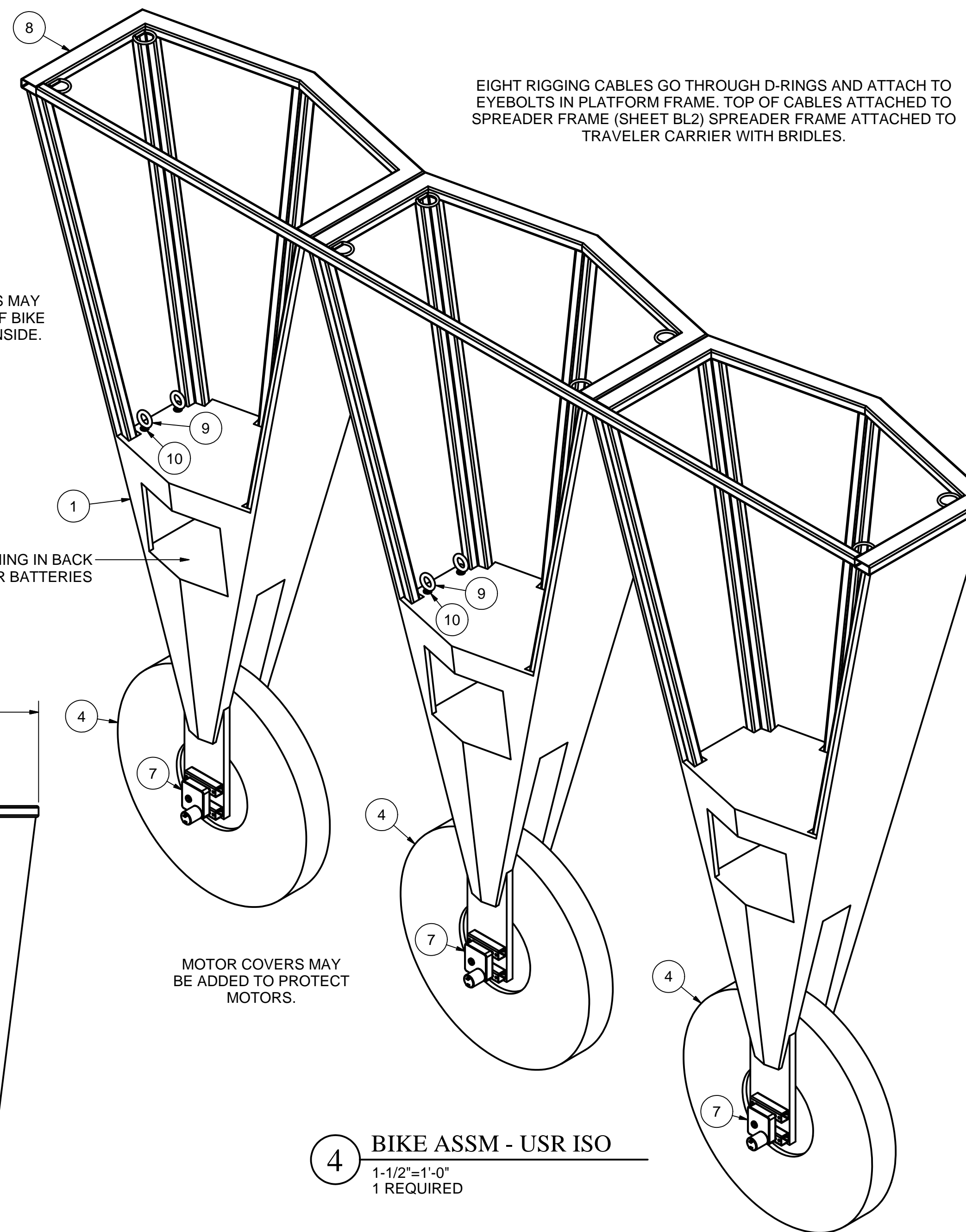

4 BIKE ASSM - USR ISO
 1-1/2"=1'-0"
 1 REQUIRED

BUILD STEEL FLYING FRAME FIRST THEN FIT THE WOOD FACIA TO THE FRAME.

Parts List				
ITEM	QTY	PART NUMBER	STOCK NUMBER	DESCRIPTION
1	1	MF Bike wood MASTER		SHEETS BL5-BL6
2	3	Flange Bushing 75x 5	Mc-Carr 6338K467	SAE 841 Bronze Flanged-Sleeve Bearing for 3/4" Shaft Dia, 7/8" OD, 1/2" L, 1-1/4" Flange OD
3	3	Flange Bushing 75x 75	Mc-Carr 6338K472	SAE 841 Bronze Flanged-Sleeve Bearing for 3/4" Shaft Dia, 7/8" OD, 3/4" L, 1-1/8" Flange OD
4	3	MF Bike Wheel assm		SHEET BL7
5	3	MF Bike axle		SHEET BL8 VIEWS 7-8
6	3	ANSI B18.3 - 1/4-28 UNF x 0.25	McM-C 91375A556	Alloy Steel Cup Point Socket Set Screw 1/4"-28 Thread, 1/4" Length (PACK OF 100)
7	3	MF Motor Mounted Frame assm		SHEET BL8 VIEWS 1-3
8	1	MF Bike Struct		SHEETS BL3-BL4
9	8	eyebolt forged 375-16x2_5	McM-C 3014T62	Steel Eyebolt with Shoulder for Lifting 3/8"-16 Thread, 1400# WtL, 2-1/2" Thread Length
10	16	ANSI B18.22.1 - 3/8 - narrow - Type B		Plain Washer (Inch)Type A and B
11	8	ANSI B18.2.2 - 3/8 - 16		Hex Nuts (Inch Series) Hex Nut

REFERENCED	
FROM	TO

JOB ID:
 DRAWN BY: Ken Sly
 APPROVED BY:
 ORIGINAL DATE: 2/27/2012
 DUE DATE:
 SCALE: 1-1/2"=1'-0"
BL1
 LATEST REVISION

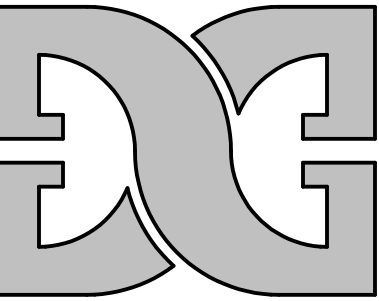

DIMENSIONAL GRAPHICS
 PHONE & FAX (650) 342-5724
 kenny@dimensional.com
 www.dgflow.com
MATERIAL CALLOUTS ARE TO CLARIFY THE DESIGN INTENT. ALL DESIGN CONCEPTS AND MATERIALS MUST BE VERIFIED BY A LICENSED ENGINEER.

FLYING BIKE STRUCTURAL FRAME CONT
SAN FRANCISCO OPERA
MAGIC FLUTE 2012

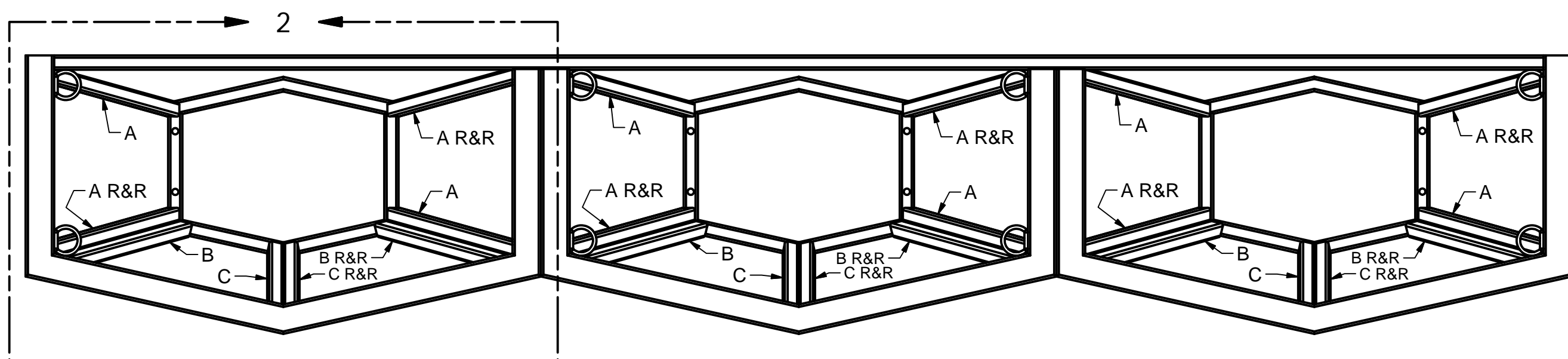

ALL CONNECTING TUBES BETWEEN CAP AND PLATFORM ARE TS 1x1x.083 STEEL.

1 **STRUCT FRAME - PLAN**
 1-1/2"=1'-0"
 1 REQUIRED

TUBE REQUIREMENTS:
 TUBE A: 6 REQUIRED
 TUBE A R&R: 6 REQUIRED
 TUBE B: 3 REQUIRED
 TUBE B R&R: 3 REQUIRED
 TUBE C: 3 REQUIRED
 TUBE C R&R: 3 REQUIRED

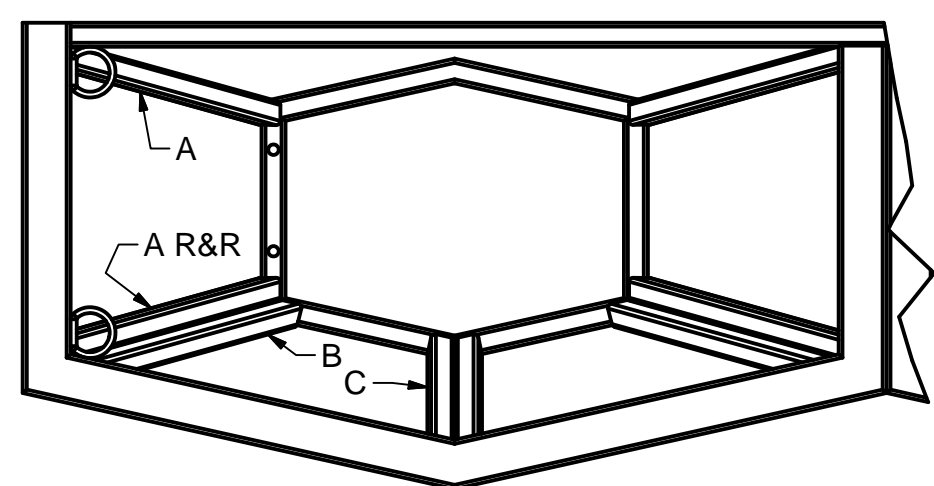

2 **DETAIL**
 1-1/2"=1'-0"

ONLY TUBES A, A R&R, B & C ARE DEVELOPED BEYOND VIEW 2

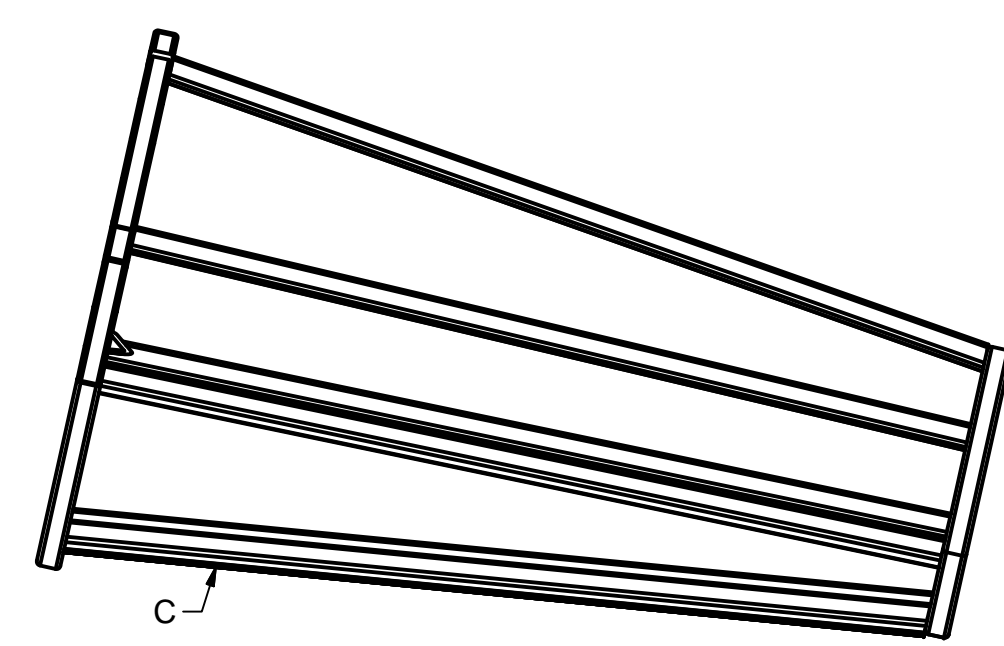

2A **PROJECTION**
 1-1/2"=1'-0"

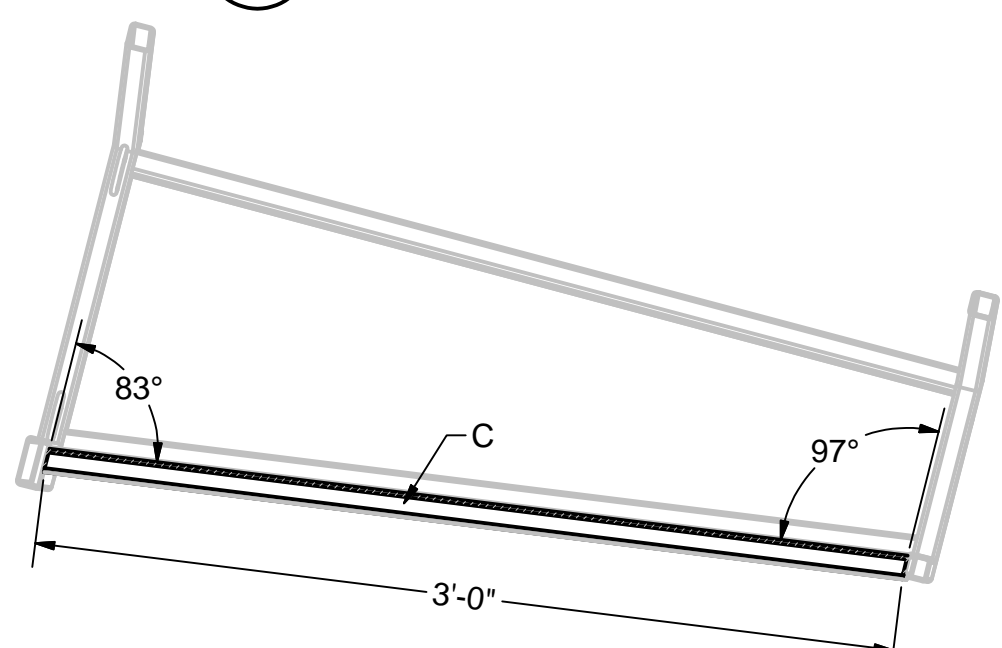

4A **CENTER SIDE - TRUE VIEW**
 1-1/2"=1'-0"

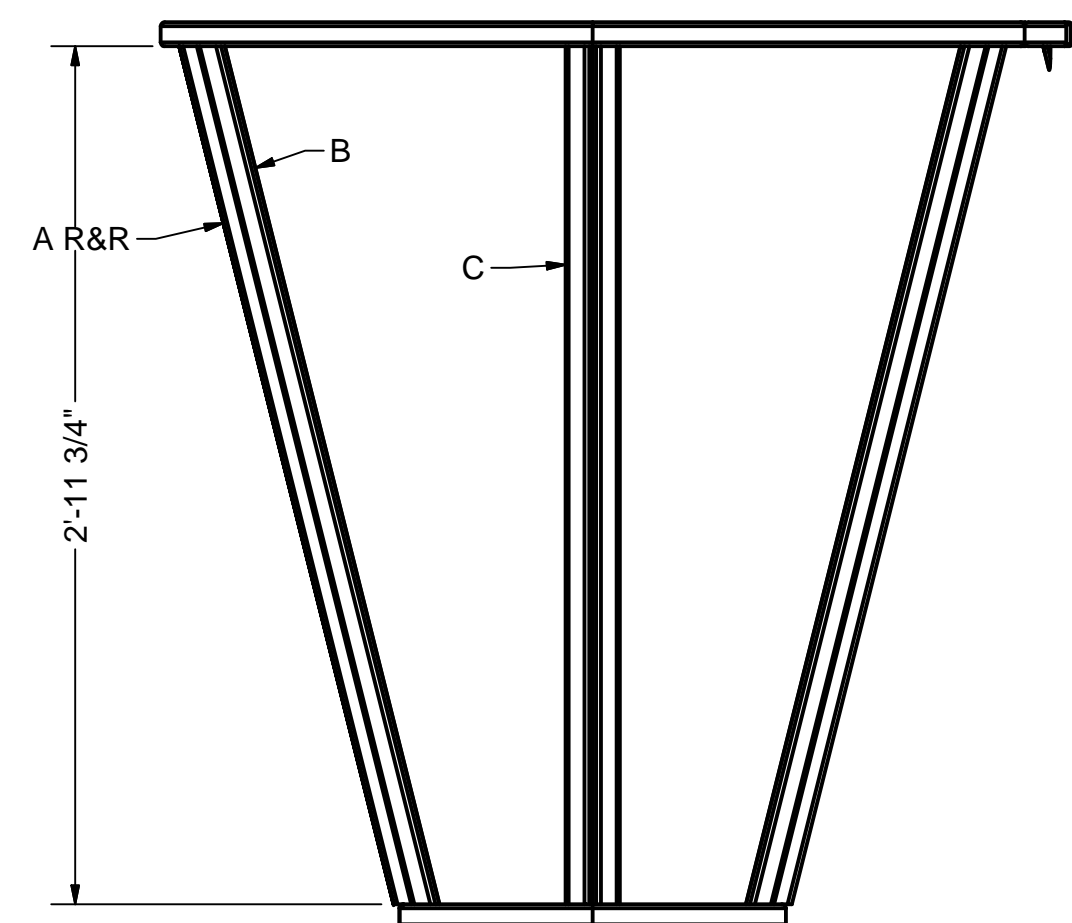

2B **PROJECTION**
 1-1/2"=1'-0"

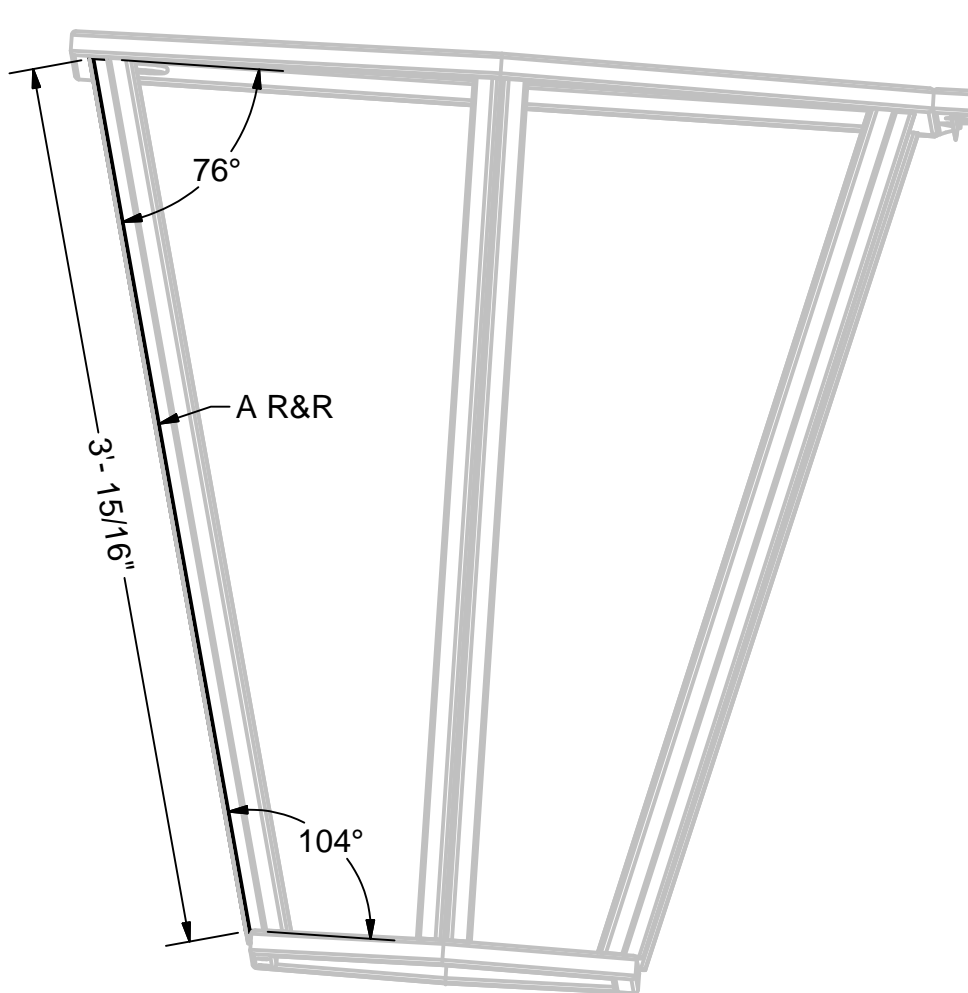

3B **DS CORNER - TRUE VIEW**
 1-1/2"=1'-0"

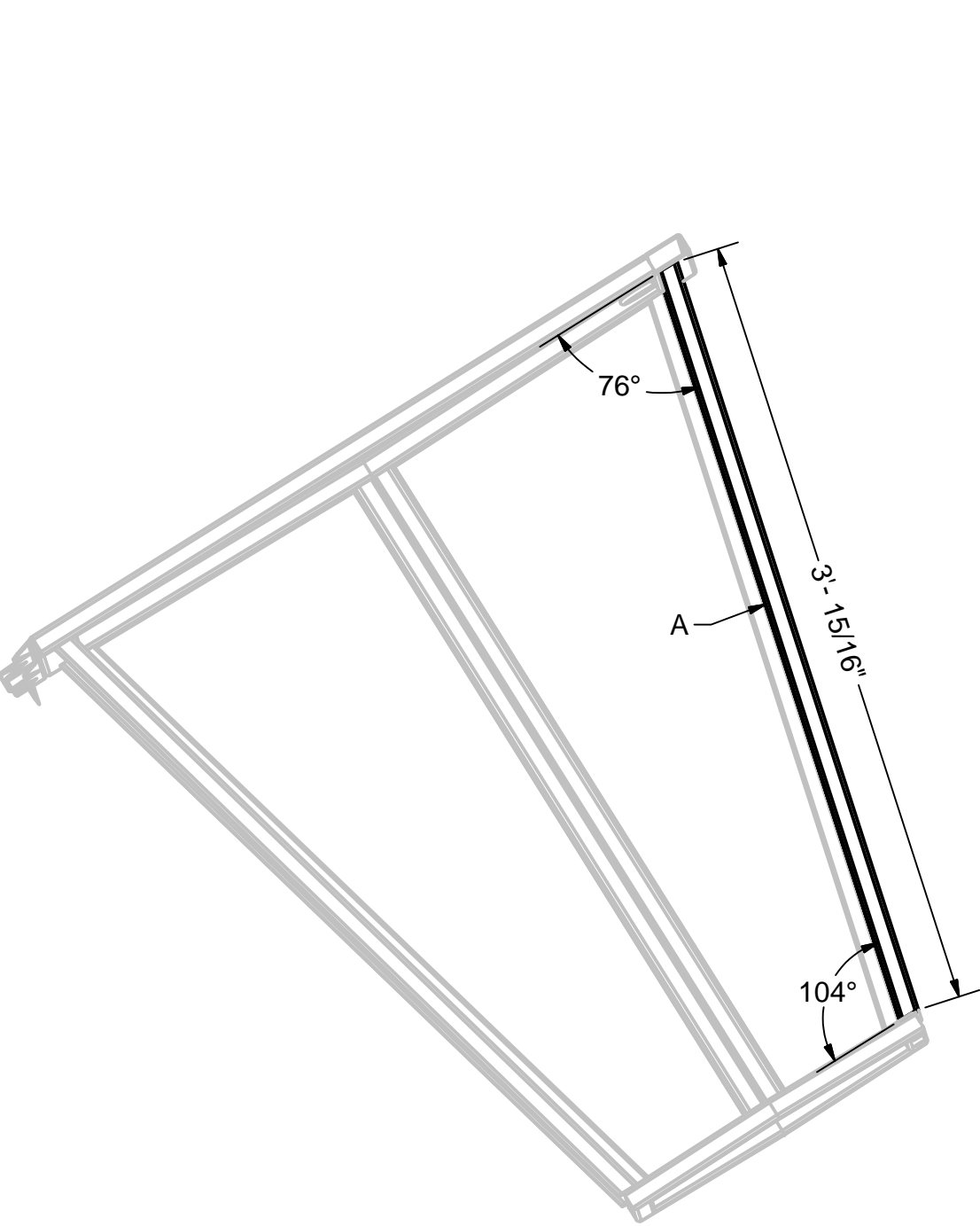

3A **US CORNER - TRUE VIEW**
 1-1/2"=1'-0"

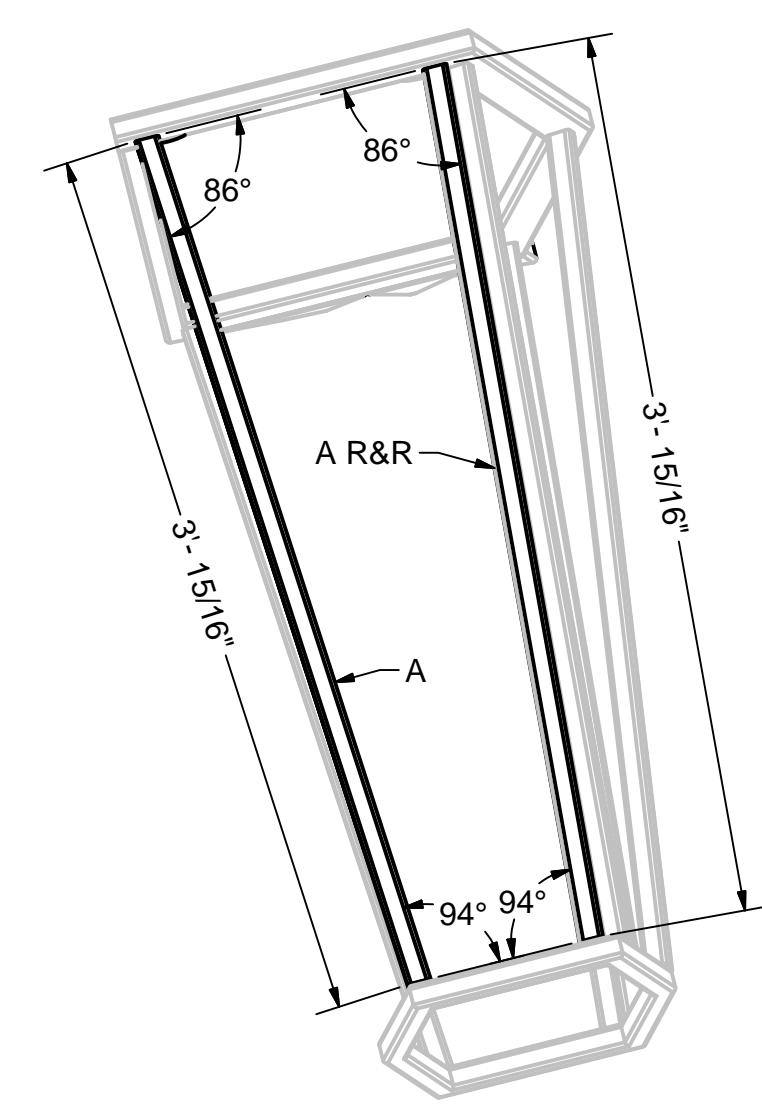

3 **SIDE - TRUE VIEW**
 1-1/2"=1'-0"

ALL CONNECTING TUBES BETWEEN CAP AND PLATFORM ARE TS 1x1x.083 STEEL.

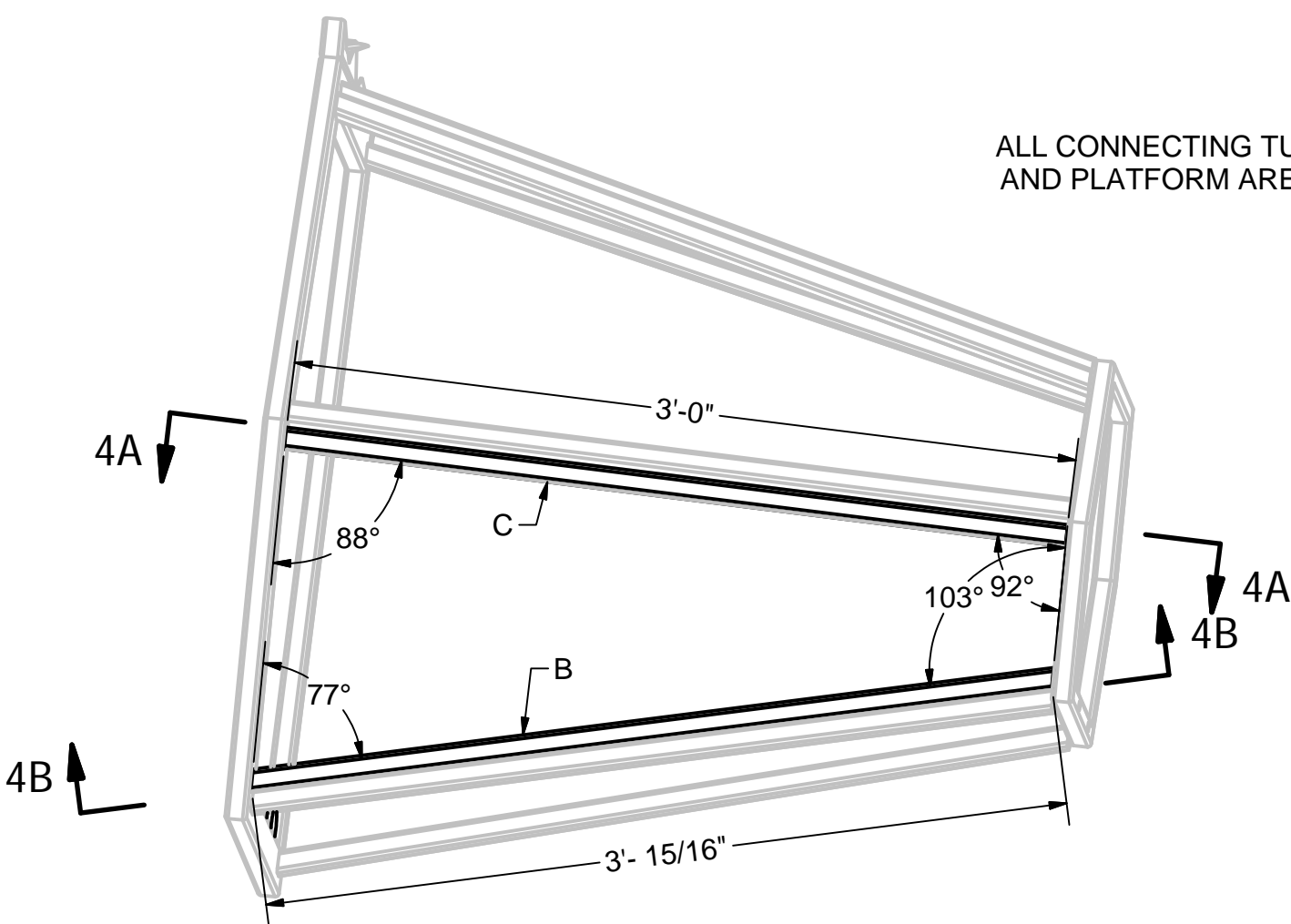

4 **FACE - TRUE VIEW**
 1-1/2"=1'-0"

ALL CONNECTING TUBES BETWEEN CAP AND PLATFORM ARE TS 1x1x.083 STEEL.

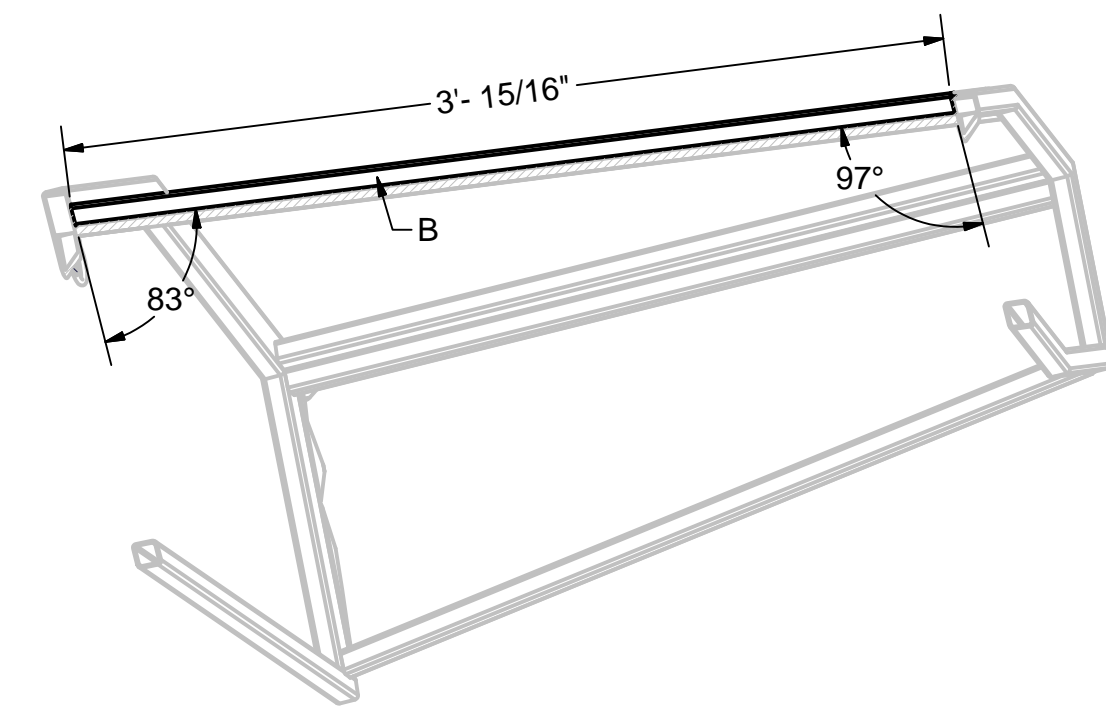

4B **FACE CORNER - TRUE VIEW**
 1-1/2"=1'-0"

REFERENCED	
FROM	TO

JOB ID: _____
 DRAWN BY: **Ken Sly**
 APPROVED BY: _____
 ORIGINAL DATE: **2/27/2012**
 DUE DATE: _____
 SCALE: **1-1/2"=1'-0"**
BL4
 LATEST REVISION **A**

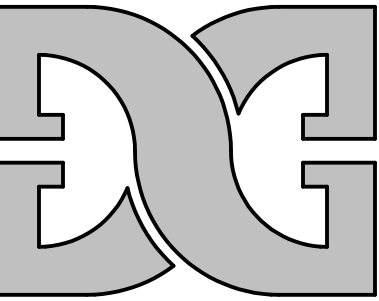

DIMENSIONAL GRAPHICS
 PHONE & FAX (650) 342-5724
 kenny@dgflow.com
 www.dgflow.com
 MATERIAL CALLOUTS ARE TO CLARIFY THE DESIGN INTENT. ALL DESIGN CONCEPTS AND MATERIALS MUST BE VERIFIED BY A LICENSED ENGINEER.

FLYING BIKE WOOD COVERING
SAN FRANCISCO OPERA
MAGIC FLUTE 2012

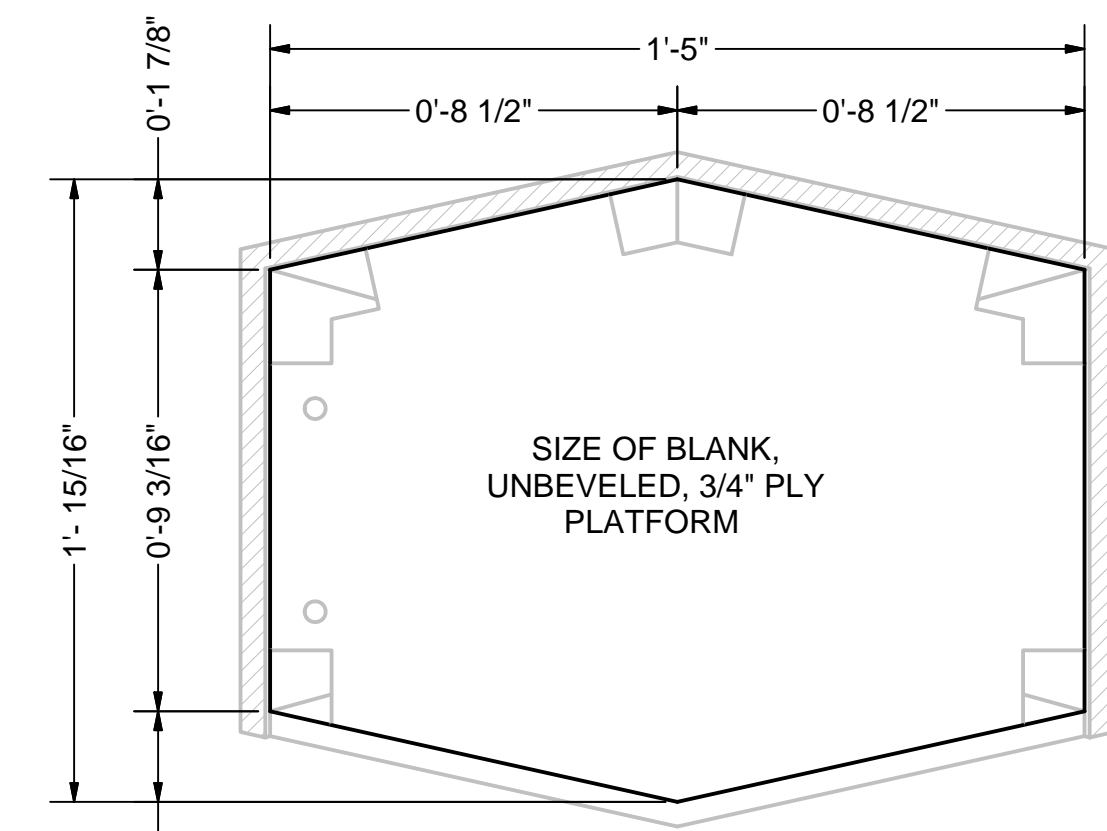

A PLATFORM BLANK
 3"=1'-0"
 3 REQUIRED

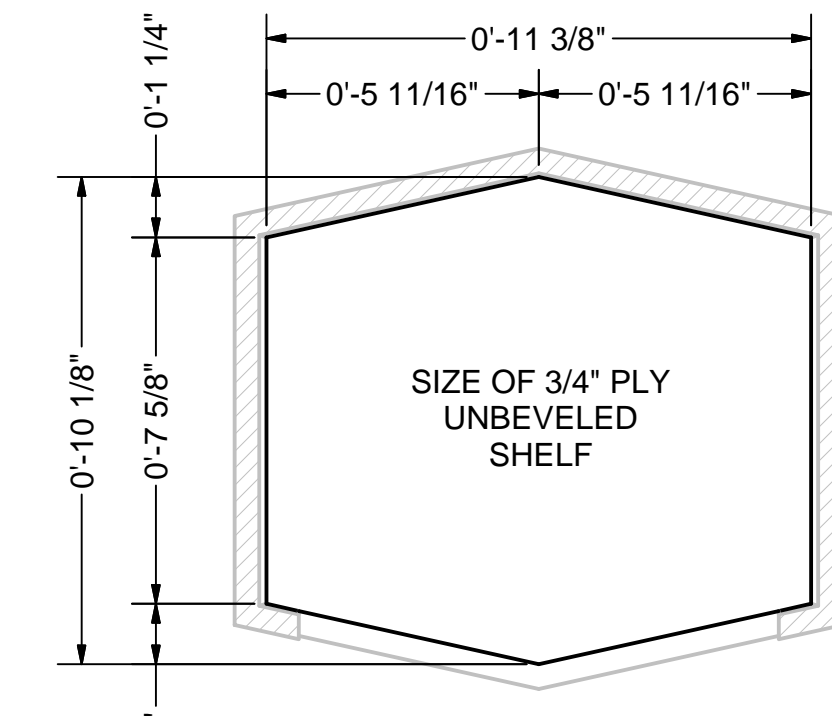

B SHELF
 3"=1'-0"
 3 REQUIRED

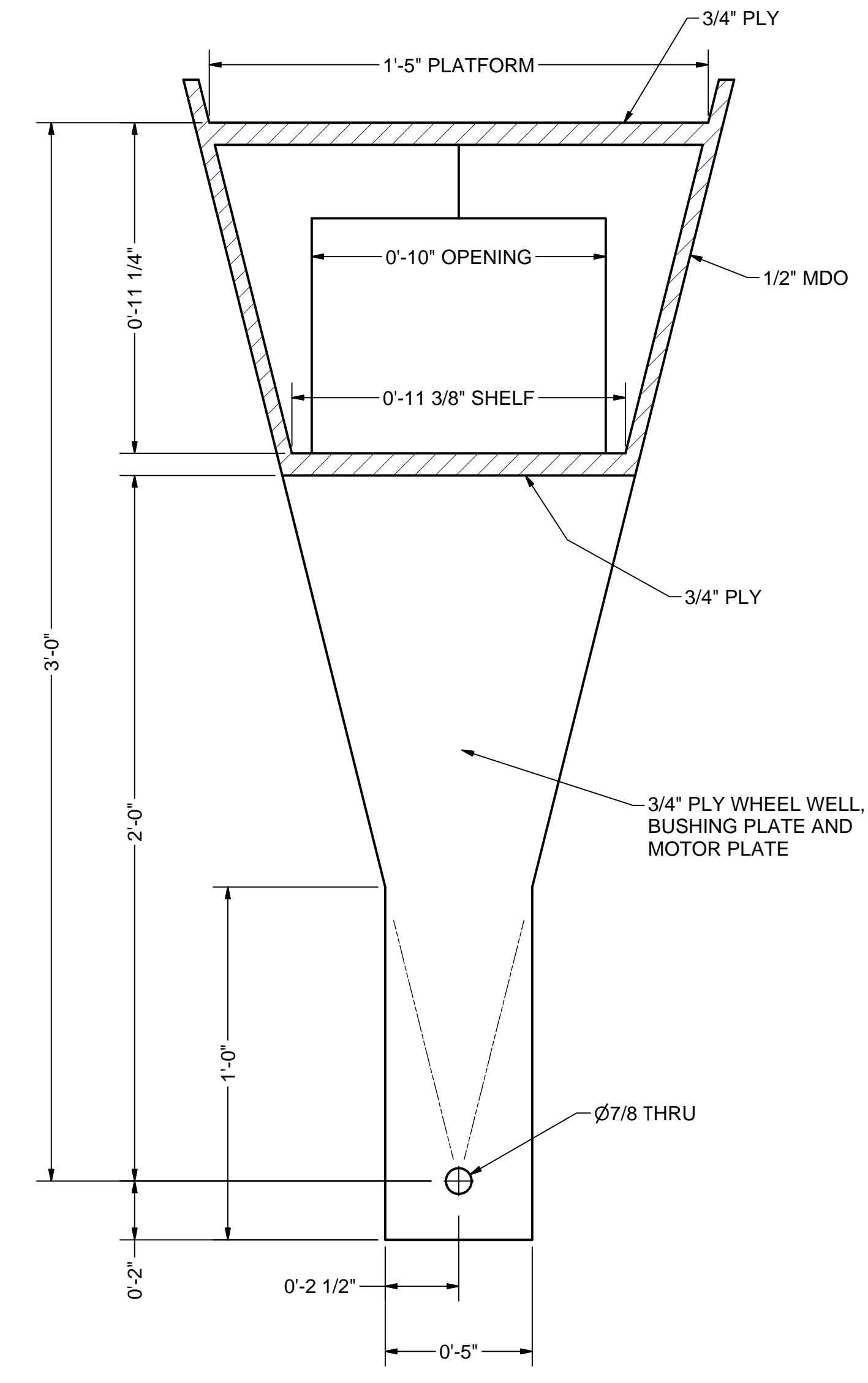

1 SECTION LOOKING US
 3"=1'-0"
 TYPICAL 3 PLACES

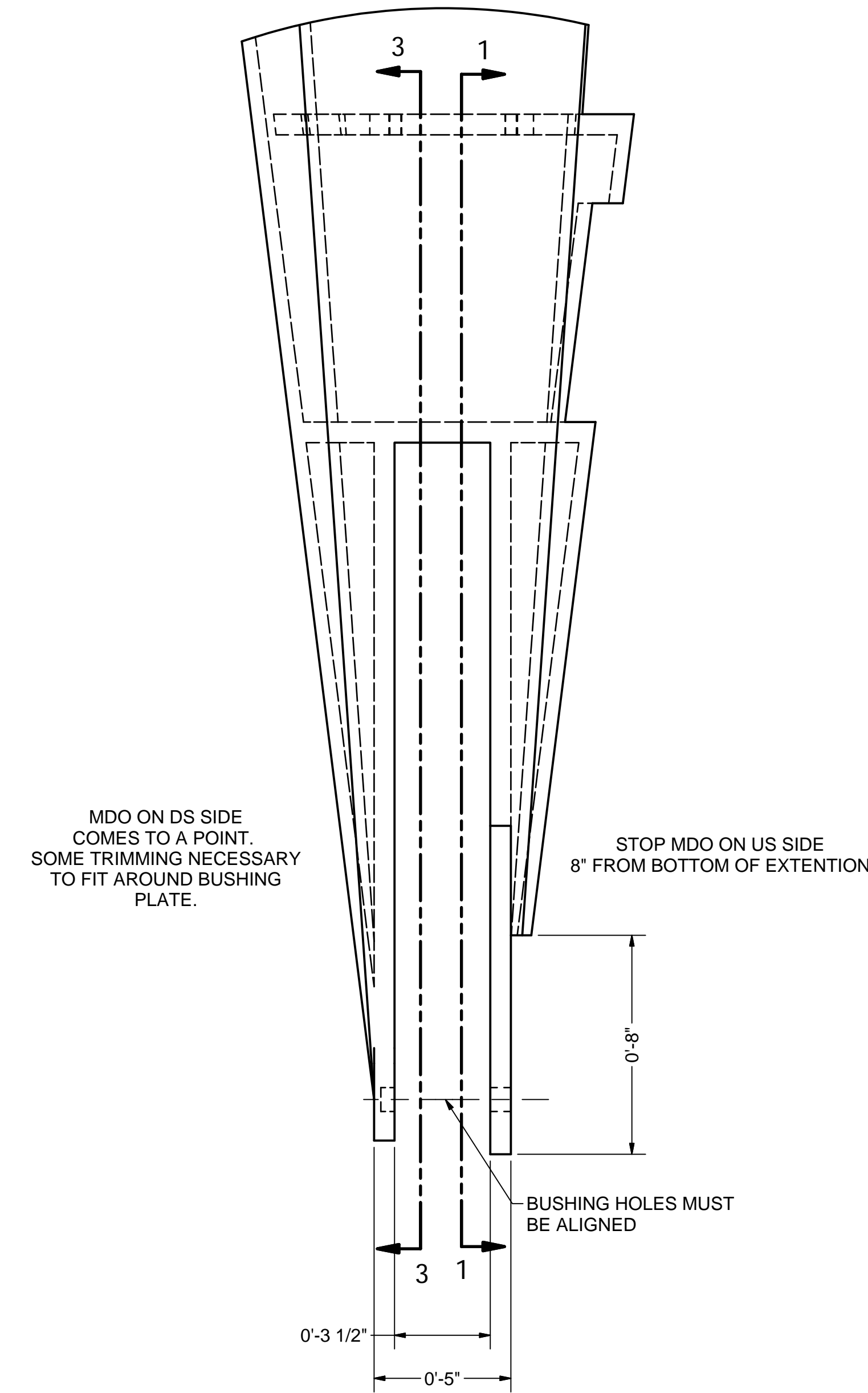

2 BIKE WHEEL WELL - SIDE
 3"=1'-0"
 TYPICAL 3 PLACES

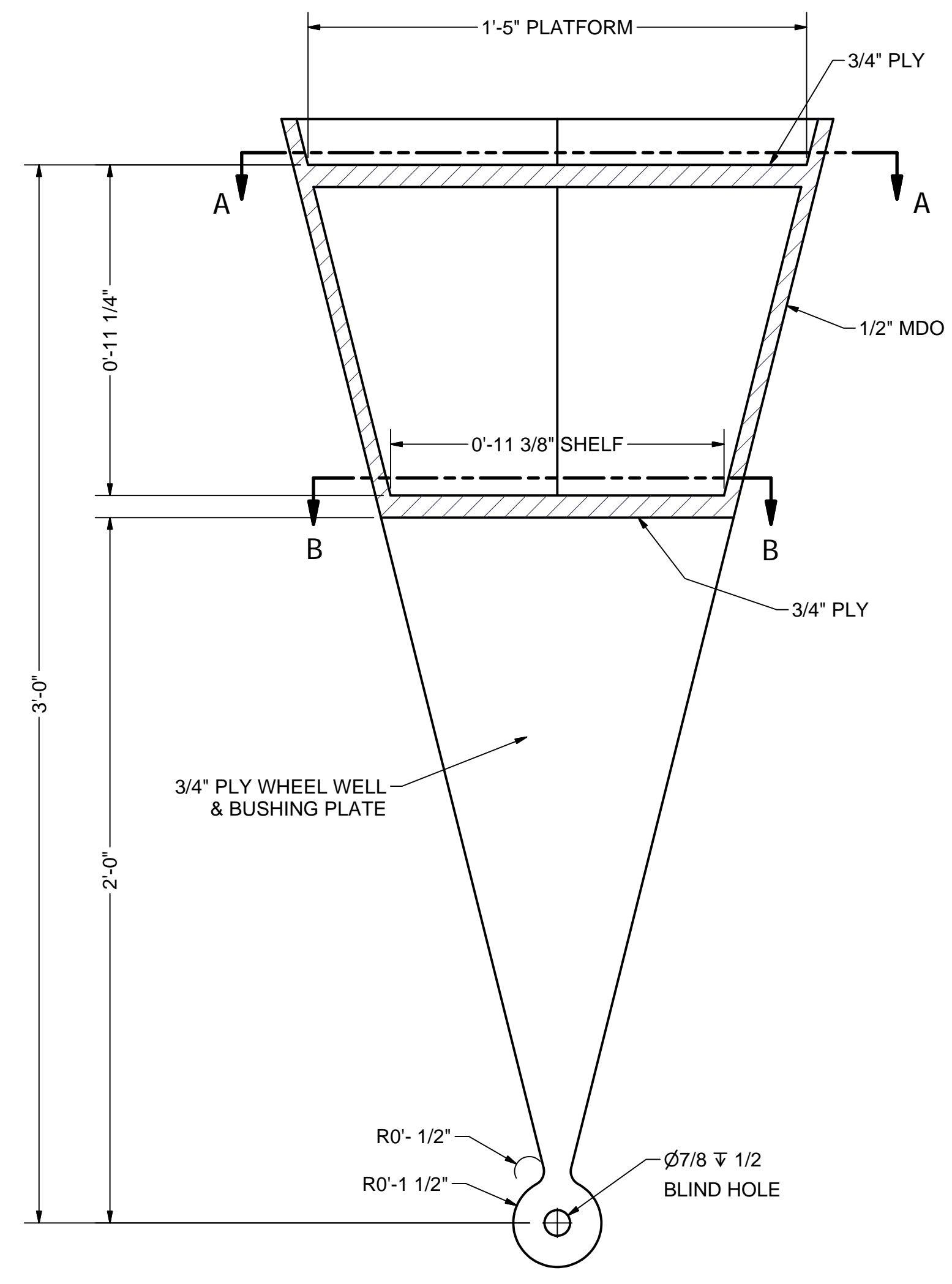

3 SECTION LOOKING DS
 3"=1'-0"
 TYPICAL 3 PLACES

REFERENCED	
FROM	TO

JOB ID: _____
 DRAWN BY: **Ken Sly**
 APPROVED BY: _____
 ORIGINAL DATE: **2/28/2012**
 DUE DATE: _____
 SCALE: **3"=1'-0"**

BL6
 LATEST REVISION

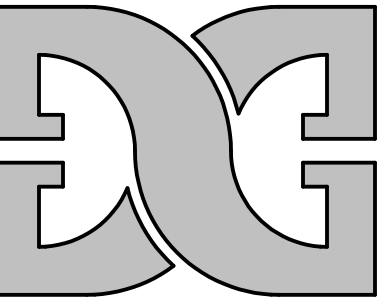

DIMENSIONAL GRAPHICS
 PHONE & FAX (650) 342-5724
 kensly@dimensionalgraphics.com
 www.dgflow.com
MATERIAL CALLOUTS ARE TO CLARIFY THE DESIGN INTENT. ALL DESIGN CONCEPTS AND MATERIALS MUST BE VERIFIED BY A LICENSED ENGINEER.

Parts List				
ITEM	QTY	PART NUMBER	STOCK NUMBER	DESCRIPTION
1	1	MF Bike Wheel		SHEET BL7 VIEW 1-2
2	1	Shaft Collar .75 Fce Mnt	Mc-Carr 9677T1	Face-Mount One-Piece Shaft Collars 3/4" Bore, 1-1/2" Outside Diameter, .49" Width

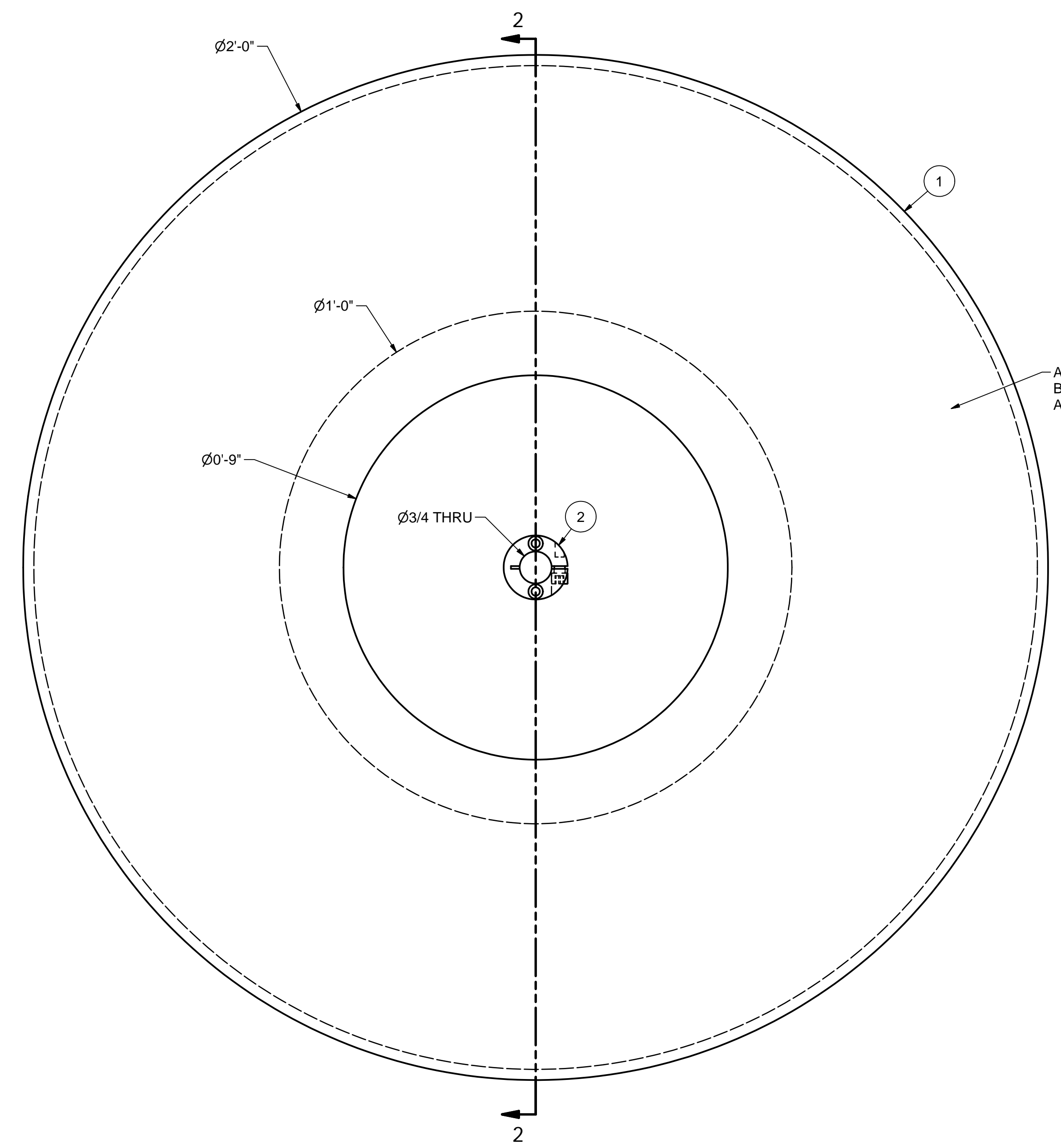

1 WHEEL - US ELEV
 HALF SIZE
 3 REQUIRED

ADD BLOCKING AS NEEDED BUT KEEP EVERYTHING SYMETRICAL AND BALANCED. THIS WHEEL ROTATES.

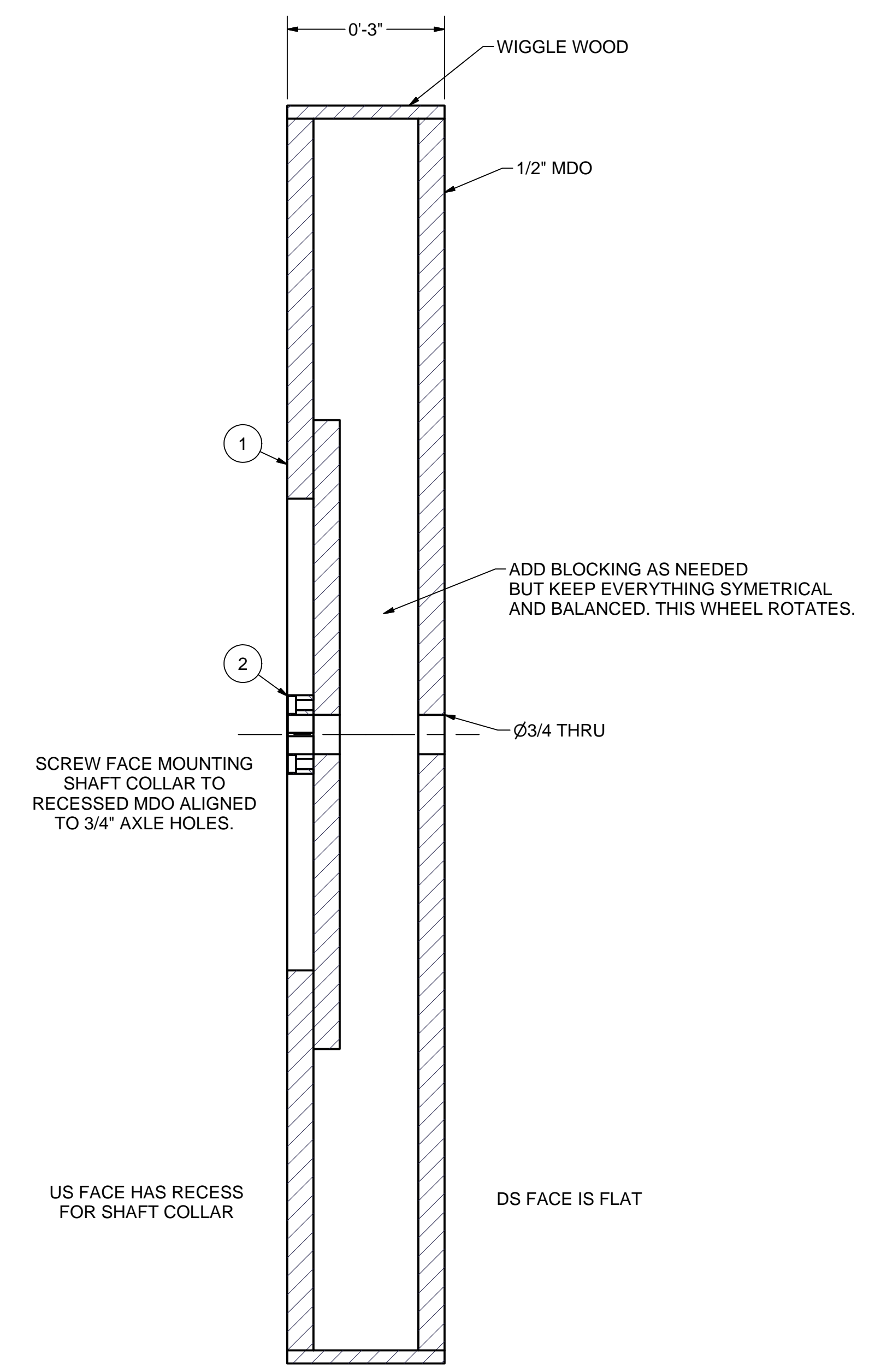

2 SECTION
 HALF SIZE

FLYING BIKE WHEEL ASSEMBLY
 SAN FRANCISCO OPERA
 MAGIC FLUTE 2012

REFERENCED	
FROM	TO

JOB ID: _____
 DRAWN BY: Ken Sly
 APPROVED BY: _____
 ORIGINAL DATE: 2/28/2012
 DUE DATE: _____
 SCALE: HALF SIZE

BL7
 LATEST REVISION

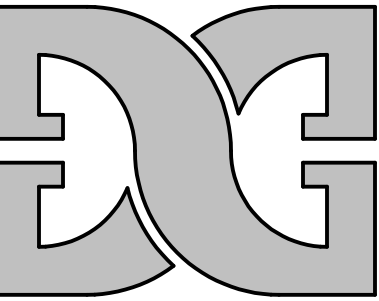

DIMENSIONAL GRAPHICS
 PHONE & FAX (650) 342-5724
 kenny@diglow.com
 www.diglow.com
 MATERIAL CALLOUTS ARE TO CLARIFY THE DESIGN INTENT. ALL DESIGN CONCERNS AND MATERIALS MUST BE VERIFIED BY A LICENSED ENGINEER.

3 ASSEMBLIES REQUIRED. MULTIPLY QUANTITY BY 3.

Parts List				
ITEM	QTY	PART NUMBER	STOCK NUMBER	DESCRIPTION
1	1	Motor Grainger 2L008	Grainger 2L008	Dayton 12 VDC, 12 RPM Gearmotor
2	2	MF Bike Motor Mount		SHEET BL8 VIEWS 4-6
3	4	ANSI B18.6.3 - 10 - 24		Hex Machine Screw Nut

DEPENDING ON NOISE DAMPING AND/OR PROTECTION, A BOX OR FRAME MAY NEED TO BE BUILT AROUND THE MOTOR ASSEMBLY.

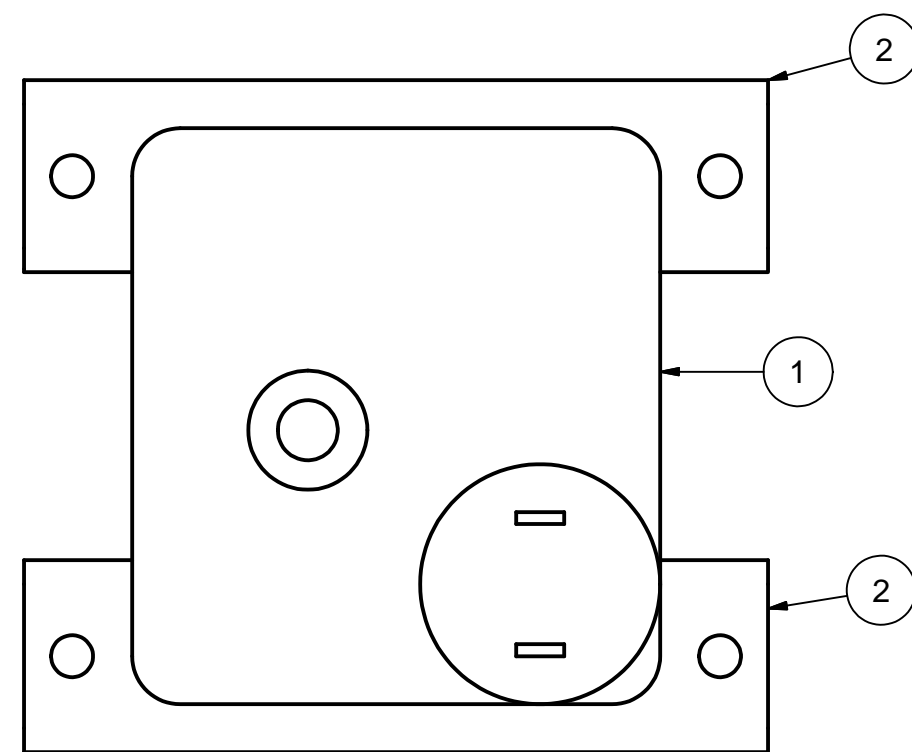

1 MOTOR ASSM - US ELEV
 FULL SIZE
 3 ASSEMBLIES REQUIRED

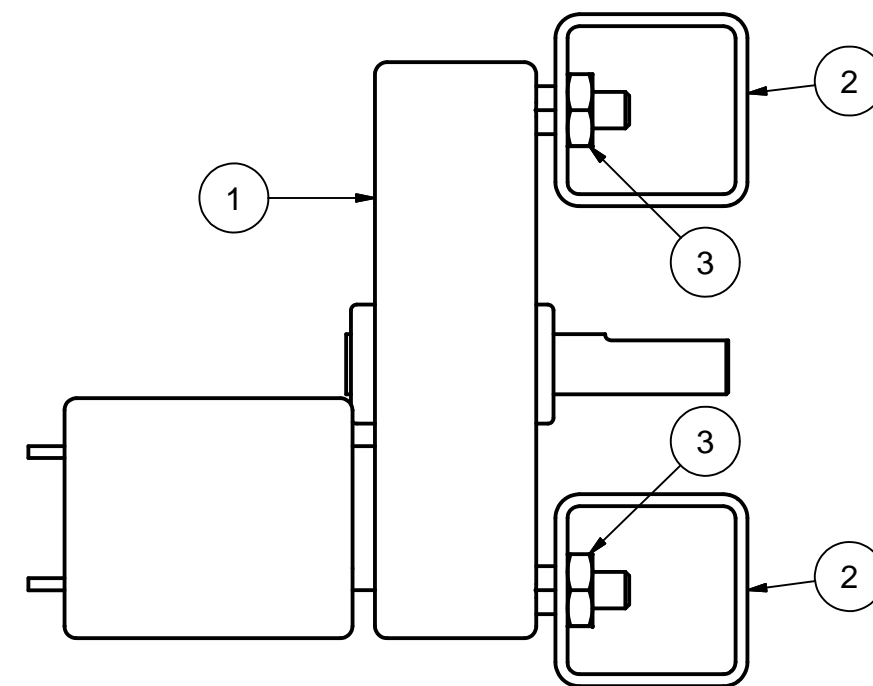

2 MOTOR ASSM - SIDE
 FULL SIZE
 3 ASSEMBLIES REQUIRED

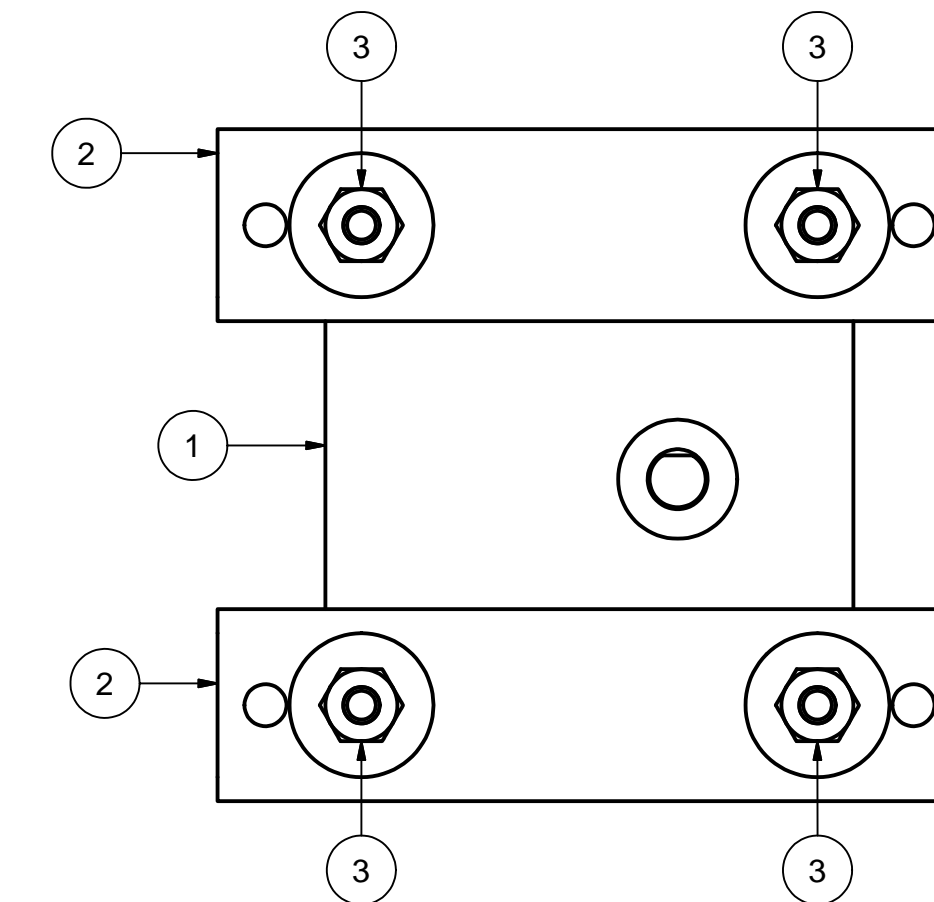

3 MOTOR ASSM - DS ELEV
 FULL SIZE
 3 ASSEMBLIES REQUIRED

WITH MOTOR SHAFT FLAT SPOT FACING TO SIDE THE AXLE SET SCREW CAN BE TIGHTENED.

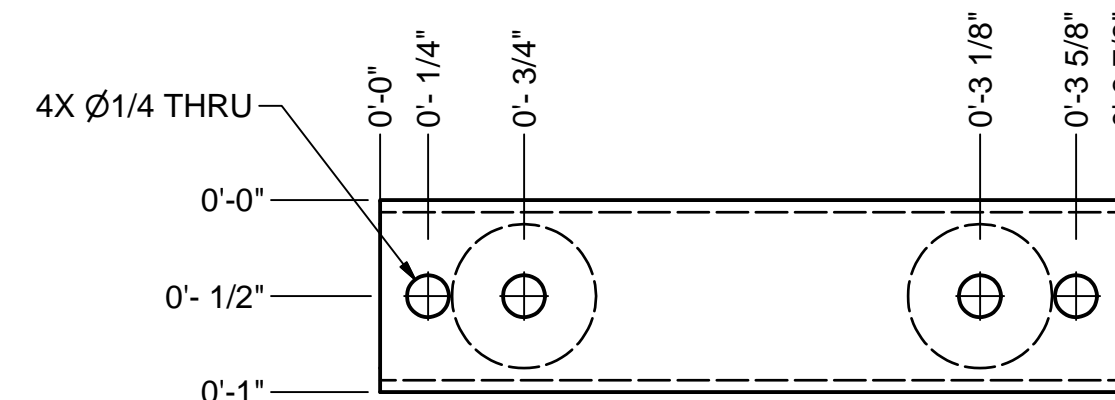

4 MOTOR MOUNT - US ELEV
 FULL SIZE
 6 REQUIRED

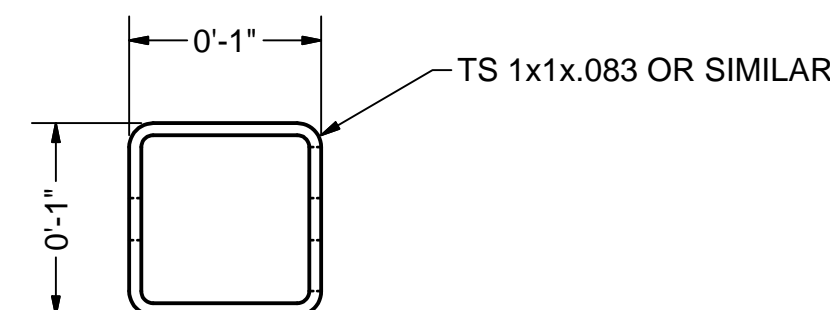

5 MOTOR MOUNT - SIDE
 FULL SIZE
 6 REQUIRED

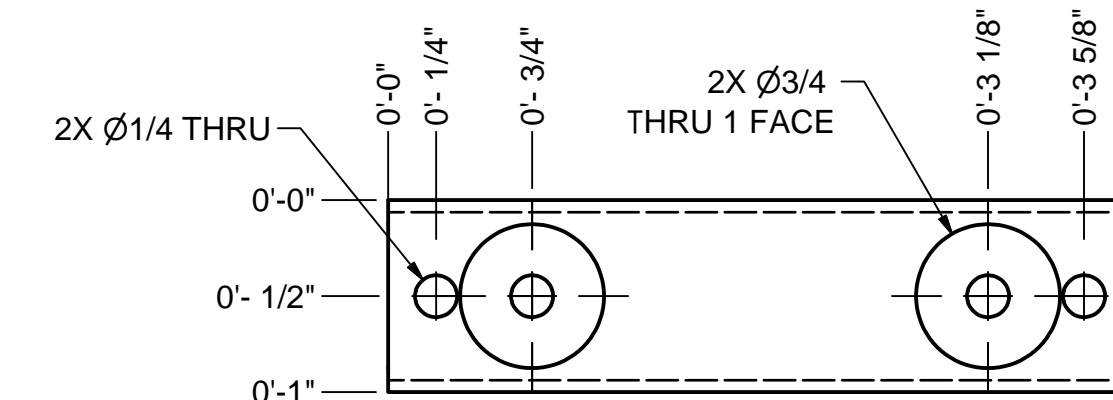

6 MOTOR MOUNT - DS ELEV
 FULL SIZE
 6 REQUIRED

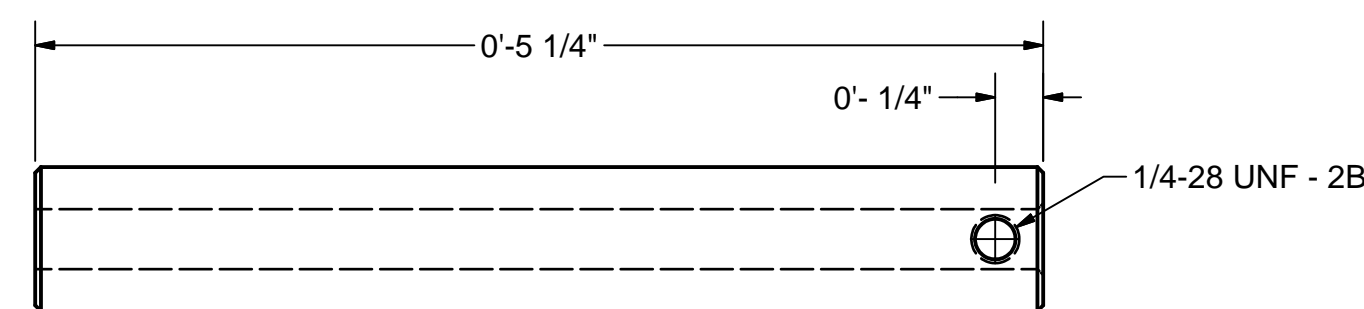

EITHER USE 3/4" OD x 5/16" ID TUBE OR 3/4" ROUND BAR WITH 5/16" CONCENTRIC HOLE 1" DEEP FROM ONE END.

7 BIKE AXLE - PLAN
 FULL SIZE
 3 REQUIRED

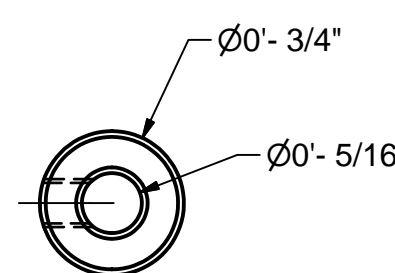

FOR EASE OF CONSTRUCTION THREADED HOLE CAN GO ALL THE WAY THROUGH

8 BIKE AXLE - END
 FULL SIZE
 3 REQUIRED

ALSO REQUIRED (LISTED ON PARTS LIST SHEET BL1)
 Alloy Steel Cup Point Socket Set Screw 1/4"-28 Thread, 1/4" Length

FLYING BIKE MECHANICAL
 SAN FRANCISCO OPERA
 MAGIC FLUTE 2012

REFERENCED	
FROM	TO

JOB ID: _____
 DRAWN BY: Ken Sly
 APPROVED BY: _____
 ORIGINAL DATE: 2/28/2012
 DUE DATE: _____
 SCALE: FULL SIZE
 BL8
 LATEST REVISION A

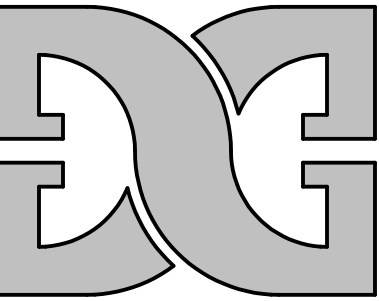

DIMENSIONAL GRAPHICS
 PHONE & FAX (650) 342-5724
 kensly@dimensionalgraphics.com
 www.dgflow.com
MATERIAL CALLOUTS ARE TO CLARIFY THE DESIGN INTENT. ALL DESIGN CONCEPTS AND MATERIALS MUST BE VERIFIED BY A LICENSED ENGINEER.

DECK LAYOUT
SAN FRANCISCO OPERA
MAGIC FLUTE 2012

Parts List			
ITEM	QTY	PART NUMBER	DESCRIPTION
1	9	MF Raker Pier DS Track DS	SHEET DK2 VIEWS 1-2
2	9	MF Raker Pier DS Track US	SHEET DK2 VIEWS 1-2
3	9	MF Raker Pier US Track DS	SHEET DK2 VIEWS 1-2
4	9	MF Raker Pier US Track US	SHEET DK2 VIEWS 1-2
5	1	MF Raked Stage deck	SHEET DK4
6	4	MF Track Pony Wall DS	SHEET DK3 VIEWS 1-2
7	4	MF Track Pony Wall US	SHEET DK3 VIEWS 3-4
8	8	English Track 16ft	STANDARD TRACK 2 LENGTHS @ 64' EACH
9	9	MF Track DS Pony DS Hog	SHEET DK2 VIEWS 1-2
10	9	MF Track DS Pony US Hog	SHEET DK2 VIEWS 1-2
11	9	MF Track US Pony DS Hog	SHEET DK2 VIEWS 1-2
12	9	MF Track US Pony US Hog	SHEET DK2 VIEWS 1-2

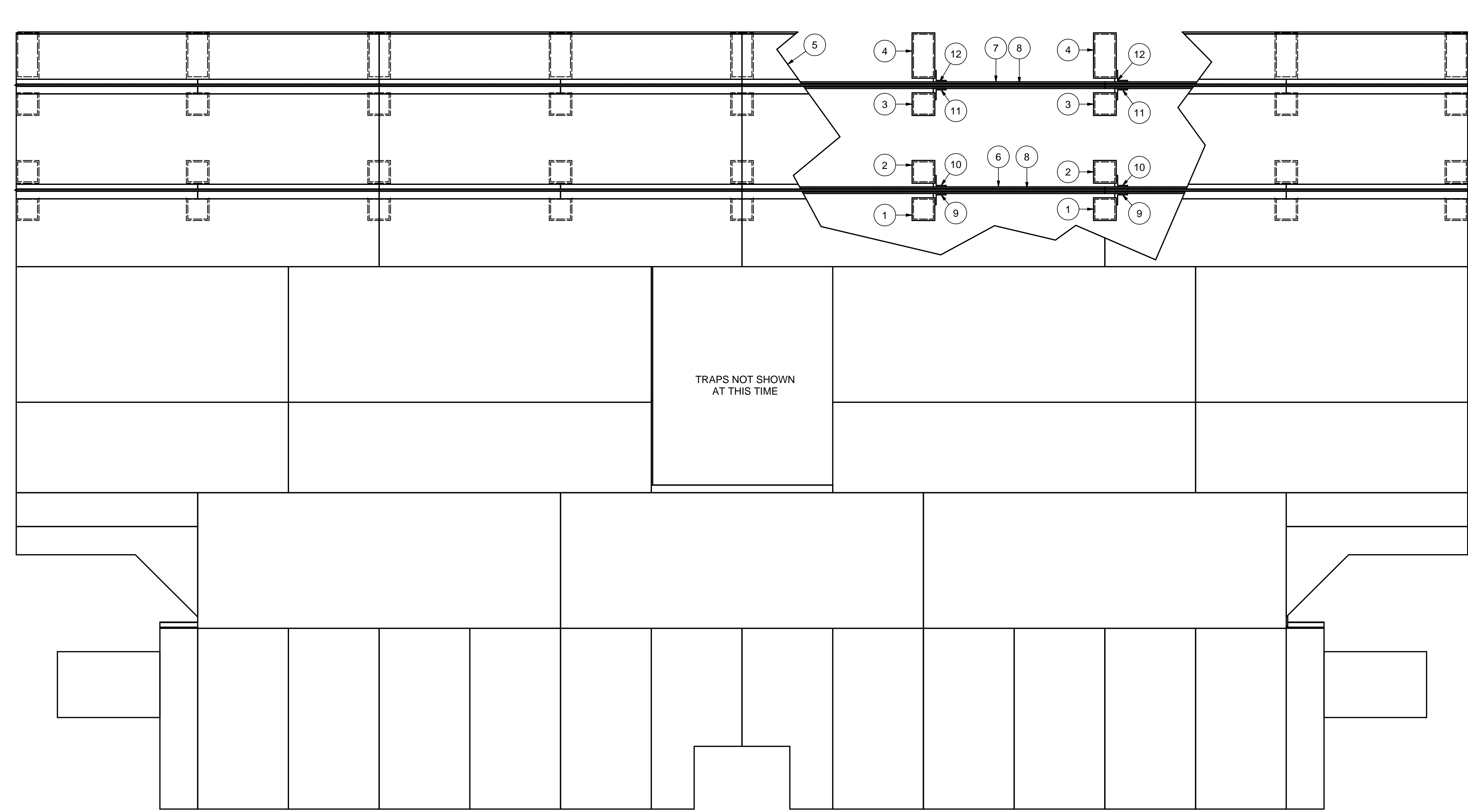

1 RAKER - PLAN
 3/8"=1'-0"

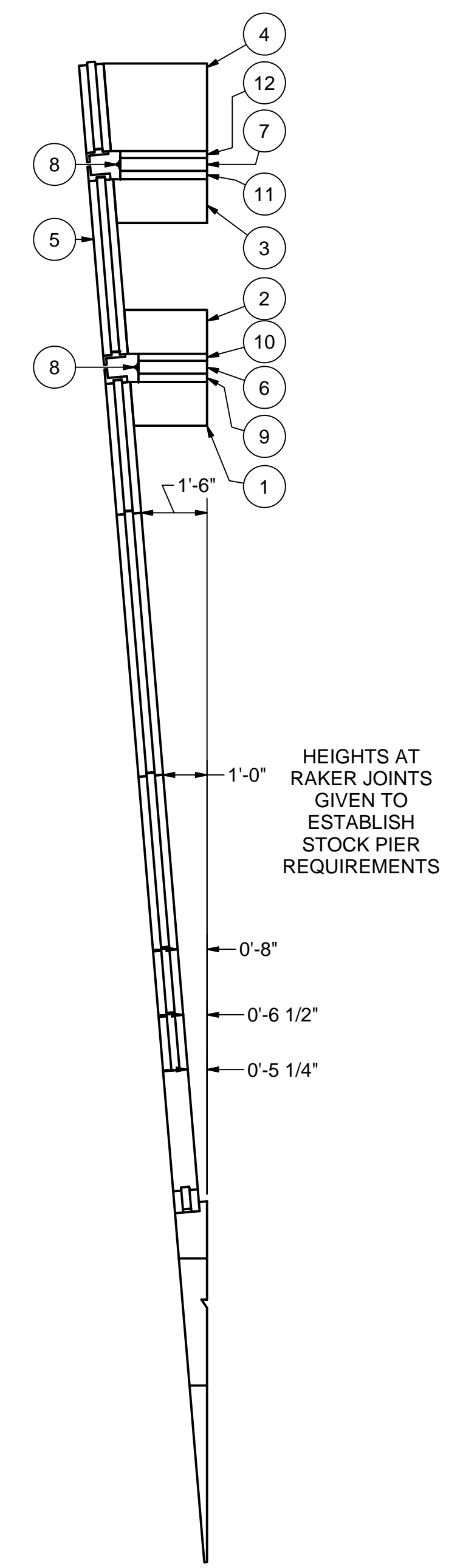

2 RAKER - SIDE
 3/8"=1'-0"

REFERENCED	
FROM	TO

JOB ID: _____
 DRAWN BY: **Ken Sly**
 APPROVED BY: _____
 ORIGINAL DATE: **2/8/2012**
 DUE DATE: _____
 SCALE: **3/8"=1'-0"**

DK1
 LATEST REVISION **A**

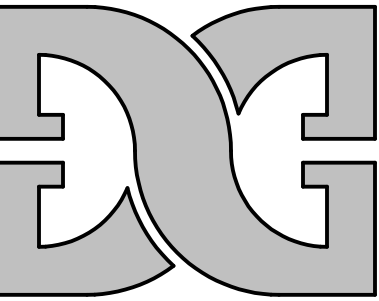

DIMENSIONAL GRAPHICS
 PHONE & FAX (650) 342-5724
 kenny@dimensionalgraphics.com
 www.dgflow.com

MATERIAL CALLOUTS ARE TO CLARIFY THE DESIGN INTENT. ALL DESIGN CONCEPTS AND MATERIALS MUST BE VERIFIED BY A LICENSED ENGINEER.

RAKER DETAIL
SAN FRANCISCO OPERA
MAGIC FLUTE 2012

Parts List			
ITEM	QTY	PART NUMBER	DESCRIPTION
1	9	MF Raker Pier DS Track DS	SHEET DK2 VIEWS 1-2
2	9	MF Raker Pier DS Track US	SHEET DK2 VIEWS 1-2
3	9	MF Raker Pier US Track DS	SHEET DK2 VIEWS 1-2
4	9	MF Raker Pier US Track US	SHEET DK2 VIEWS 1-2
5	1	MF Raked Stage deck	SHEET DK4
6	4	MF Track Pony Wall DS	SHEET DK3 VIEWS 1-2
7	4	MF Track Pony Wall US	SHEET DK3 VIEWS 3-4
8	8	English Track 16ft	STANDARD TRACK 2 LENGTHS @ 64' EACH
9	9	MF Track DS Pony DS Hog	SHEET DK2 VIEWS 1-2
10	9	MF Track DS Pony US Hog	SHEET DK2 VIEWS 1-2
11	9	MF Track US Pony DS Hog	SHEET DK2 VIEWS 1-2
12	9	MF Track US Pony US Hog	SHEET DK2 VIEWS 1-2

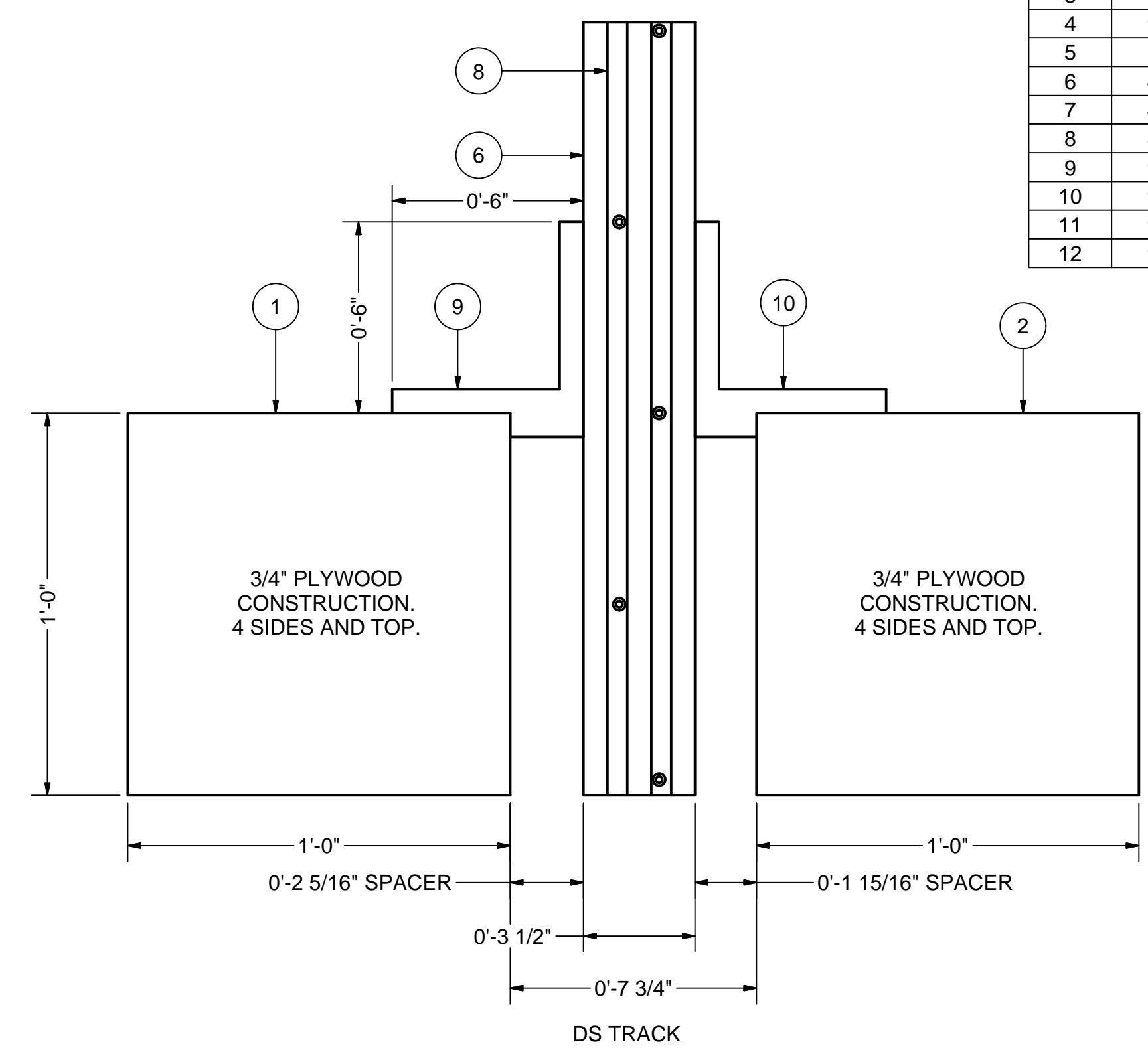

1 PIERS & TRACK - PLAN
 3"=1'-0"

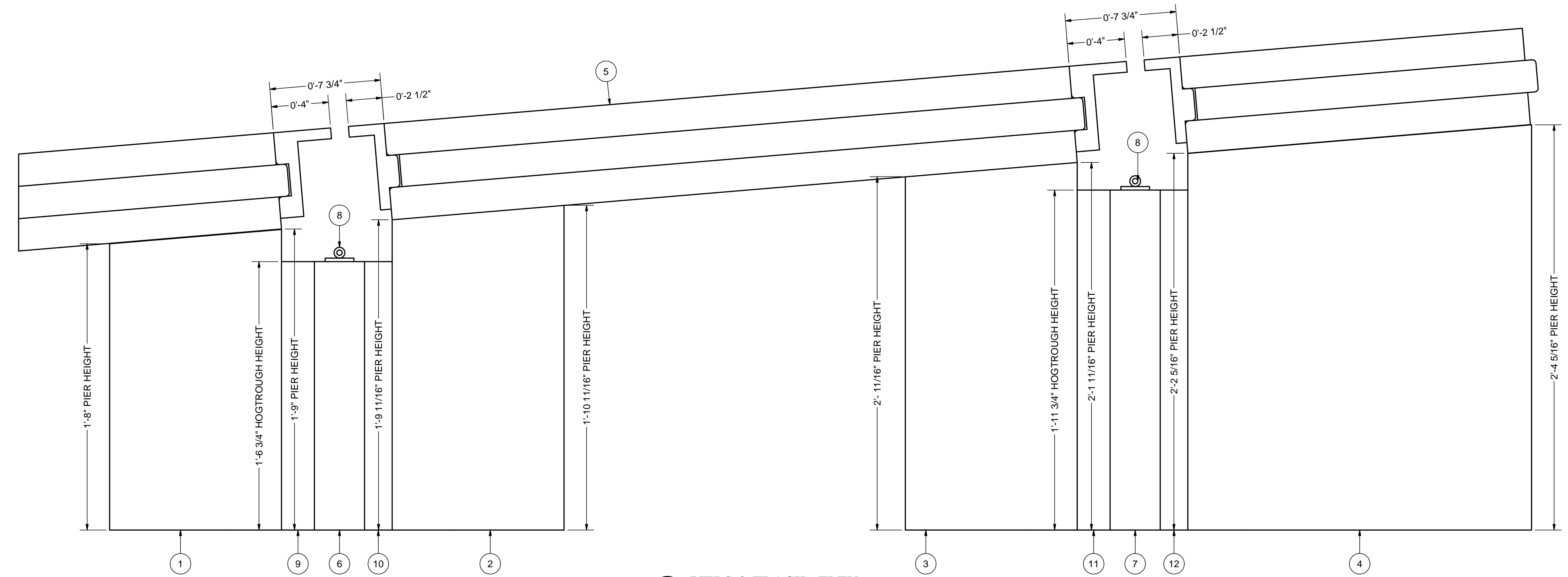
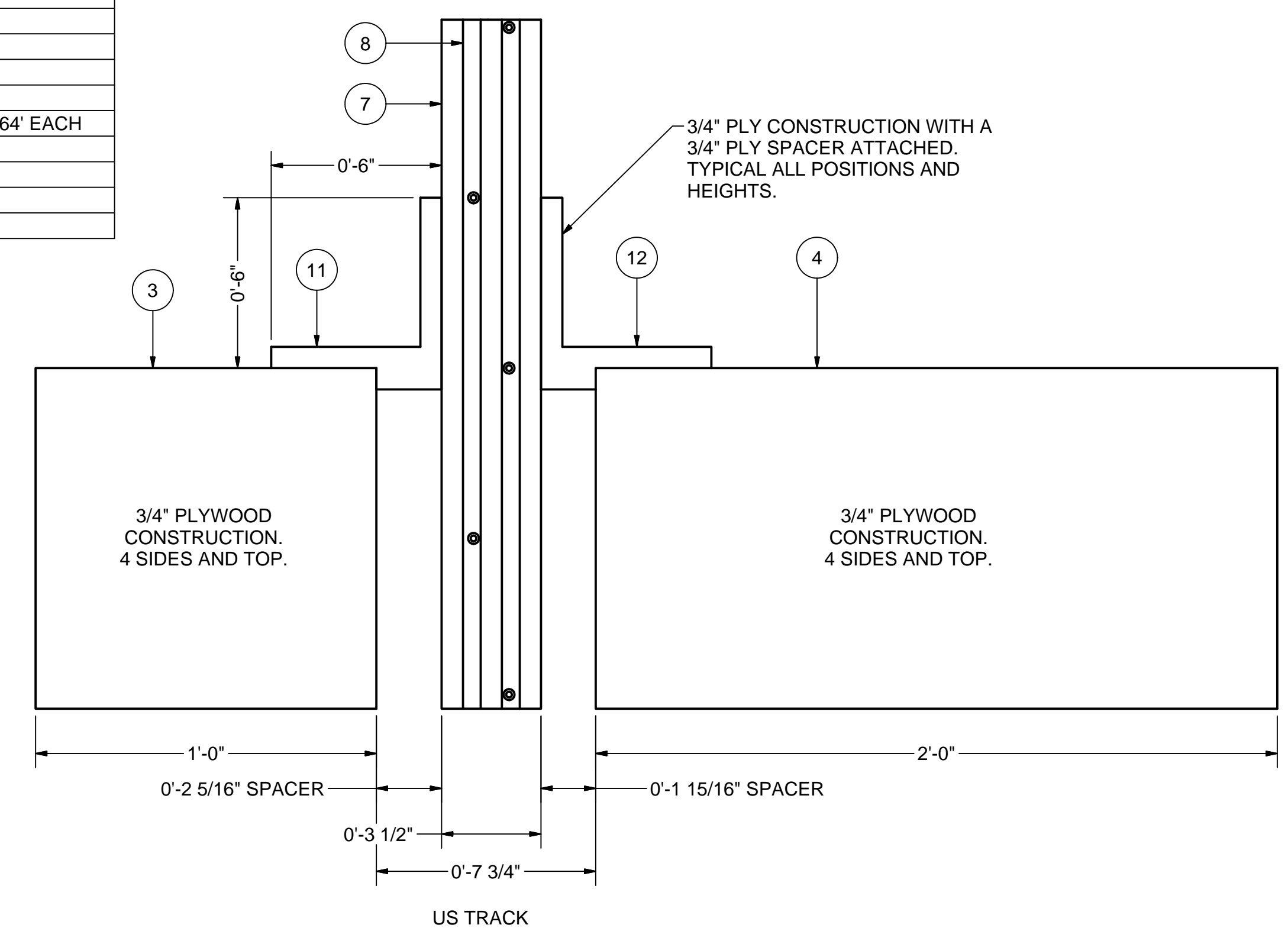

2 PIERS & TRACK - ELEV
 3"=1'-0"

REFERENCED	
FROM	TO

JOB ID: _____
 DRAWN BY: **Ken Sly**
 APPROVED BY: _____
 ORIGINAL DATE: **2/8/2012**
 DUE DATE: _____
 SCALE: **3"=1'-0"**
DK2
 LATEST REVISION **A**

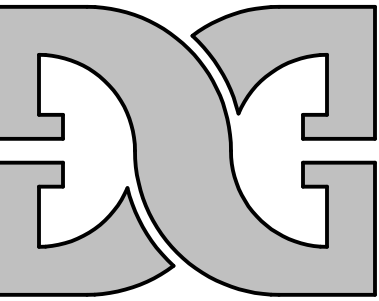

DIMENSIONAL GRAPHICS
 PHONE & FAX (650) 342-5724
 ken@dgflow.com
 www.dgflow.com
MATERIAL CALLOUTS ARE TO CLARIFY THE DESIGN INTENT. ALL DESIGN CONCEPTS AND MATERIALS MUST BE VERIFIED BY A LICENSED ENGINEER.

TRACK PONY WALLS
SAN FRANCISCO OPERA
MAGIC FLUTE 2012

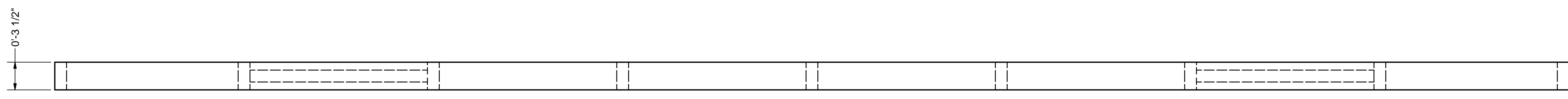

1 PONY WALL DS - PLAN
 1-1/2"=1'-0"
 4 REQUIRED

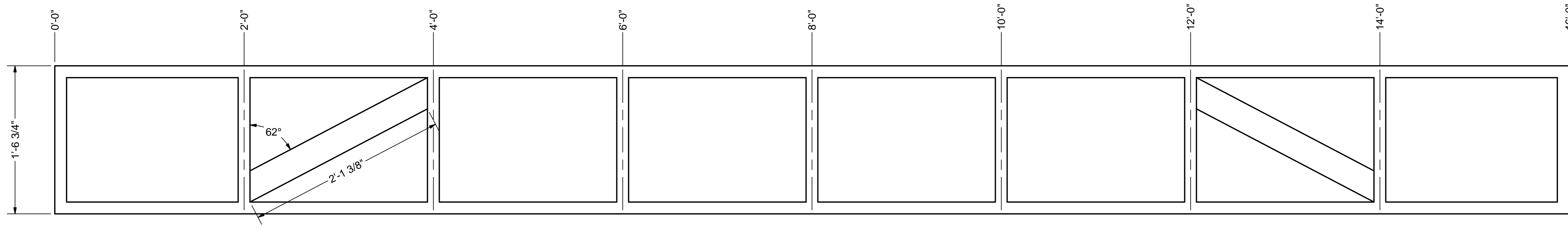

2x4 CONSTRUCTION TYPICAL

DRILL ENDS AS NEEDED TO BOLT SECTIONS TOGETHER INTO A 64' LONG PONY WALL.

2 PONY WALL DS - ELEV
 1-1/2"=1'-0"
 4 REQUIRED

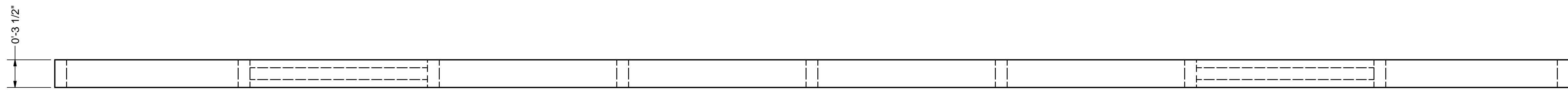

3 PONY WALL US - PLAN
 1-1/2"=1'-0"
 4 REQUIRED

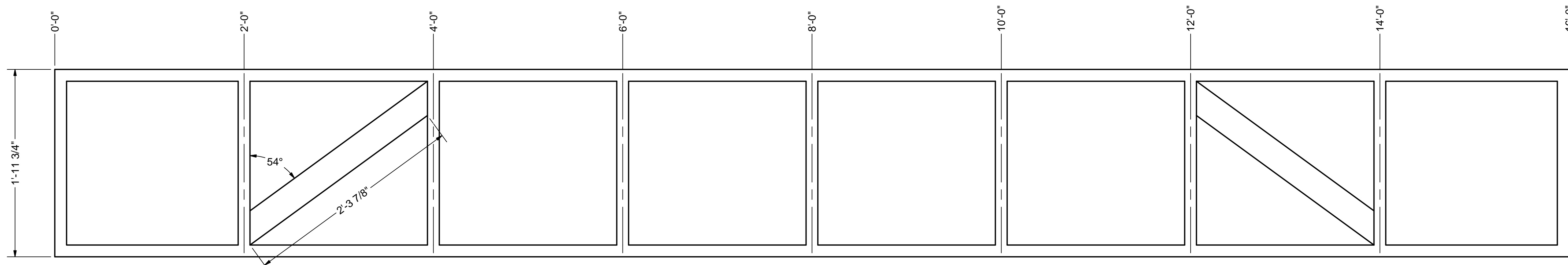

2x4 CONSTRUCTION TYPICAL

DRILL ENDS AS NEEDED TO BOLT SECTIONS TOGETHER INTO A 64' LONG PONY WALL.

4 PONY WALL US - ELEV
 1-1/2"=1'-0"
 4 REQUIRED

REFERENCED	
FROM	TO

JOB ID: _____
 DRAWN BY: **Ken Sly**
 APPROVED BY: _____
 ORIGINAL DATE: **2/8/2012**
 DUE DATE: _____
 SCALE: **1-1/2"=1'-0"**

DK3
 LATEST REVISION **A**

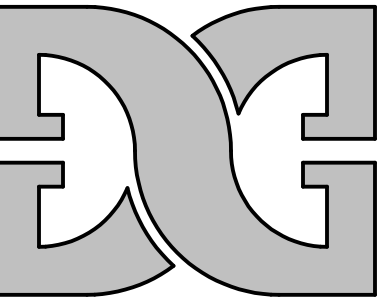

DIMENSIONAL GRAPHICS
 PHONE & FAX (650) 342-5724
 kenny@dgflow.com
 www.dgflow.com
MATERIAL CALLOUTS ARE TO CLARIFY THE DESIGN INTENT. ALL DESIGN CONCEPTS AND MATERIALS MUST BE VERIFIED BY A LICENSED ENGINEER.

PAGODA TOP ASSEMBLY
SAN FRANCISCO OPERA
MAGIC FLUTE 2012

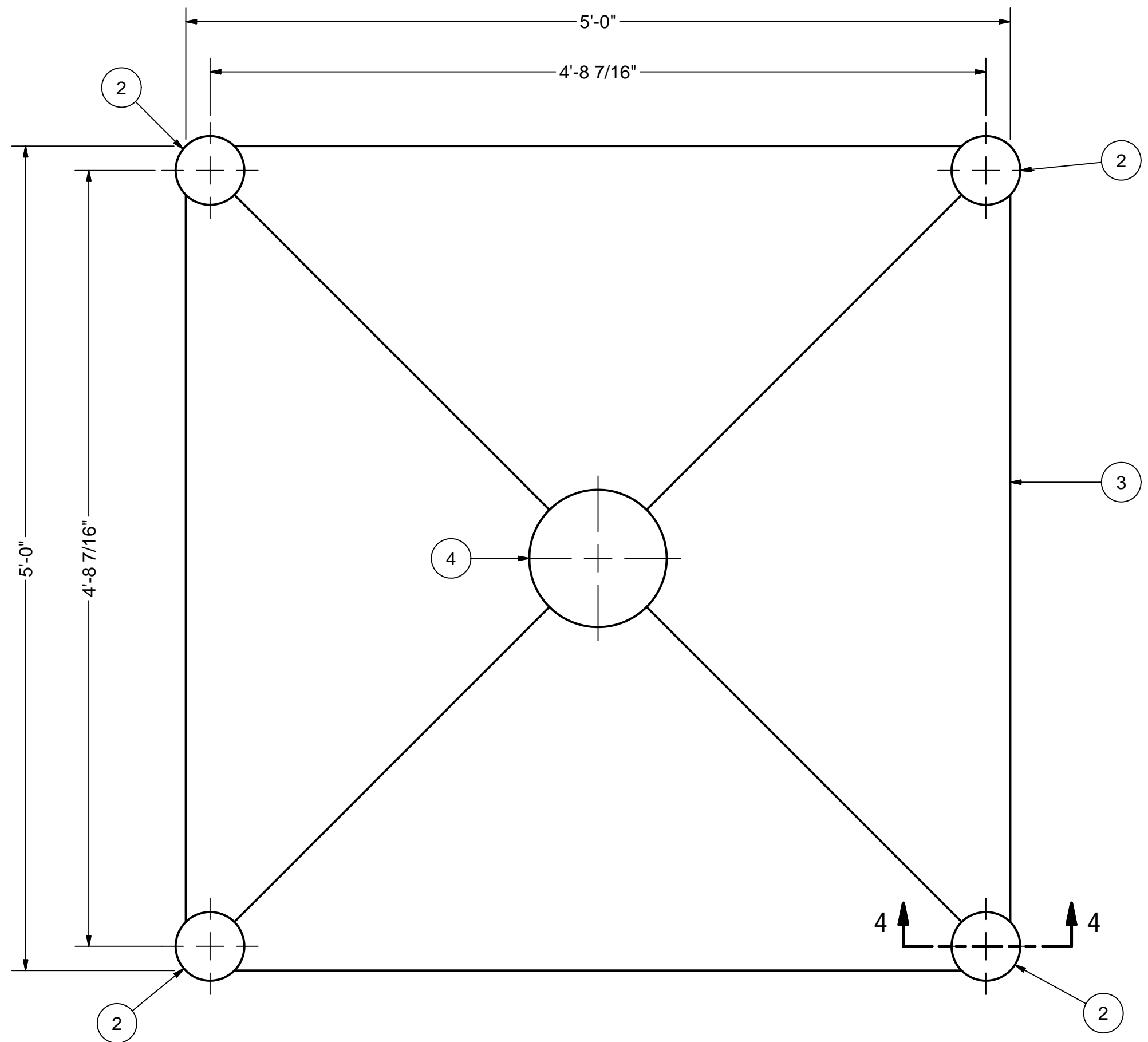

1 **PAGODA TOP ASSM - PLAN**
 1-1/2"=1'-0"
 1 REQUIRED

Parts List				
ITEM	QTY	PART NUMBER	DESCRIPTION	
1	1	MF Pagoda Top Frame	SHEET P3	
2	4	MF Pagoda Pole Cap	SHEET P7 VIEWS 1-2	
3	1	MF Pagoda Top Skin	1/4" LAUAN COVERING FRAME AFTER COMPONENTS ASSEMBLED	
4	1	MF Pagoda Top Ball	Wagner 4187 10" Aluminum Alloy 3003 Sphere	

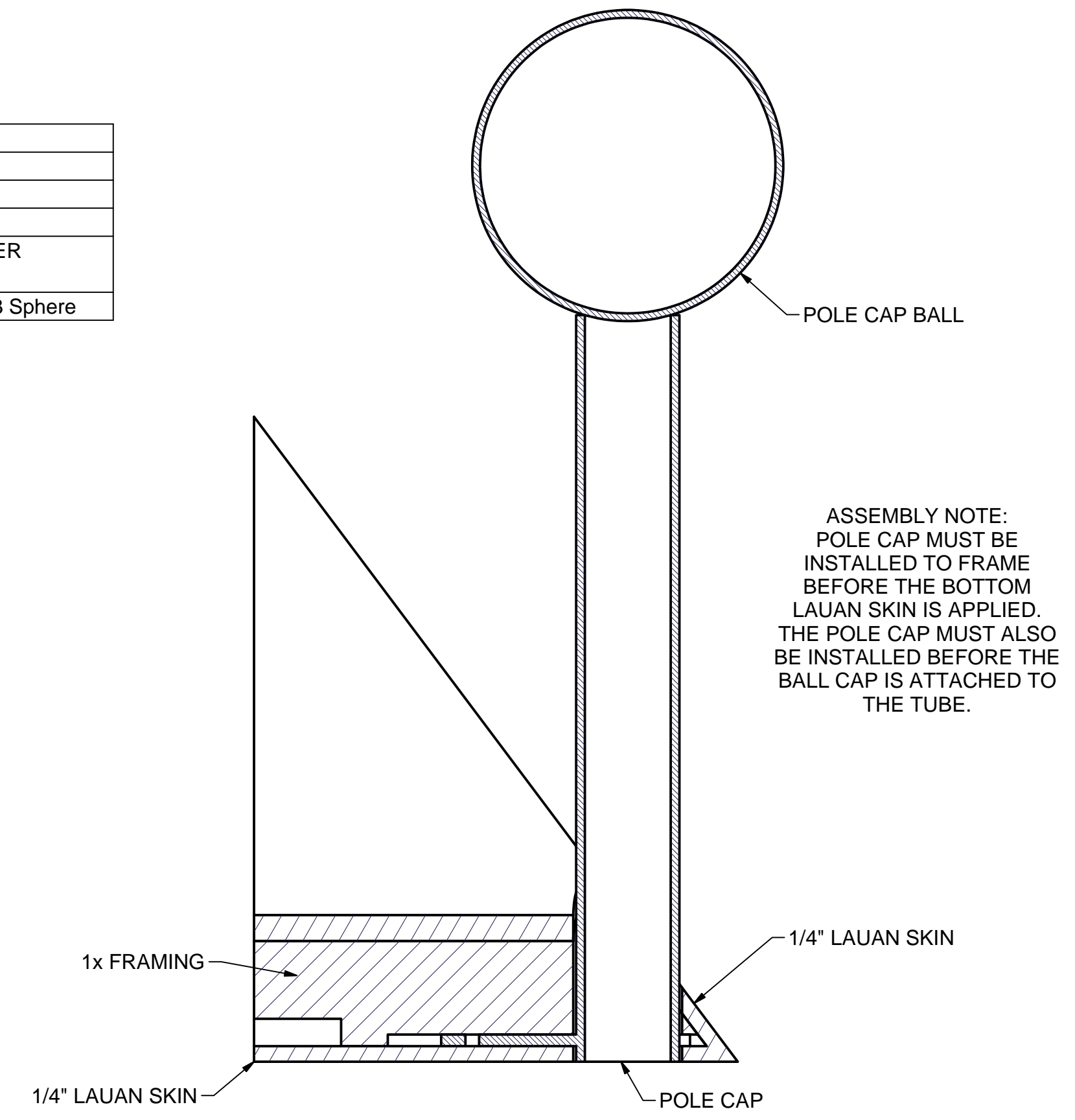

4 **SECTION**
 HALF SIZE

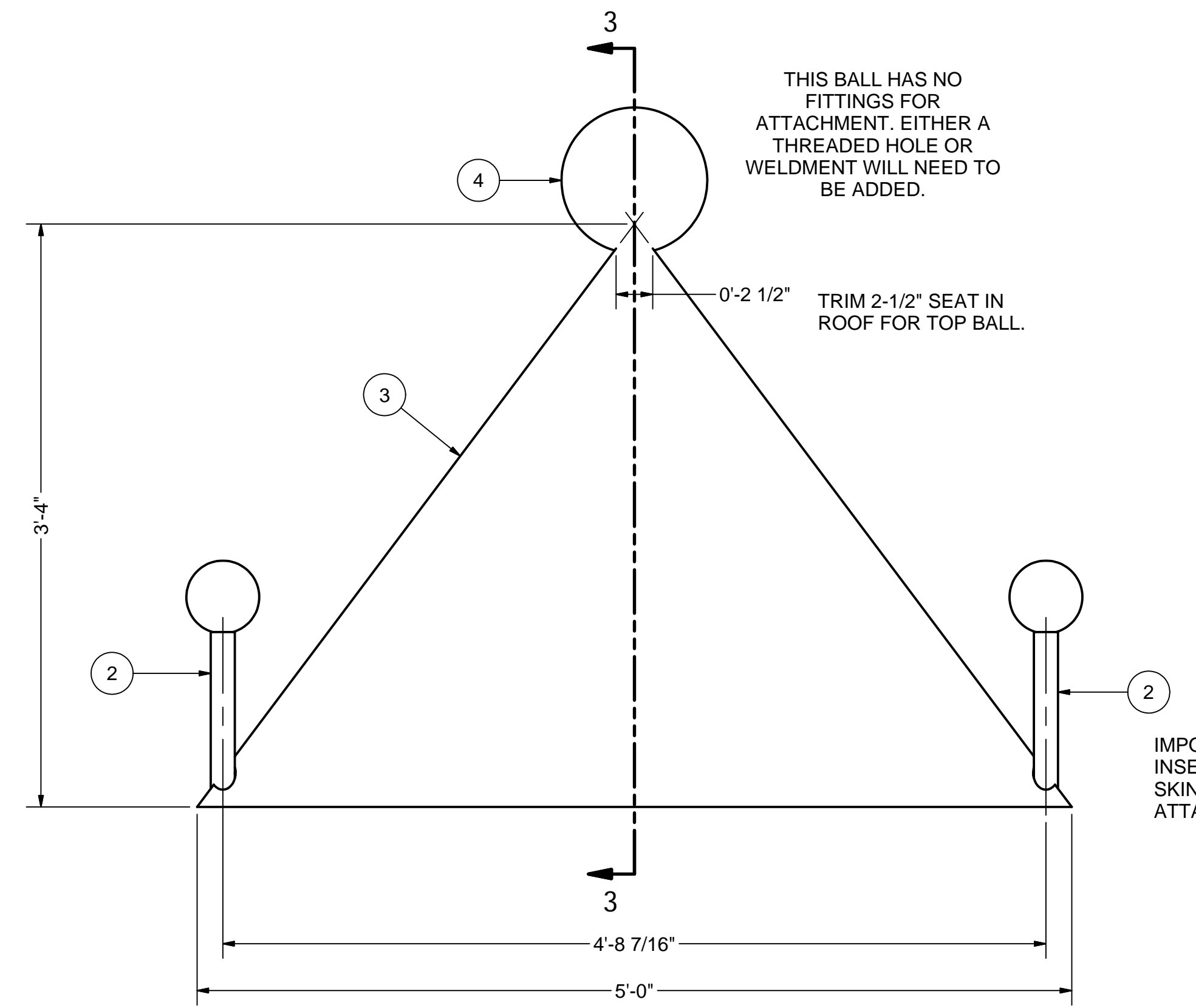

2 **PAGODA TOP ASSM - TYP ELEV**
 1-1/2"=1'-0"
 1 REQUIRED

IMPORTANT ASSEMBLY NOTE:
 INSERT POLE CAP [2] INTO FRAME BEFORE SKINNING BOTTOM OF FRAME AND BEFORE ATTACHING BALL TOP.

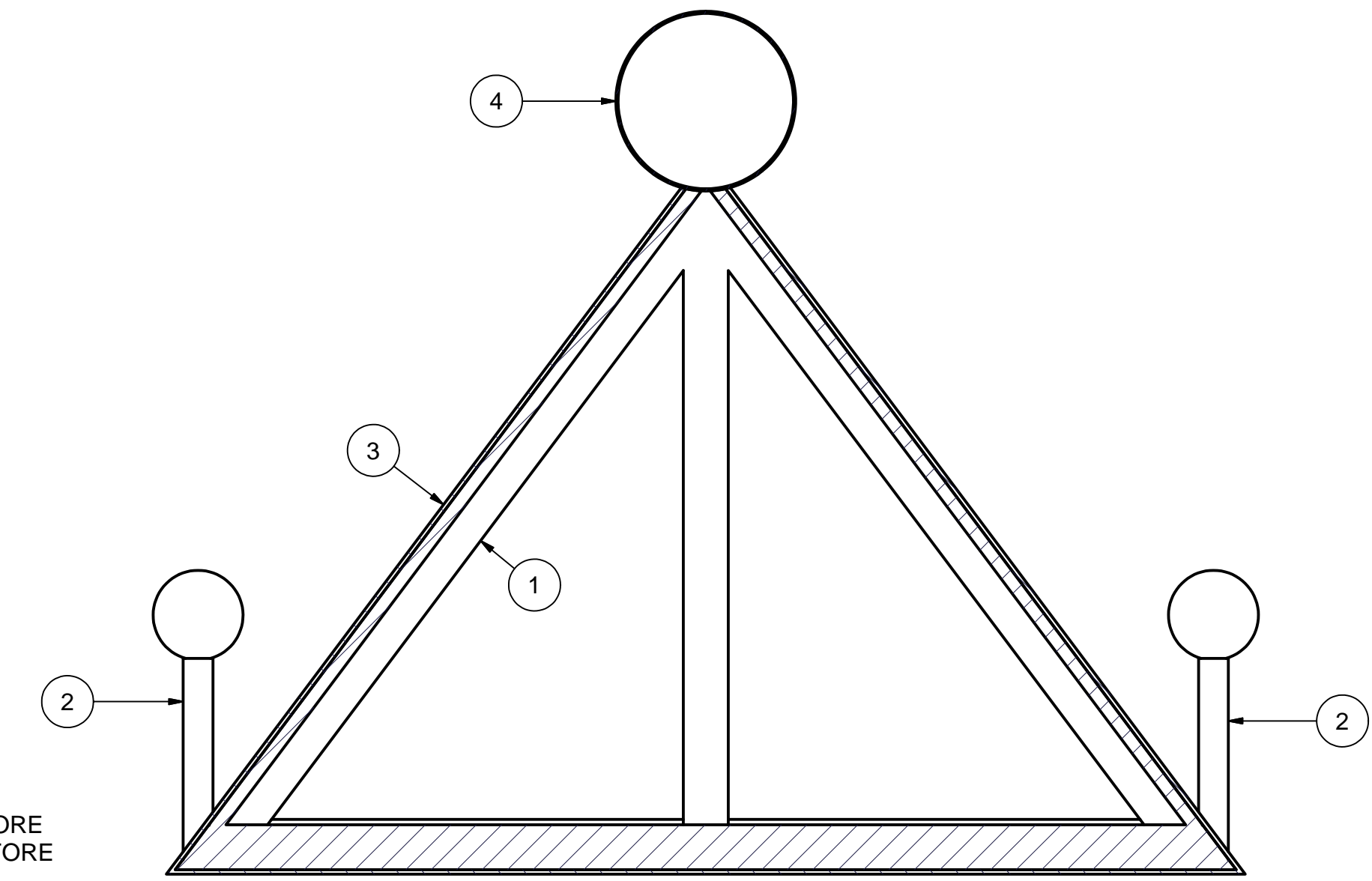

3 **SECTION**
 1-1/2"=1'-0"

REFERENCED	
FROM	TO

JOB ID: _____
 DRAWN BY: **Ken Sly**
 APPROVED BY: _____
 ORIGINAL DATE: **2/8/2012**
 DUE DATE: _____
 SCALE: **AS NOTED**
P2
 LATEST REVISION **A**

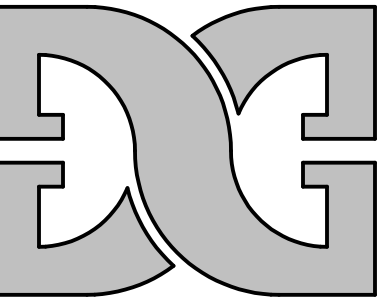

DIMENSIONAL GRAPHICS
 PHONE & FAX (650) 342-5724
 ken@dgflow.com
 www.dgflow.com
 MATERIAL CALLOUTS ARE TO CLARIFY THE DESIGN INTENT. ALL DESIGN CONCERNS AND MATERIALS MUST BE VERIFIED BY A LICENSED ENGINEER.

PAGODA TOP FRAME
SAN FRANCISCO OPERA
MAGIC FLUTE 2012

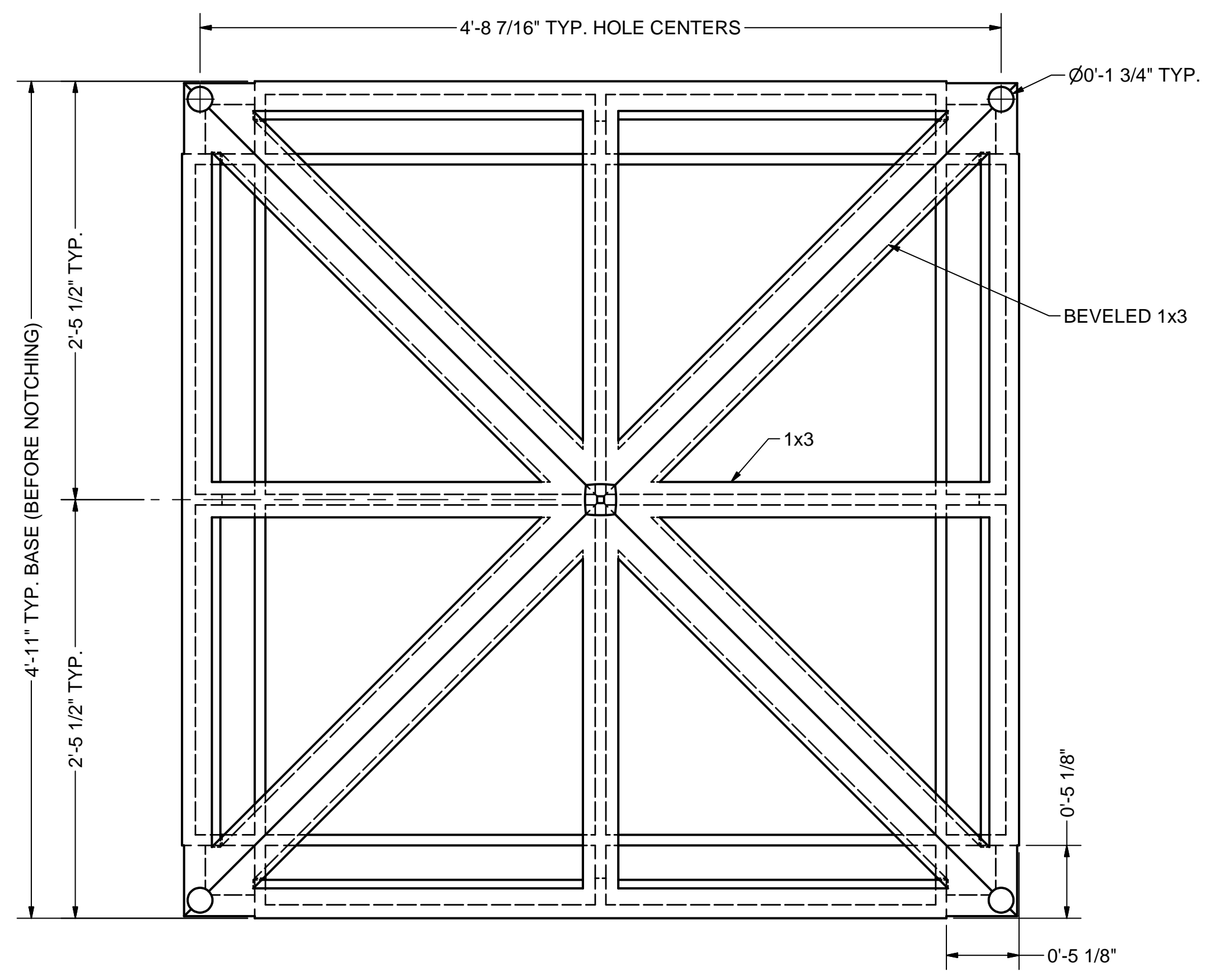

1 PAGODA ROOF FRAME - PLAN
 1-1/2"=1'-0"
 1 REQUIRED

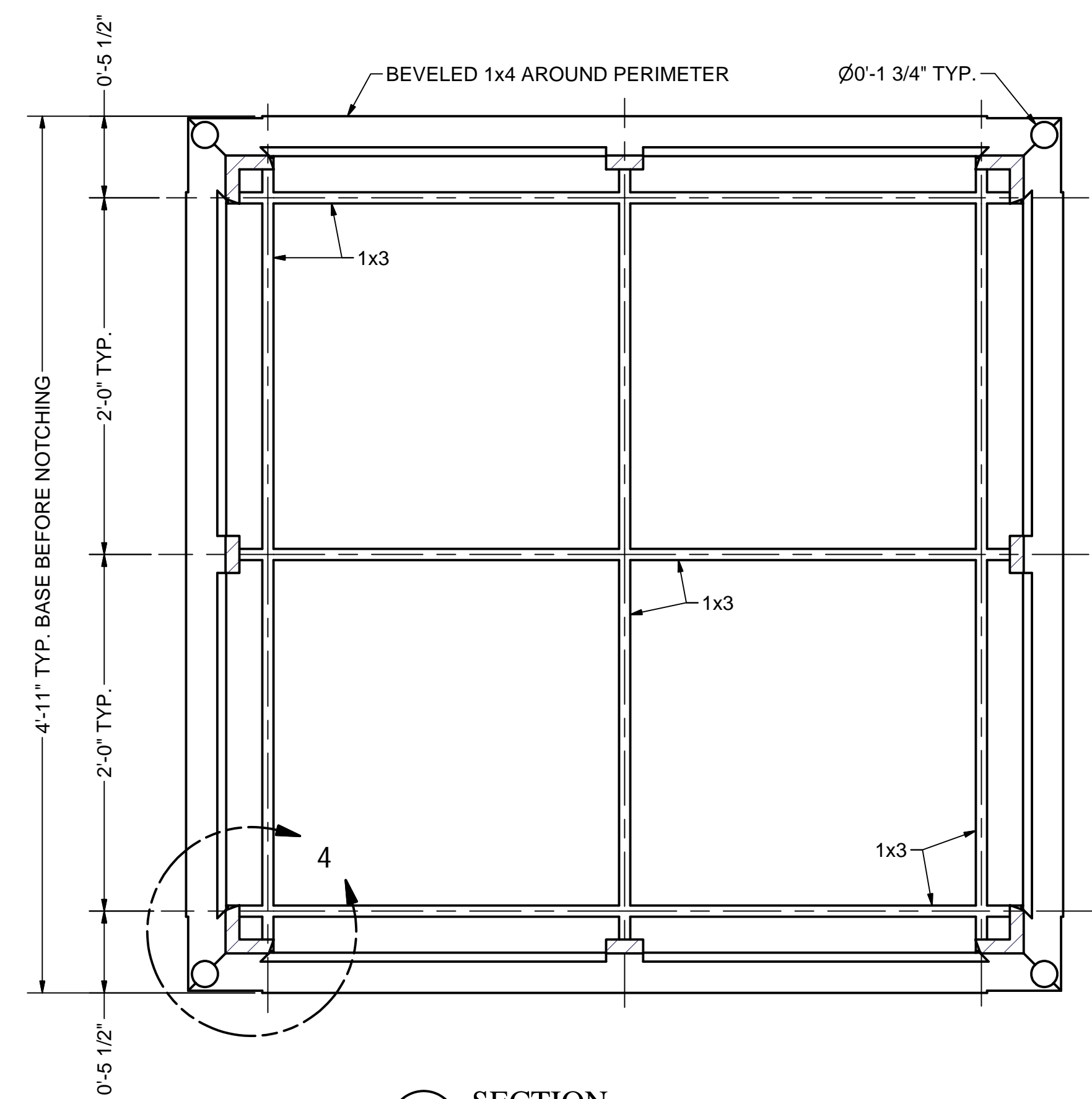

2 SECTION
 1-1/2"=1'-0"

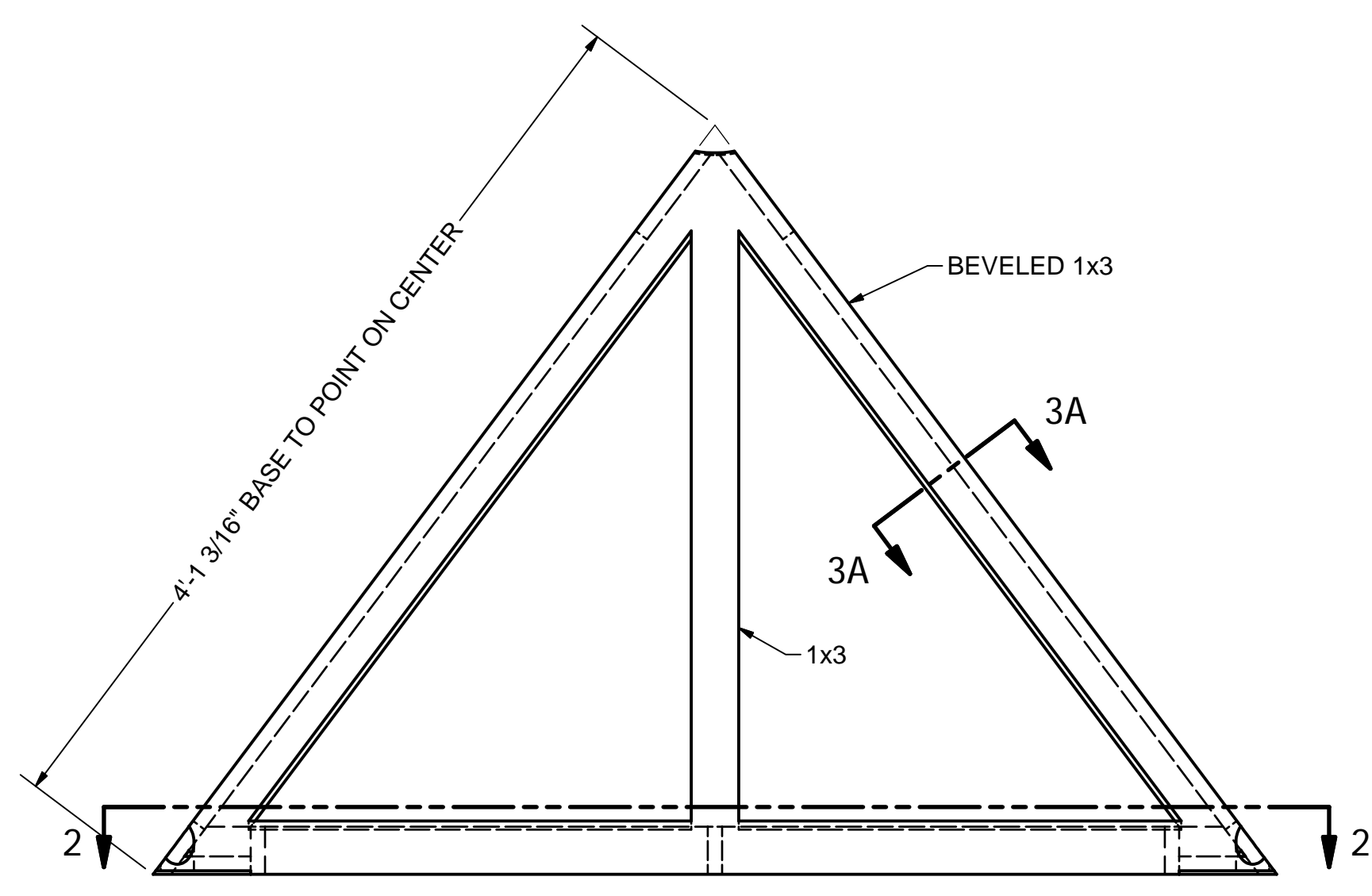

3 PAGODA ROOF FRAME - ELEV
 1-1/2"=1'-0"
 1 REQUIRED

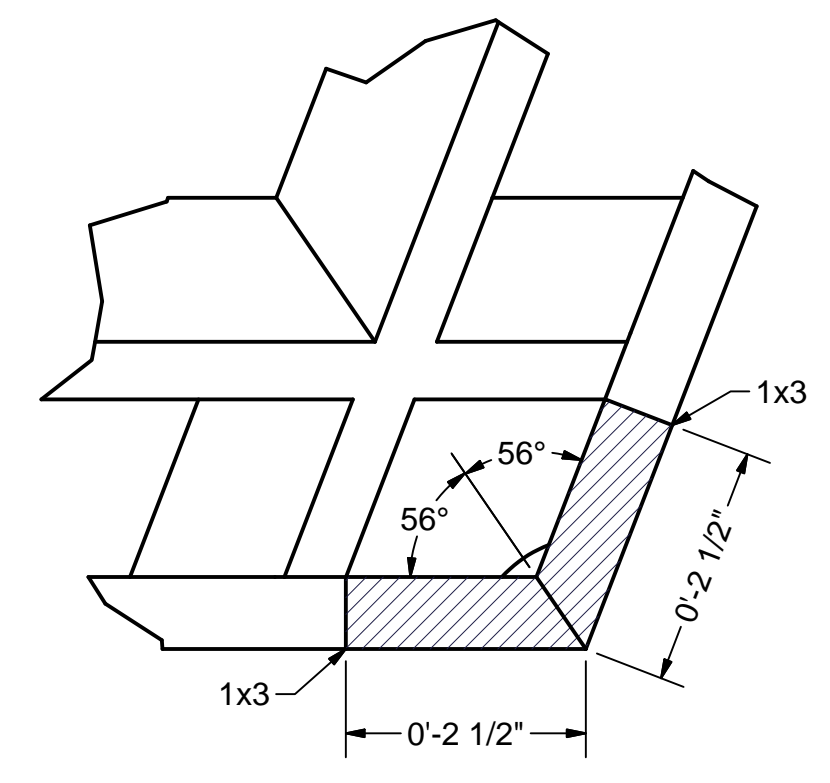

3A SECTION
 HALF SIZE
 TRUE VIEW

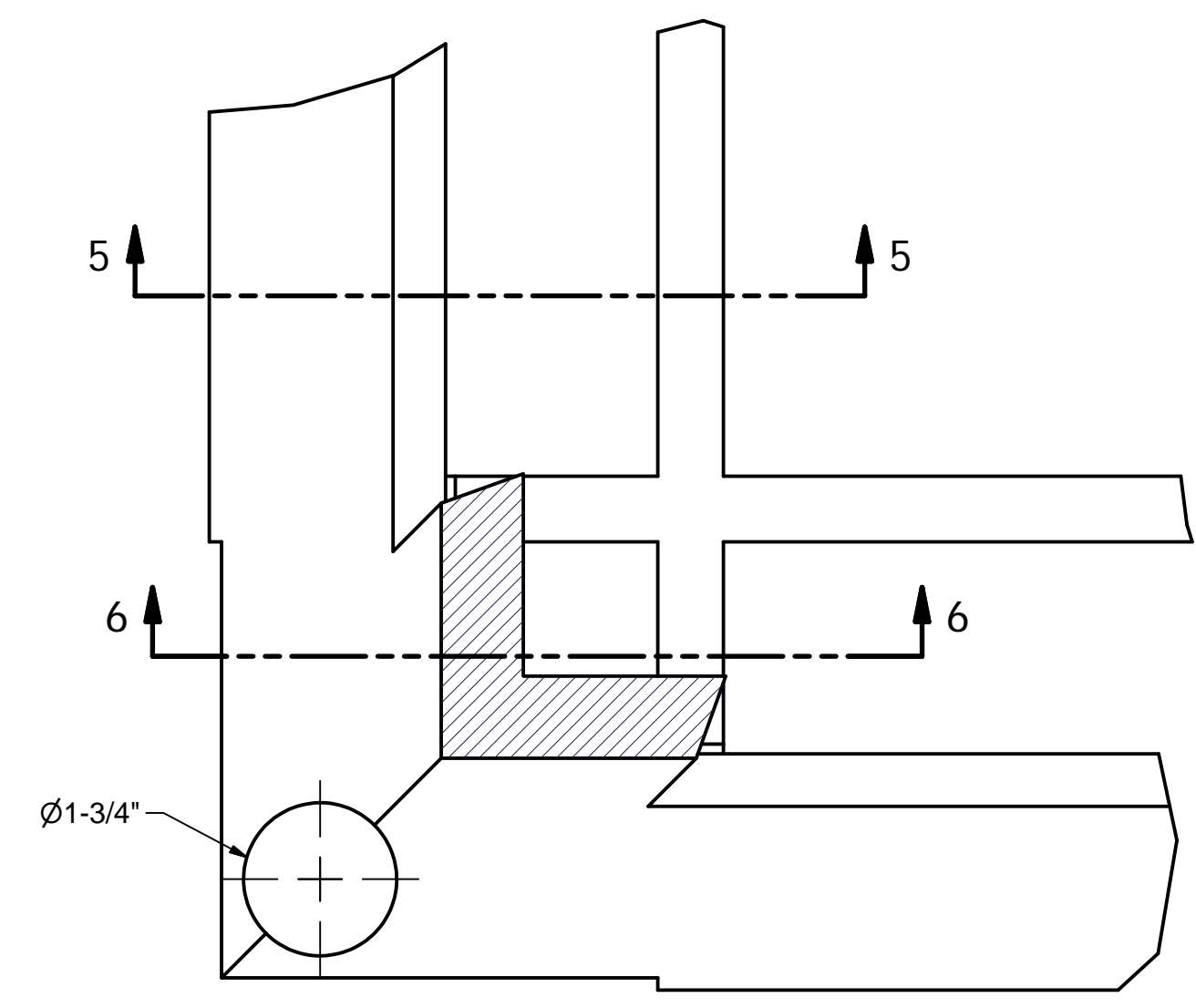

4 DETAIL
 HALF SIZE

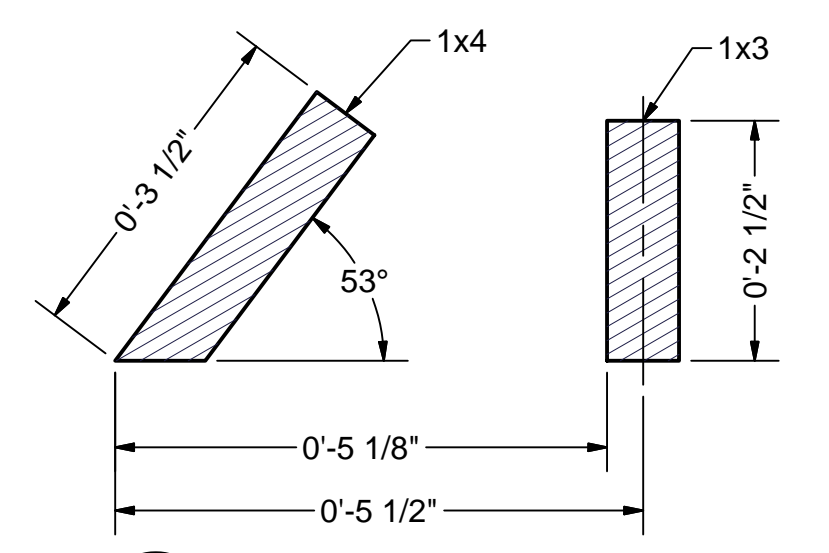

5 SECTION
 HALF SIZE

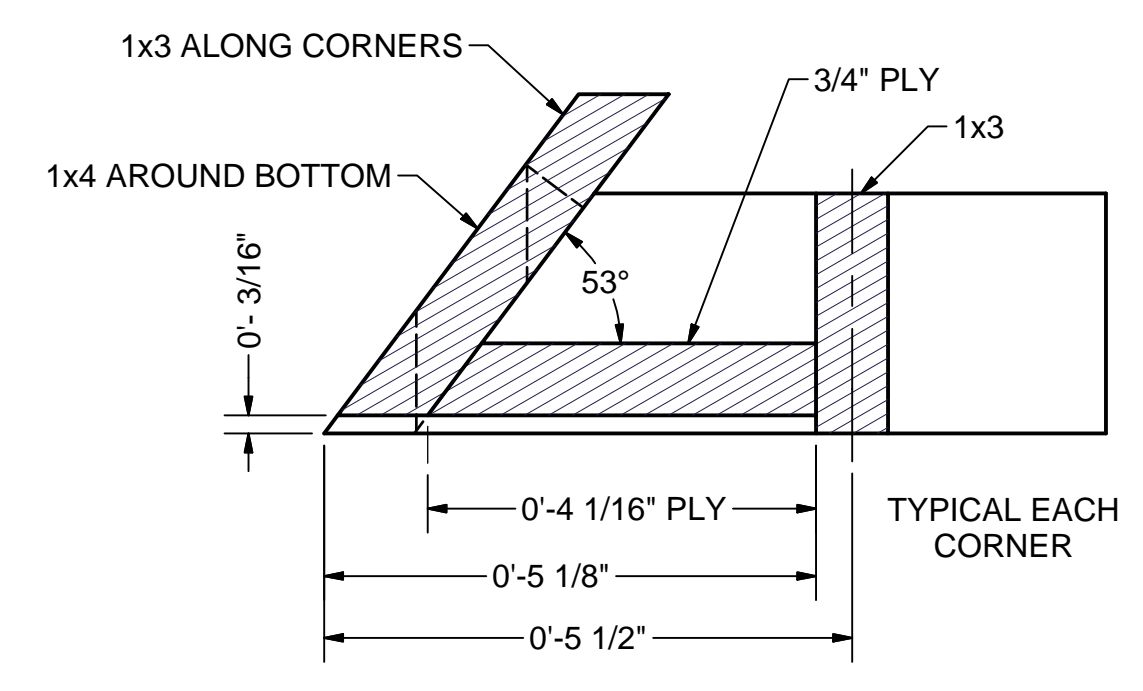

6 SECTION
 HALF SIZE

REFERENCED	
FROM	TO

JOB ID: _____
 DRAWN BY: **Ken Sly**
 APPROVED BY: _____
 ORIGINAL DATE: **2/8/2012**
 DUE DATE: _____
 SCALE: **AS NOTED**
P3
 LATEST REVISION

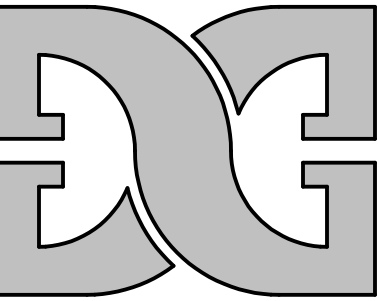

DIMENSIONAL GRAPHICS
 PHONE & FAX (650) 342-5724
 kenny@diglow.com
 www.diglow.com
 MATERIAL CALLOUTS ARE TO CLARIFY THE DESIGN INTENT. ALL DESIGN CONCERNS AND MATERIALS MUST BE VERIFIED BY A LICENSED ENGINEER.

PAGODA BASE ASSEMBLY
SAN FRANCISCO OPERA
MAGIC FLUTE 2012

Parts List				
ITEM	QTY	PART NUMBER	DESCRIPTION	
1	1	MF Pagoda Base	SHEET P5	
2	4	MF Pagoda Pole Anchor	SHEET P7 VIEWS 3-5	
3	2	MF Pagoda Dawg assm	SHEET P8 VIEWS 1-3	
4	16	ANSI/ASME B18.2.1 - 3/8-16 UNC - 1.5	Hex Bolt - UNC (Regular Thread - Inch)	
5	32	ANSI B18.22.1 - 3/8 - narrow - Type A	Plain Washer (Inch)Type A and B	
6	16	ANSI B18.2.2 - 3/8 - 16	Hex Nuts (Inch Series) Hex Nut	

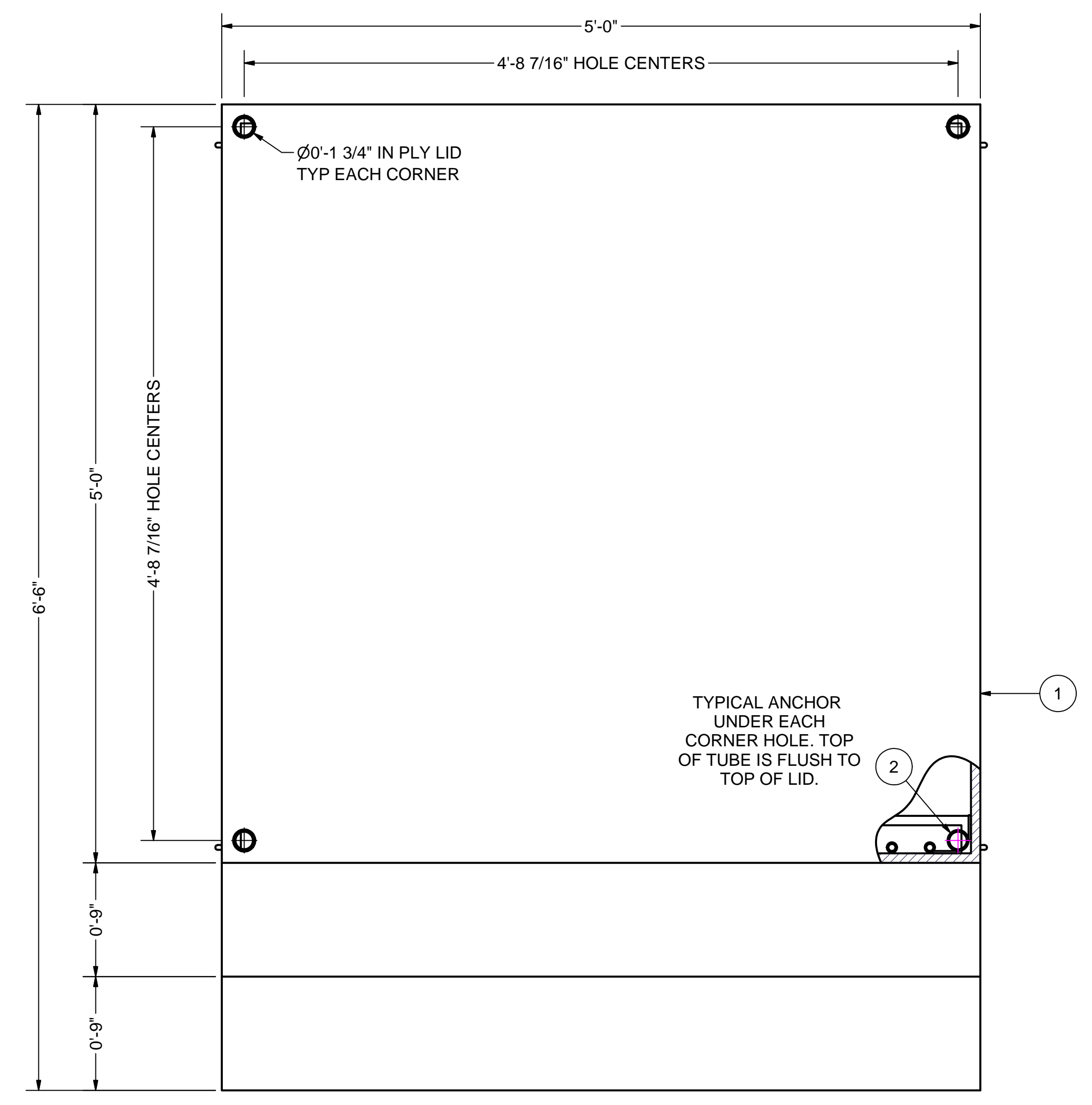

1 PAGODA BASE ASSM - PLAN
 1-1/2"=1'-0"
 1 REQUIRED

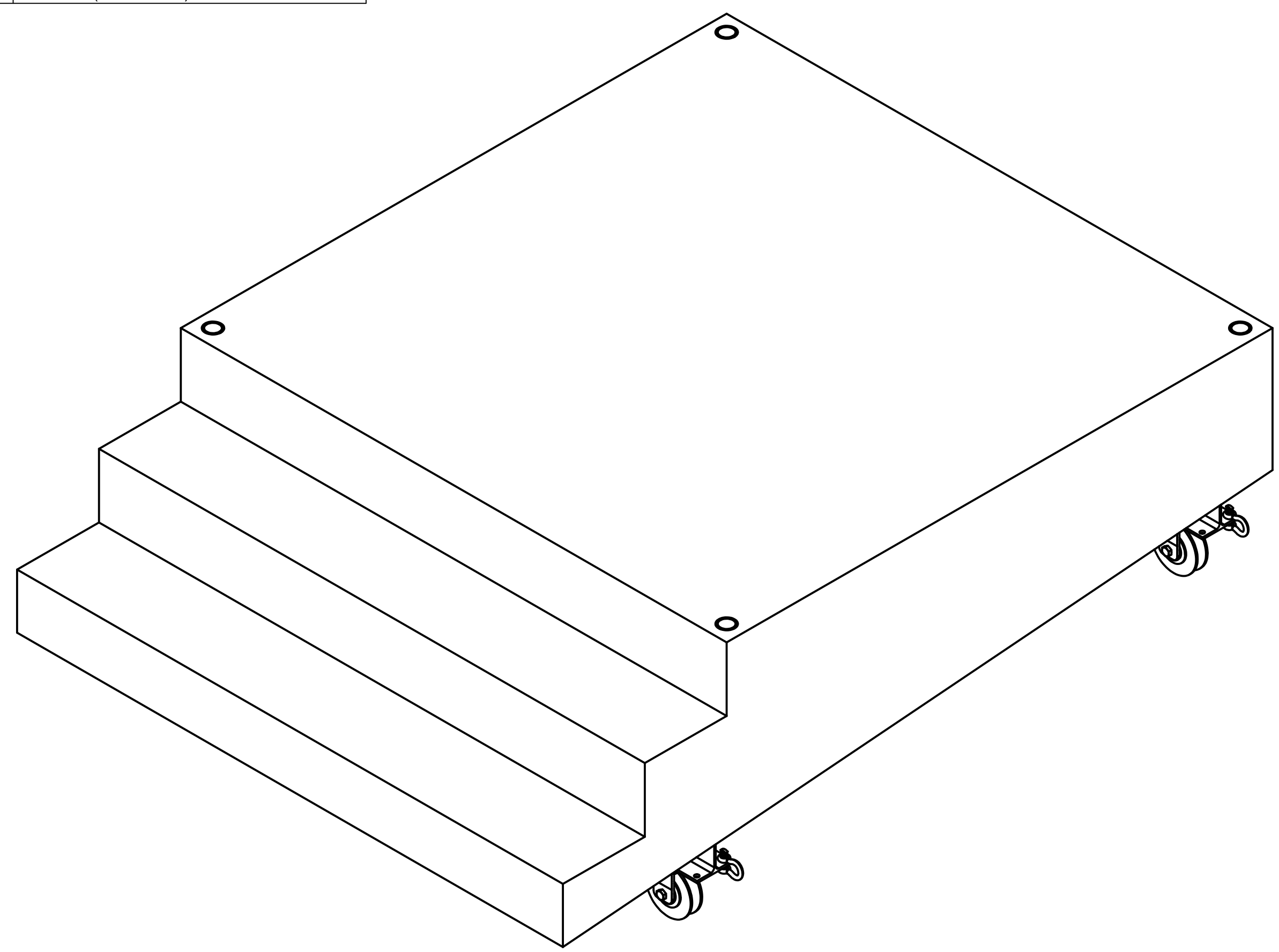

2 PAGODA BASE ASSM - ISO
 1-1/2"=1'-0"
 1 REQUIRED

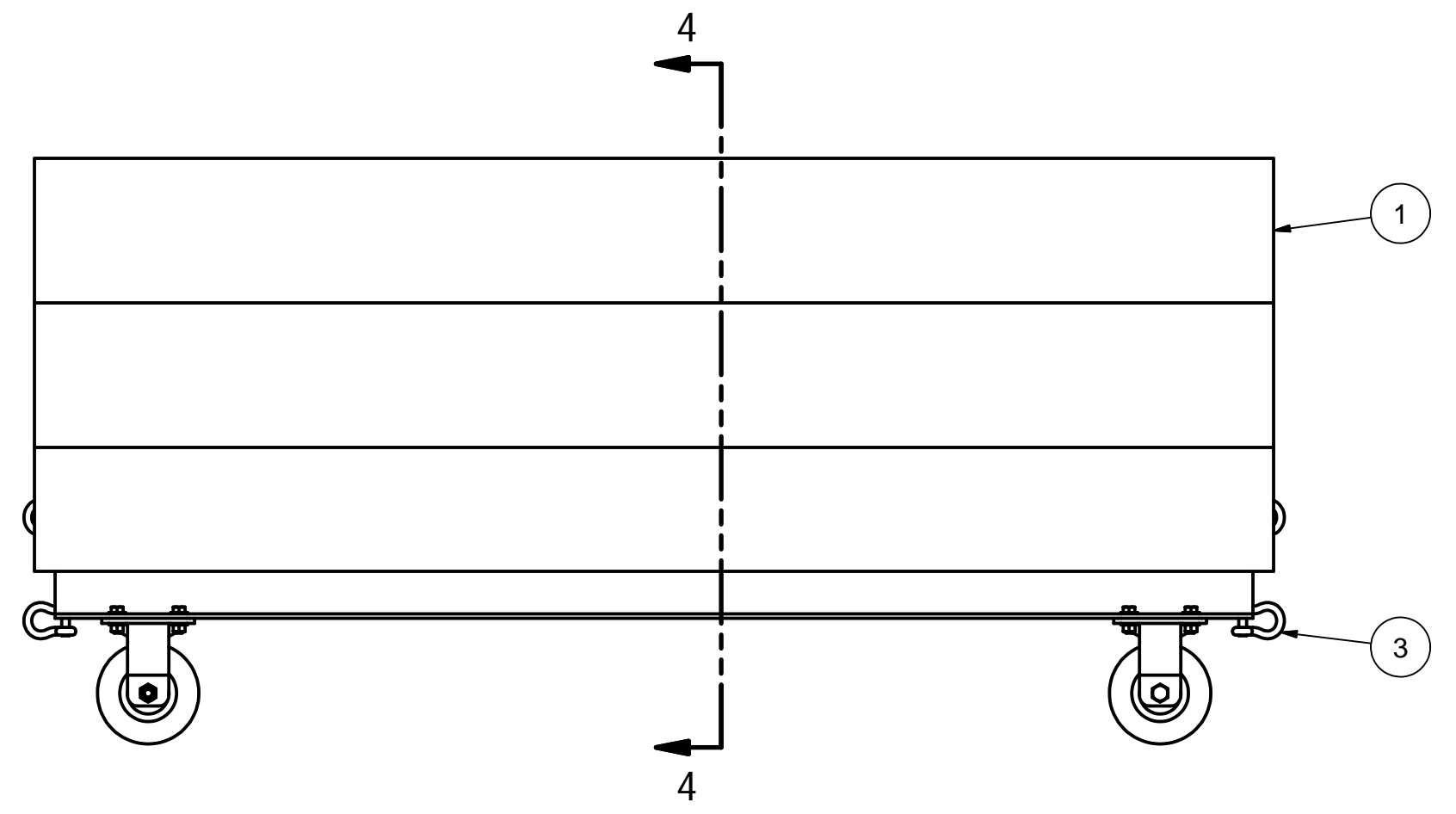

3 PAGODA BASE ASSM - DS ELEV
 1-1/2"=1'-0"
 1 REQUIRED

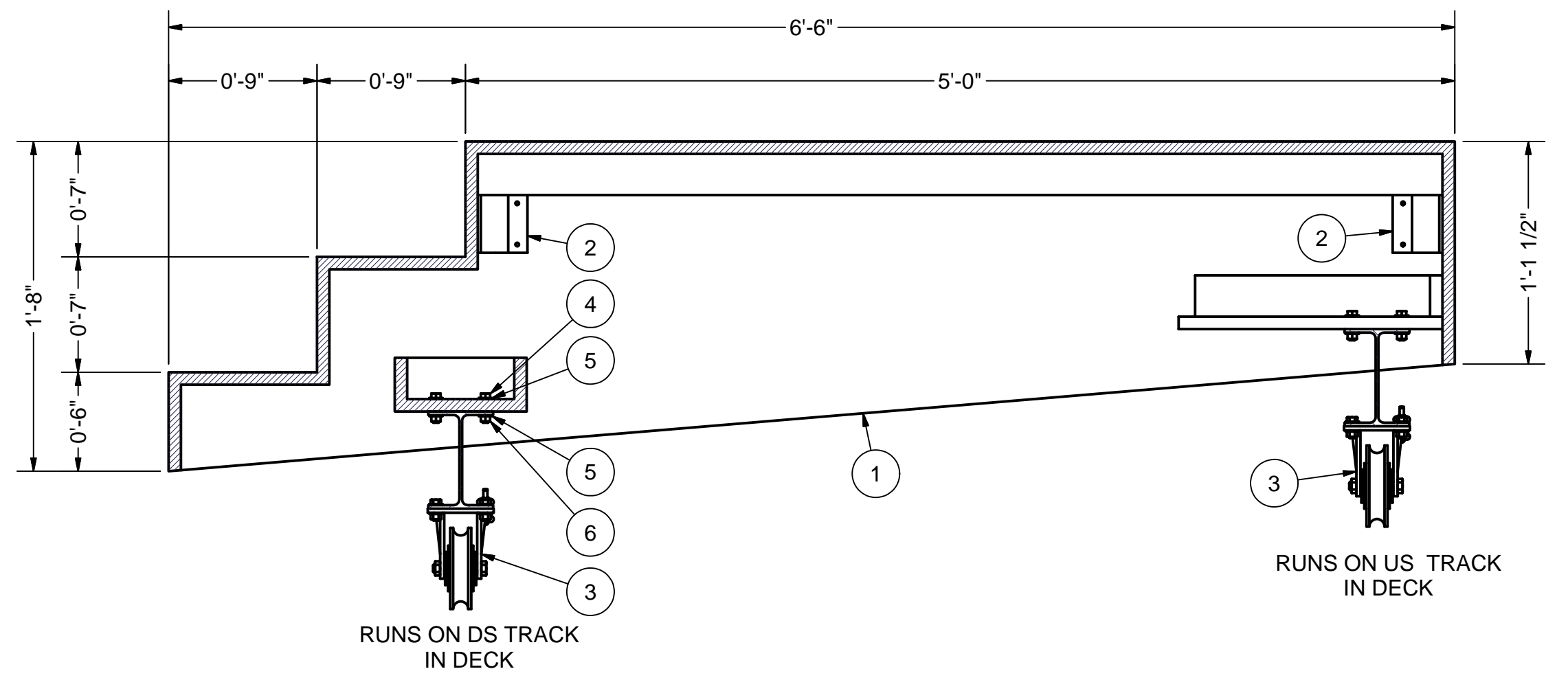

4 SECTION
 1-1/2"=1'-0"

REFERENCED	
FROM	TO

JOB ID:
 DRAWN BY: Ken Sly
 APPROVED BY:
 ORIGINAL DATE: 2/8/2012
 DUE DATE:
 SCALE: 1-1/2"=1'-0"

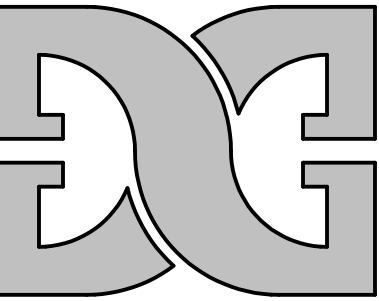

DIMENSIONAL GRAPHICS
 PHONE & FAX (650) 342-5724
 kenny@dimensionalgraphics.com
 www.dgflow.com
MATERIAL CALLOUTS ARE TO CLARIFY THE DESIGN INTENT. ALL DESIGN CONCEPTS AND MATERIALS MUST BE VERIFIED BY A LICENSED ENGINEER.

**PAGODA METAL PARTS
 SAN FRANCISCO OPERA
 MAGIC FLUTE 2012**

REFERENCED	
FROM	TO

JOB ID: _____
 DRAWN BY: Ken Sly
 APPROVED BY: _____
 ORIGINAL DATE: 2/8/2012
 DUE DATE: _____
 SCALE: HALF SIZE
P6
LATEST REVISION

A

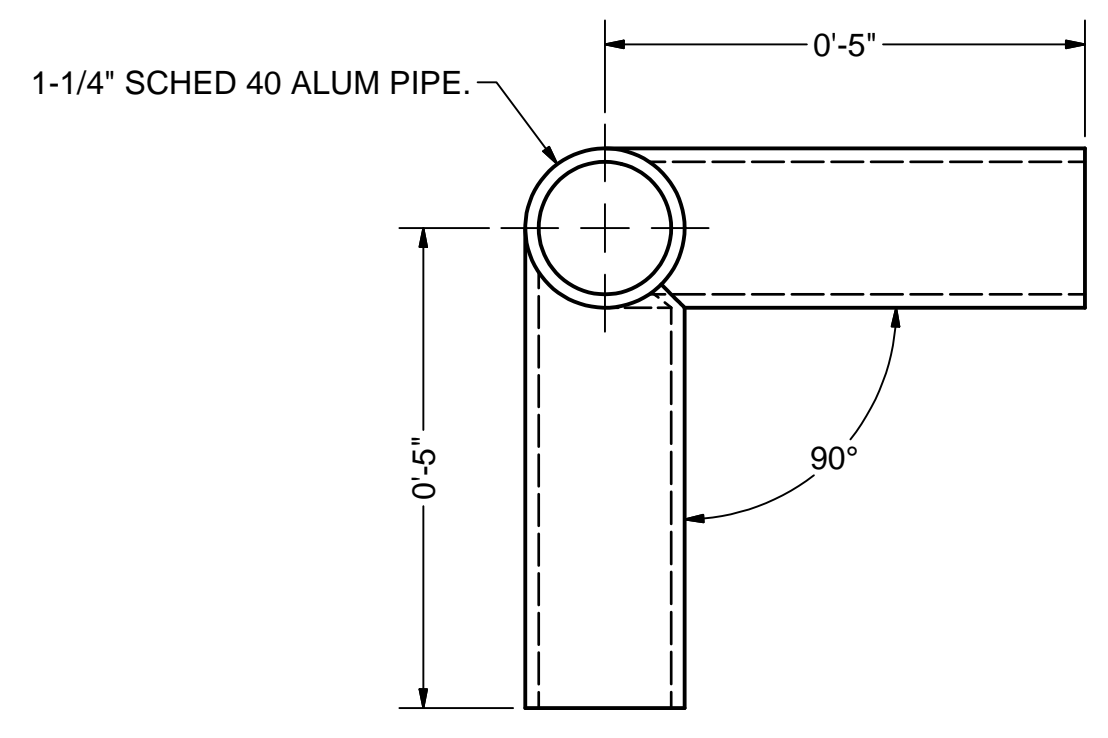

1 PIPE CORNER - PLAN
 HALF SIZE
 2 REQUIRED

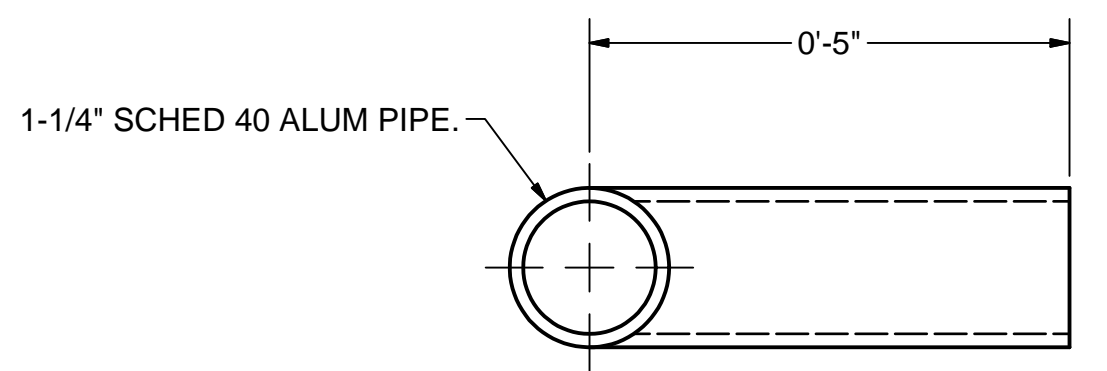

3 PIPE DS - PLAN
 HALF SIZE
 2 REQUIRED

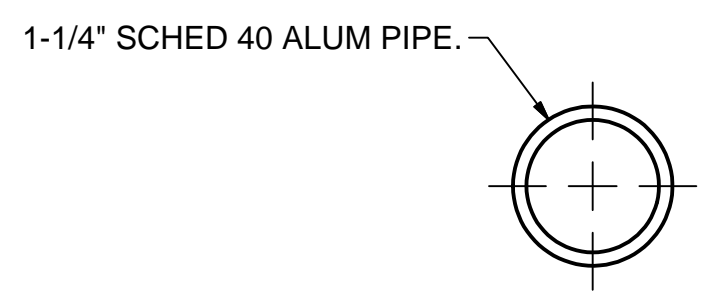

5 RAILING - ELEV
 HALF SIZE
 3 REQUIRED

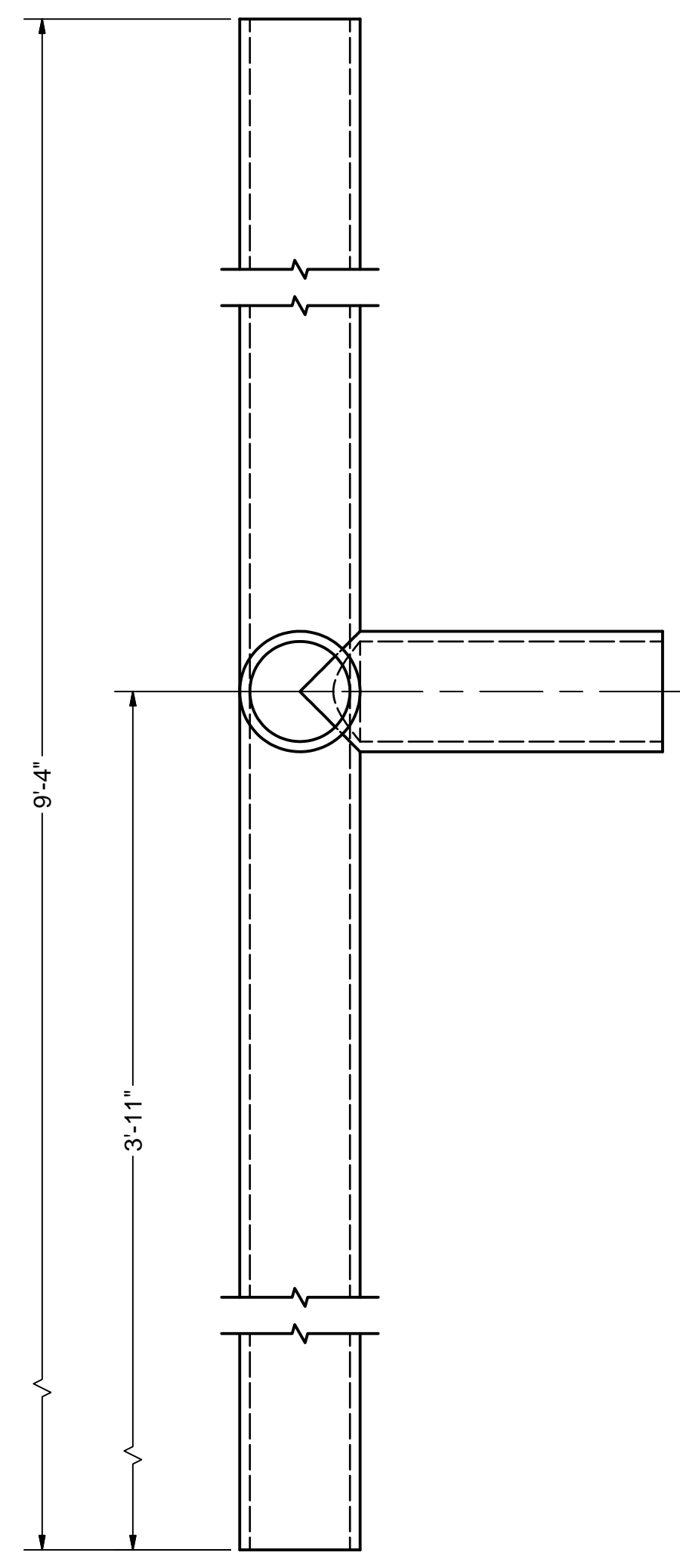

2 PIPE CORNER - ELEV
 HALF SIZE
 2 REQUIRED

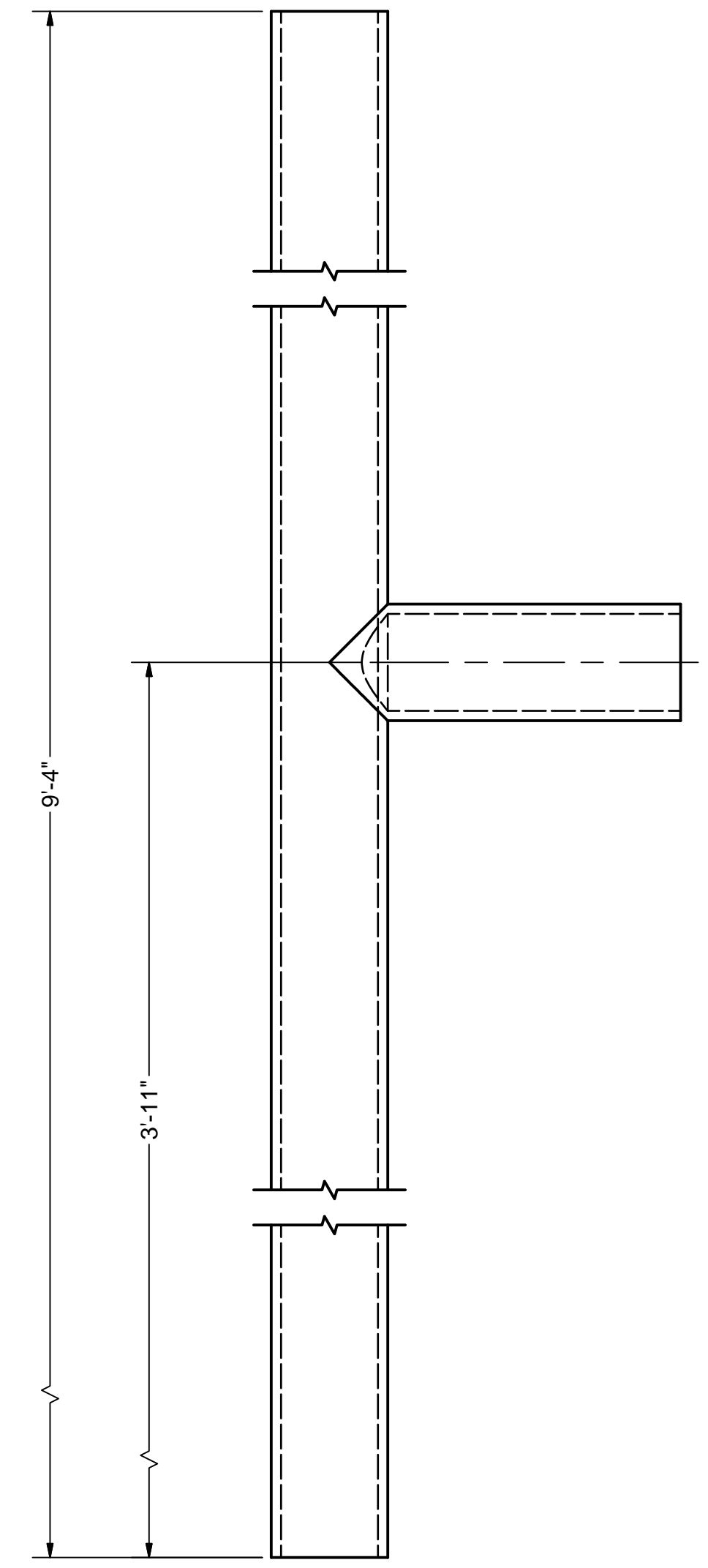

4 PIPE DS - ELEV
 HALF SIZE
 2 REQUIRED

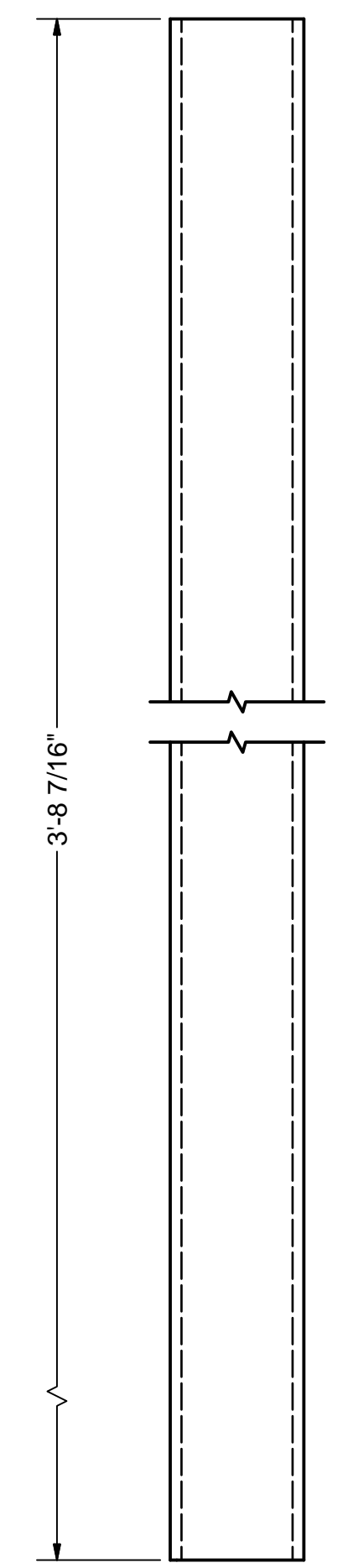

6 RAILING - PLAN
 HALF SIZE
 3 REQUIRED

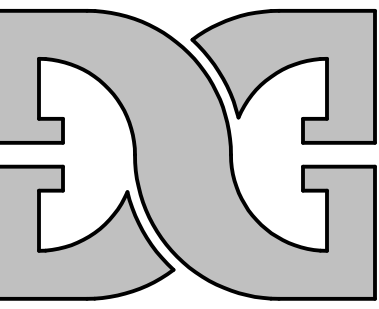

DIMENSIONAL GRAPHICS
 PHONE & FAX (650) 342-5724
 kenny@dgflow.com
 www.dgflow.com
 MATERIAL CALLOUTS ARE TO CLARIFY THE DESIGN INTENT. ALL DESIGN CONCEPTS AND MATERIALS MUST BE VERIFIED BY A LICENSED ENGINEER.

**PAGODA METAL PARTS
 SAN FRANCISCO OPERA
 MAGIC FLUTE 2012**

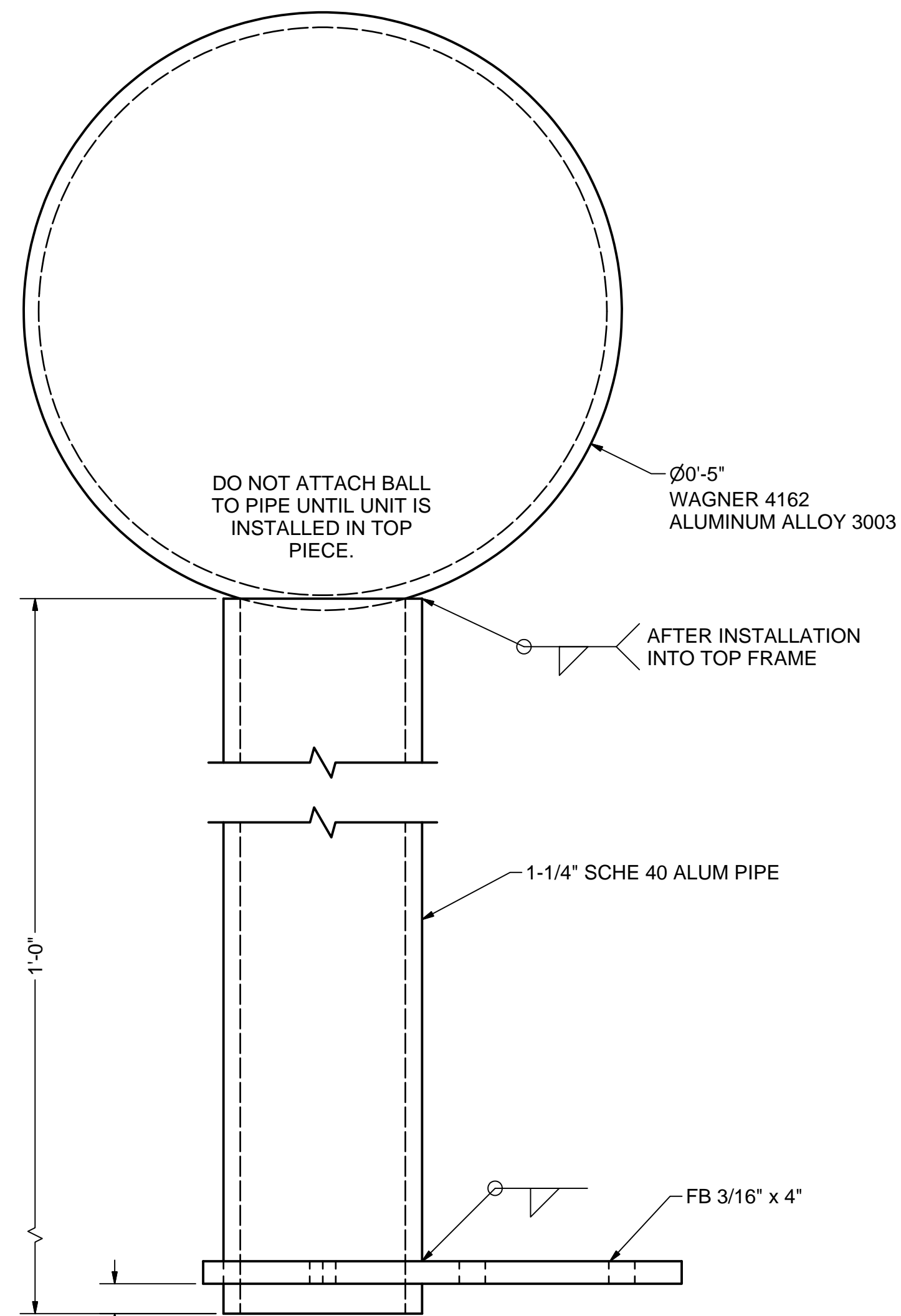

1 POLE CAP - ELEV
 FULL SIZE
 4 REQUIRED

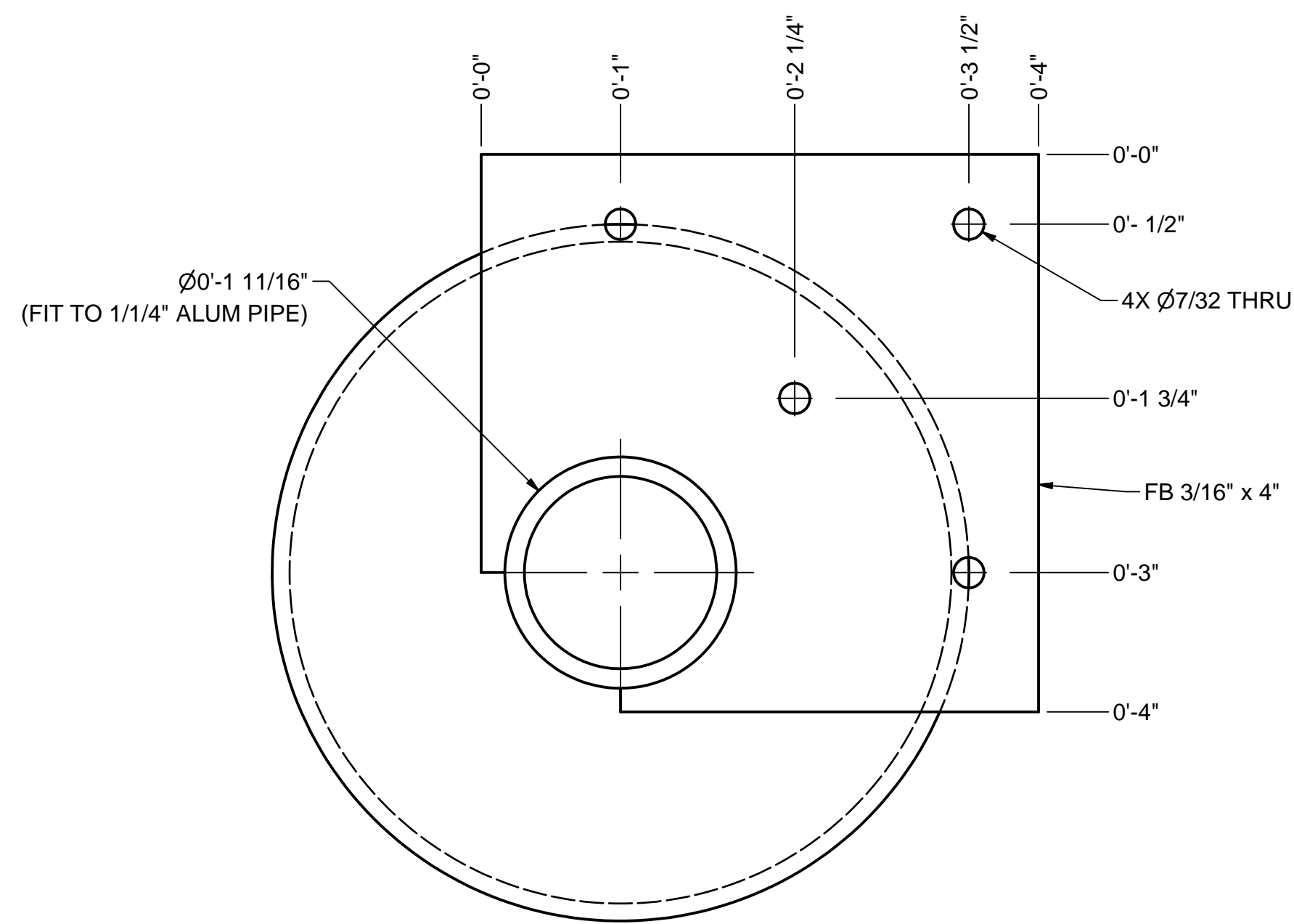

2 POLE CAP - BOTTOM
 FULL SIZE
 4 REQUIRED

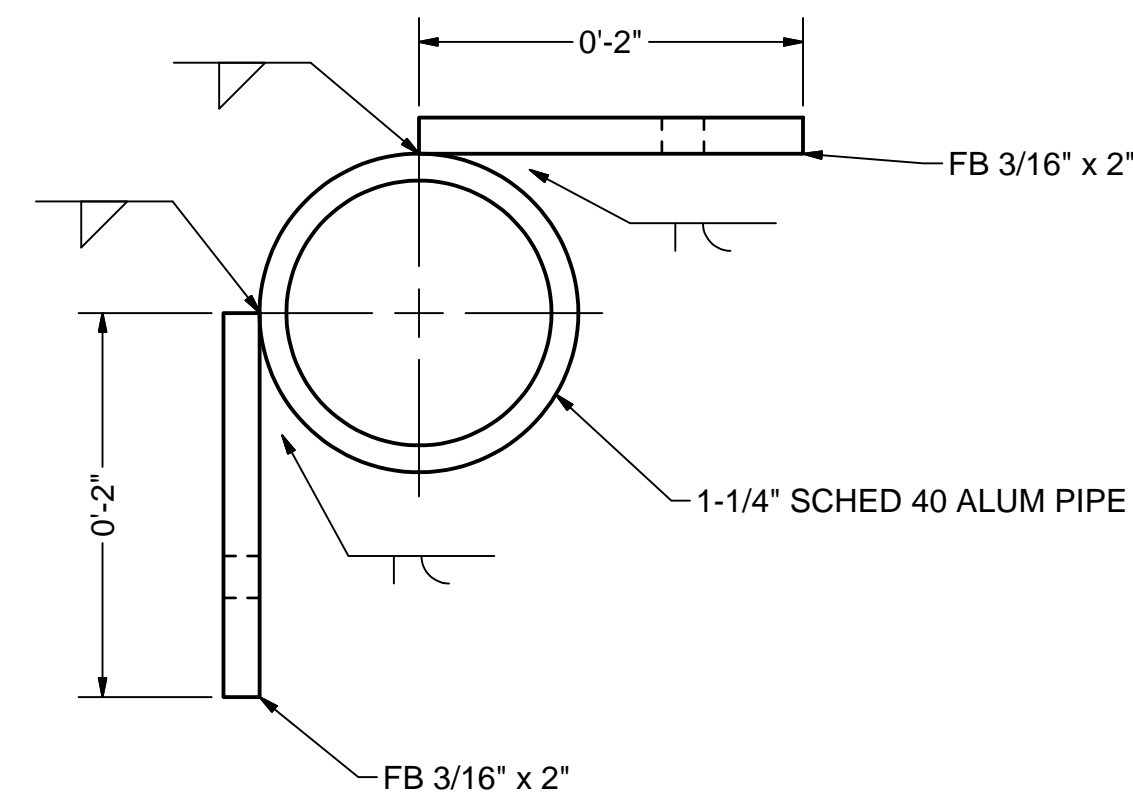

3 POLE ANCHOR - PLAN
 FULL SIZE
 4 REQUIRED

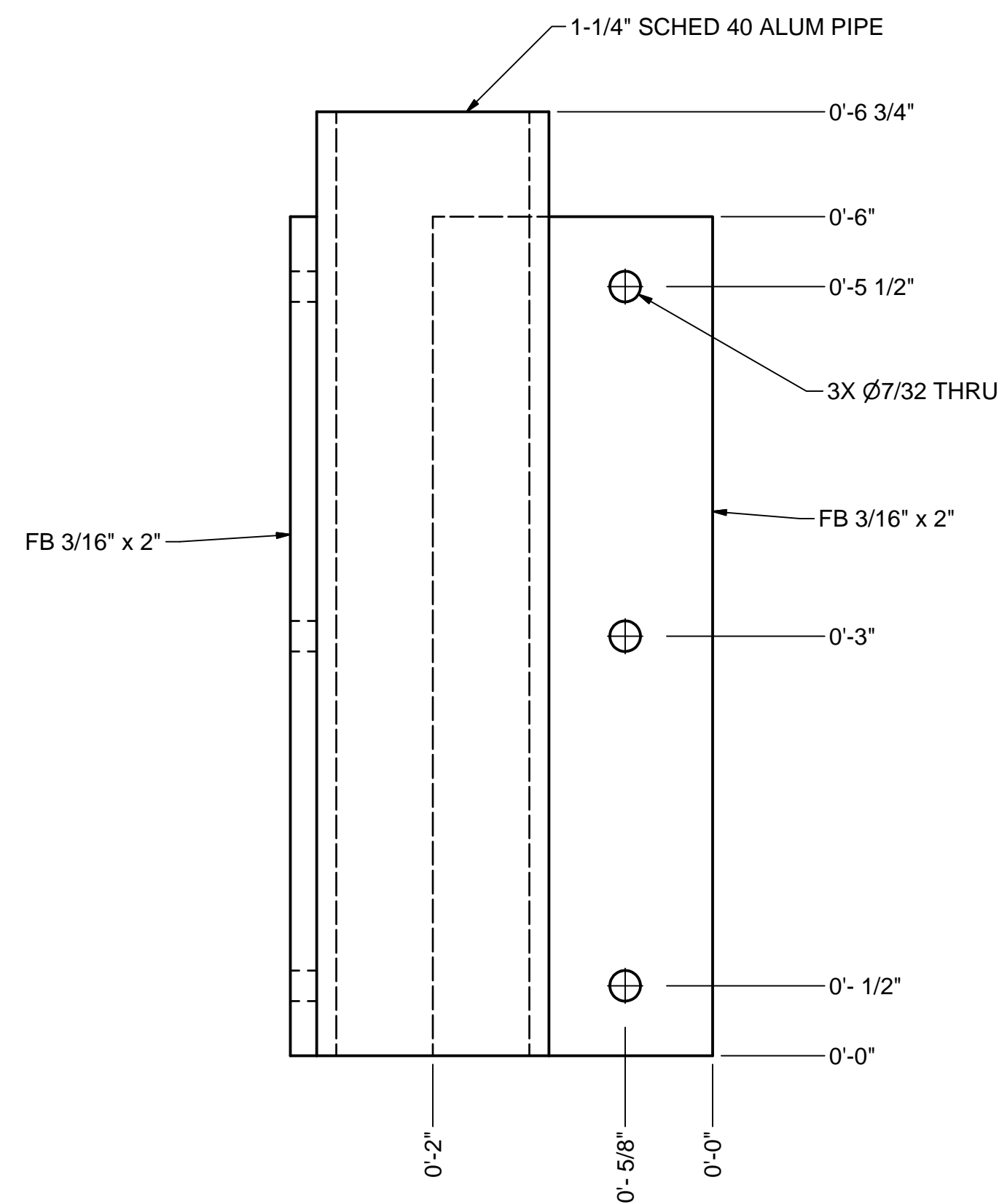

4 POLE ANCHOR - ELEV
 FULL SIZE
 4 REQUIRED

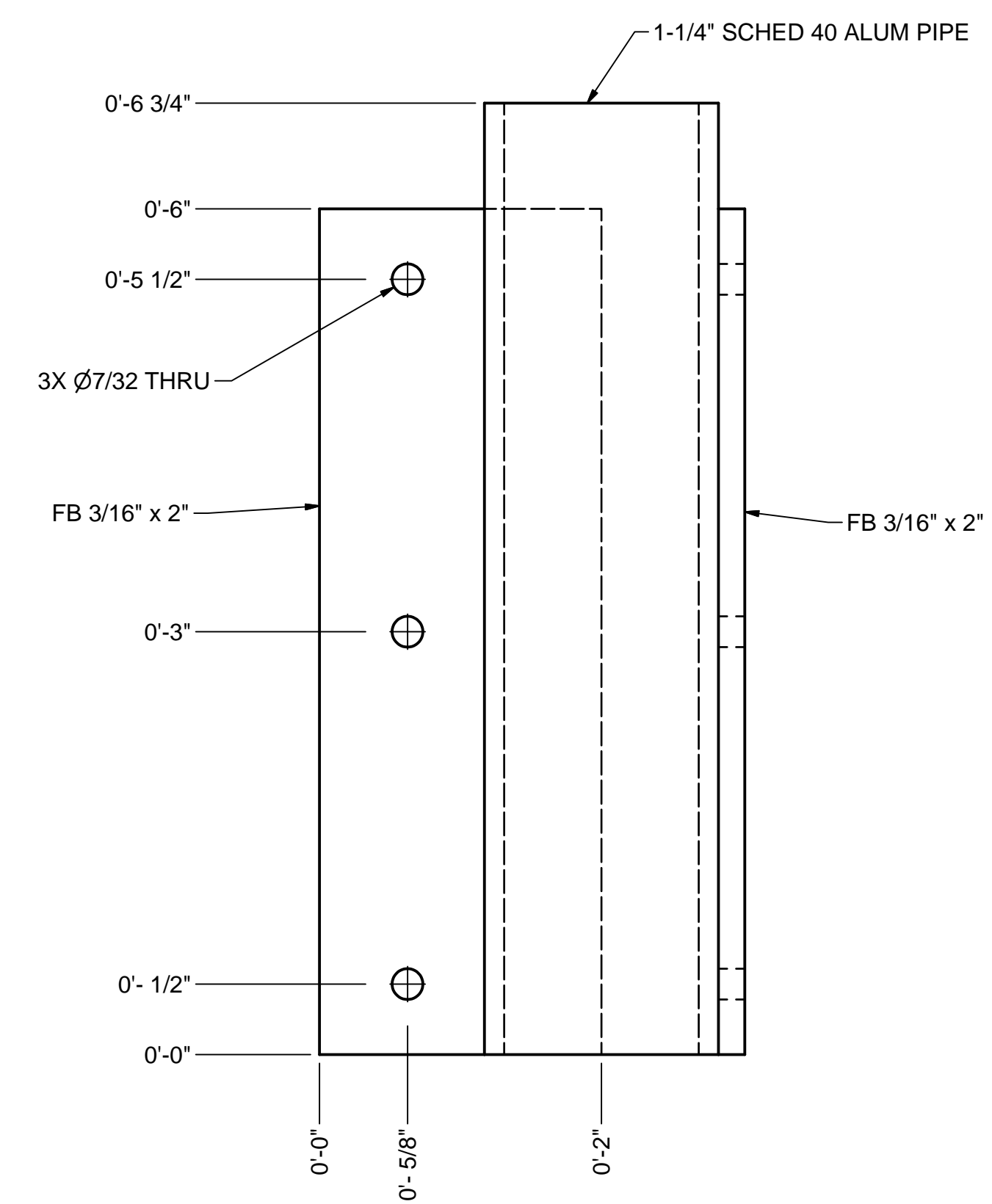

5 POLE ANCHOR - SIDE
 FULL SIZE
 4 REQUIRED

REFERENCED	
FROM	TO

JOB ID: _____
 DRAWN BY: **Ken Sly**
 APPROVED BY: _____
 ORIGINAL DATE: **2/8/2012**
 DUE DATE: _____
 SCALE: **FULL SIZE**
P7
 LATEST REVISION: _____

Parts List			
ITEM	QTY	PART NUMBER	DESCRIPTION
1	1	Snake B1 assm	SHEET SB2 VIEWS 1-4
2	1	Snake B2 assm	SHEET SB2 VIEWS 5-8
3	1	Snake Pivot Pin B1-2	SHEET SP8 VIEWS 1-2
4	1	Snake B3 assm	SHEET SB3 VIEWS 1-4
5	1	Snake Pivot Pin B2-3	SHEET SP8 VIEWS 1,3
6	1	Snake B4 assm	SHEET SB3 VIEWS 5-8
7	1	Snake Pivot Pin B3-4	SHEET SP8 VIEWS 1,4
8	1	Snake B5 assm	SHEET SB4 VIEWS 1-4
9	1	Snake Pivot Pin B4-5	SHEET SP8 VIEWS 1,5
10	1	Snake B6 assm	SHEET SB4 VIEWS 5-8
11	1	Snake Pivot Pin B5-6	SHEET SP8 VIEWS 1,6
12	1	Snake B7 assm	SHEET SB5 VIEWS 1-4
13	1	Snake Pivot Pin B6-7	SHEET SP8 VIEWS 1,7
14	1	Snake B8 assm	SHEET SB5 VIEWS 5-8
15	1	Snake Pivot Pin B7-8	SHEET SP8 VIEWS 1,8
16	1	Snake B9 assm	SHEET SB6 VIEWS 1-4
17	1	Snake Pivot Pin B8-9	SHEET SP8 VIEWS 1,9
18	1	Snake B10 assm	SHEET SB6 VIEWS 5-8
19	1	Snake Pivot Pin B9-10	SHEET SP9 VIEWS 1-2
20	1	Snake B11 assm	SHEET SB7 VIEWS 1-4
21	1	Snake Pivot Pin B10-11	SHEET SP9 VIEWS 1,3
22	1	Snake B12 assm	SHEET SB7 VIEWS 5-8
23	1	Snake Pivot Pin B11-12	SHEET SP9 VIEWS 1,4
24	4	Snake B13 assm	SHEET SB8 VIEWS 1-4
25	4	Snake Pivot Pin B12-13	SHEET SP9 VIEWS 1,5
26	1	Snake B14 assm	SHEET SB8 VIEWS 5-8
27	1	Snake Pivot Pin B13-14	SHEET SP9 VIEWS 1,6
28	1	Snake B15 assm	SHEET SB9 VIEWS 1-4
29	1	Snake Pivot Pin B14-15	SHEET SP9 VIEWS 1,7
30	1	Snake B16 assm	SHEET SB9 VIEWS 5-8
31	1	Snake Pivot Pin B15-16	SHEET SP9 VIEWS 1,8
32	1	Snake B17 assm	SHEET SB10 VIEWS 1-4
33	1	Snake Pivot Pin B16-17	SHEET SP9 VIEWS 1,9
34	1	Snake B18 assm	SHEET SB10 VIEWS 5-8
35	1	Snake Pivot Pin B17-18	SHEET SP10 VIEWS 1,2
36	1	Snake B19 assm	SHEET SB11 VIEWS 1-4
37	1	Snake Pivot Pin B18-19	SHEET SP10 VIEWS 1,3
38	1	Snake B20 assm	SHEET SB11 VIEWS 5-8
39	1	Snake Pivot Pin B19-20	SHEET SP10 VIEWS 1,4
40	1	Snake B21 assm	SHEET SB12 VIEWS 1-4
41	1	Snake Pivot Pin B20-21	SHEET SP10 VIEWS 1,5
42	1	Snake B22 assm	SHEET SB12 VIEWS 5-8
43	1	Snake Pivot Pin B21-22	SHEET SP10 VIEWS 1,6
44	1	Snake B23 assm	SHEET SB13 VIEWS 1-4
45	1	Snake Pivot Pin B22-23	SHEET SP10 VIEWS 1,7

NOTES:
 THIS SKELETAL FRAME NEEDS TO BE COVERED WITH A PLASTIC "SLIP SKIN" TO SUPPORT FINAL SCENIC SKIN. WE WILL DISCUSS REQUIREMENTS OF "SLIP SKIN" AFTER THE FRAME IS CONSTRUCTED.

HANDLES FOR PUPPETEERS NEED TO BE ADDED. WE CAN DECIDE BEST LOCATIONS AFTER SKELETON IS ASSEMBLED.

SOME OF THE CONNECTING PINS MAY NEED TO BE REMOVED QUICKLY FOR PRODUCTION REASONS. WE CAN DISCUSS METHODS AND LOCATIONS AFTER SKELETON IS ASSEMBLED.

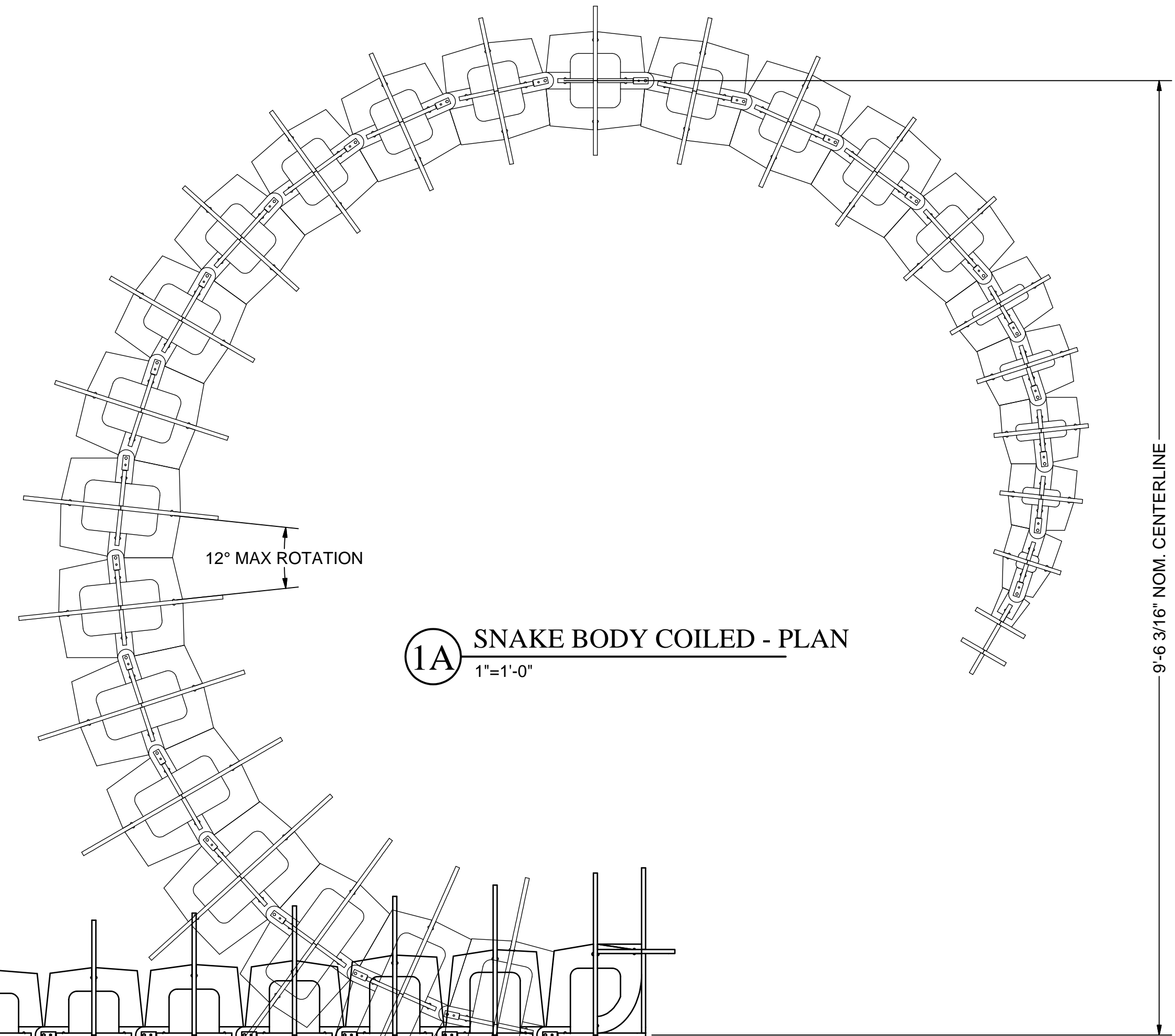

1A SNAKE BODY COILED - PLAN
 1"=1'-0"

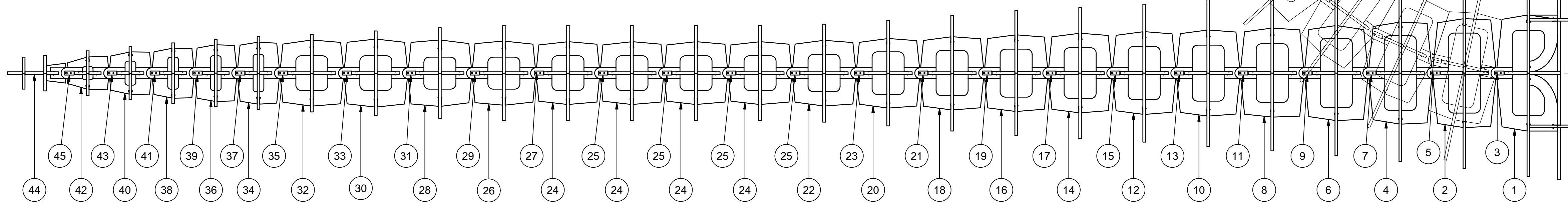

1 SNAKE BODY FRAME - PLAN
 1"=1'-0"
 1 ASSEMBLY REQUIRED

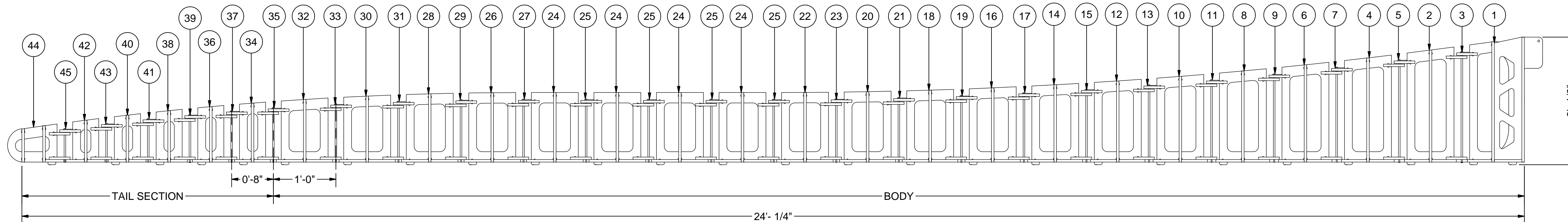

2 SNAKE BODE FRAME - ELEV
 1"=1'-0"
 1 ASSEMBLY REQUIRED

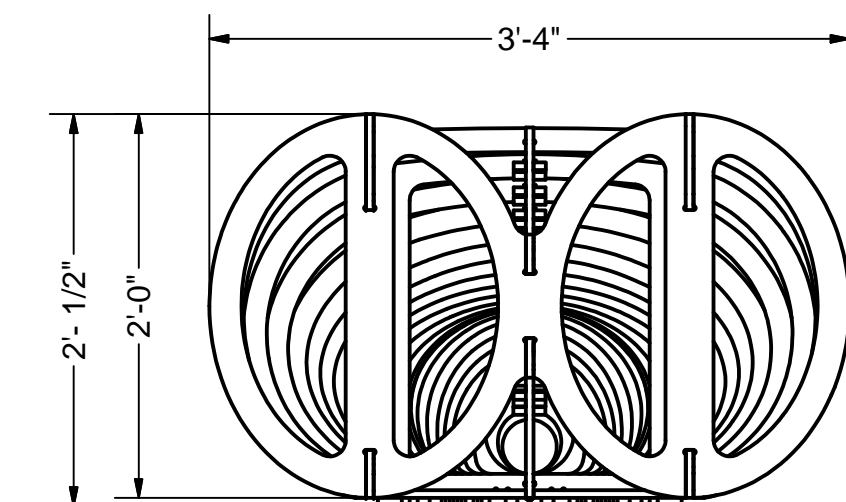

3 SNAKE BODY - NECK END
 1"=1'-0"

REFERENCED	
FROM	TO

JOB ID:	
DRAWN BY:	Ken Sly
APPROVED BY:	
ORIGINAL DATE:	1/26/2012
DUE DATE:	
SCALE:	1"=1'-0"
SB1	
LATEST REVISION	

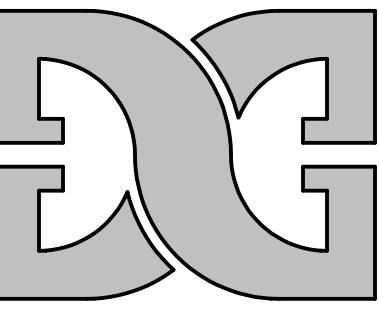

DIMENSIONAL GRAPHICS
 PHONE & FAX (650) 342-5724
 kenny@dgflow.com
 www.dgflow.com

MATERIAL CALLOUTS ARE TO CLARIFY THE DESIGN INTENT. ALL DESIGN CONCEPTS AND MATERIALS MUST BE VERIFIED BY A LICENSED ENGINEER.

Parts List			
ITEM	QTY	PART NUMBER	DESCRIPTION
1	1	Snake B1 B	SHEET SP1 VIEW 1
2	1	Snake B1 S	SHEET SP3 VIEW 1
3	2	Snake B1 R	SHEET SP5 VIEW 2
4	1	Snake Tab Hole	SHEET SP7 VIEW 1
5	1	Snake B1 F	SHEET SP5 VIEW 1
6	2	Snake B1 S1	SHEET SP3 VIEW 2
7	4	Snake Slider	SHEET SP7 VIEW 3-4

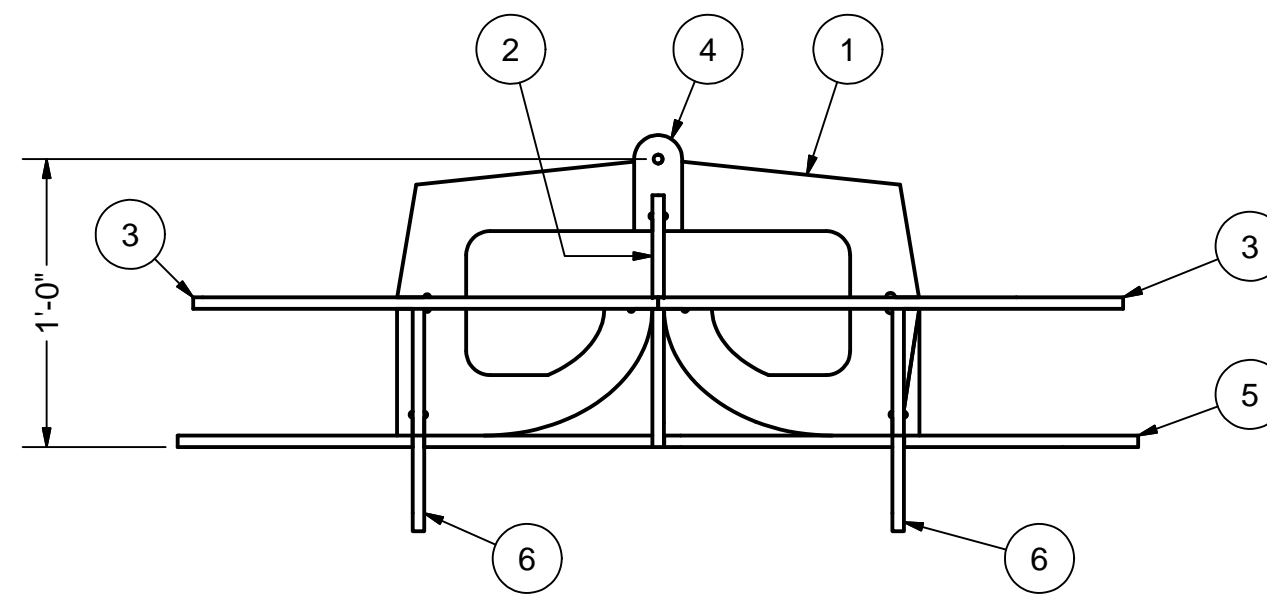

1 B1 FRAME - PLAN
 1-1/2"=1'-0"
 1 REQUIRED

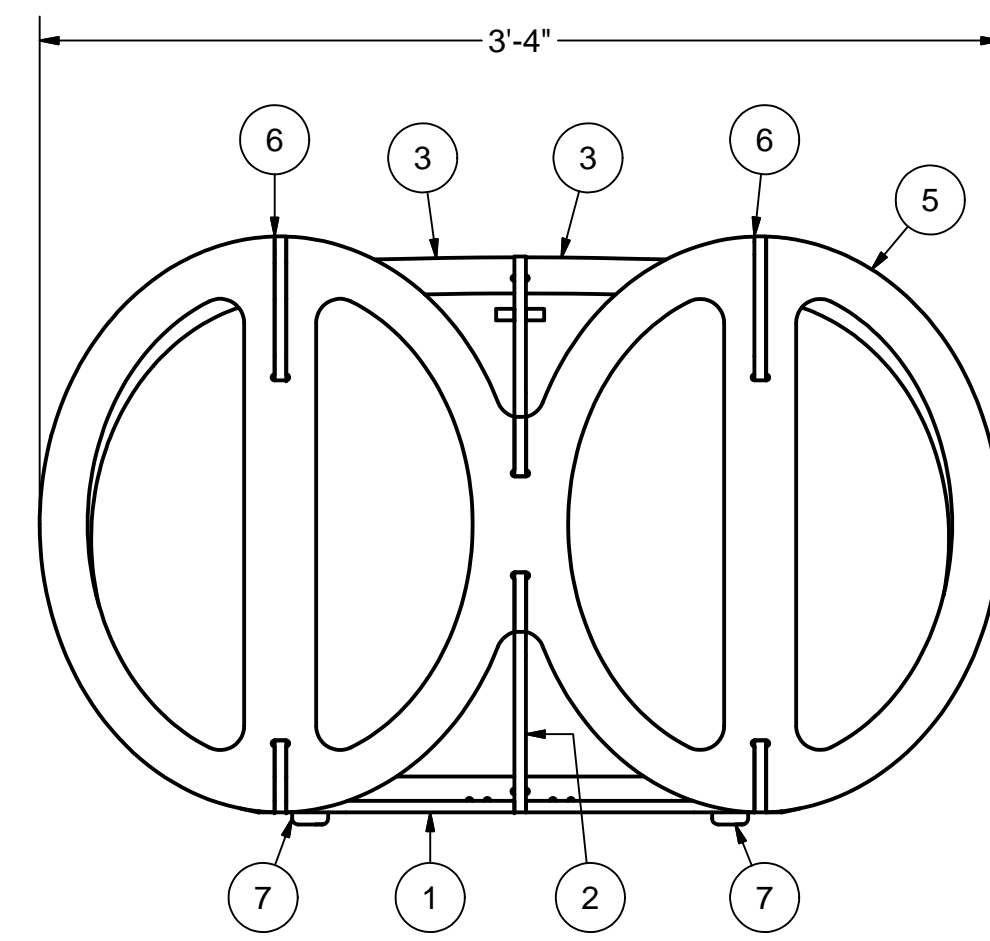

2 B1 FRAME - FACE
 1-1/2"=1'-0"
 1 REQUIRED

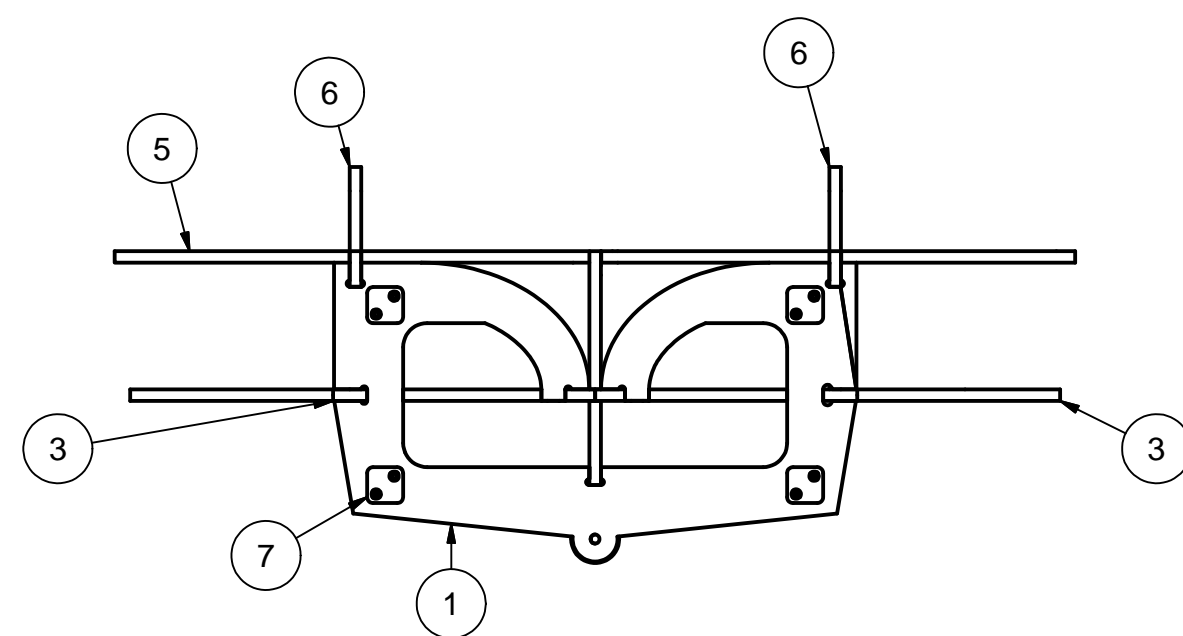

4 B1 FRAME - BOTTOM
 1-1/2"=1'-0"
 1 REQUIRED

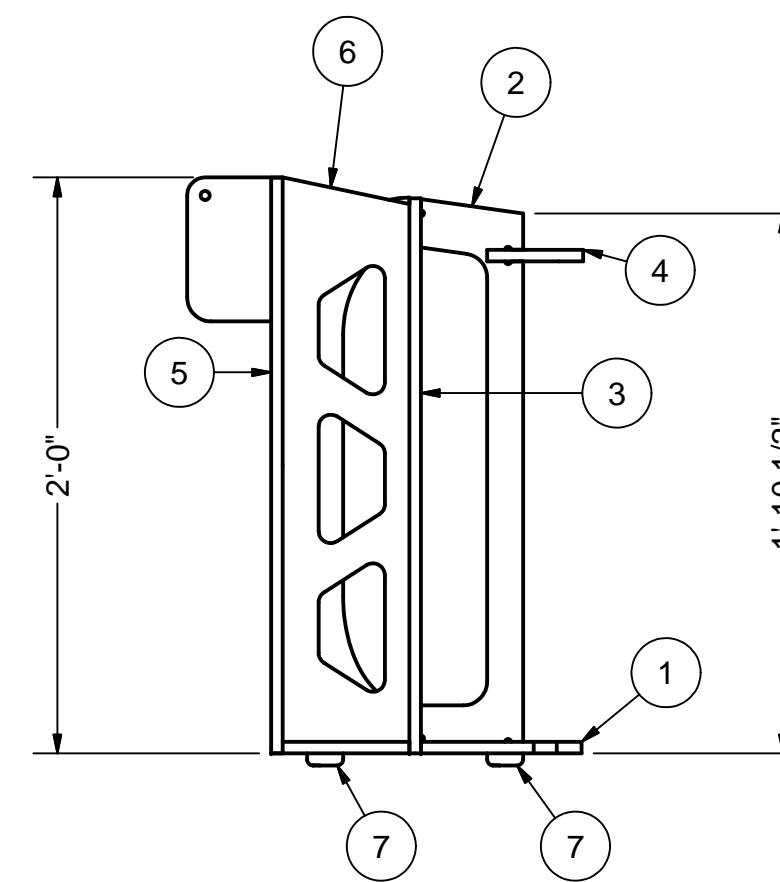

3 B1 FRAME - SIDE
 1-1/2"=1'-0"
 1 REQUIRED

Parts List			
ITEM	QTY	PART NUMBER	DESCRIPTION
8	1	Snake B2 B	SHEET SP1 VIEW 2
9	1	Snake B2 S	SHEET SP3 VIEW 3
10	1	Snake Tab Slot	SHEET SP7 VIEW 2
11	2	Snake Tab Hole	SHEET SP7 VIEW 1
12	2	Snake B2 R	SHEET SP5 VIEW 3
13	2	Snake Slider	SHEET SP7 VIEW 3-4

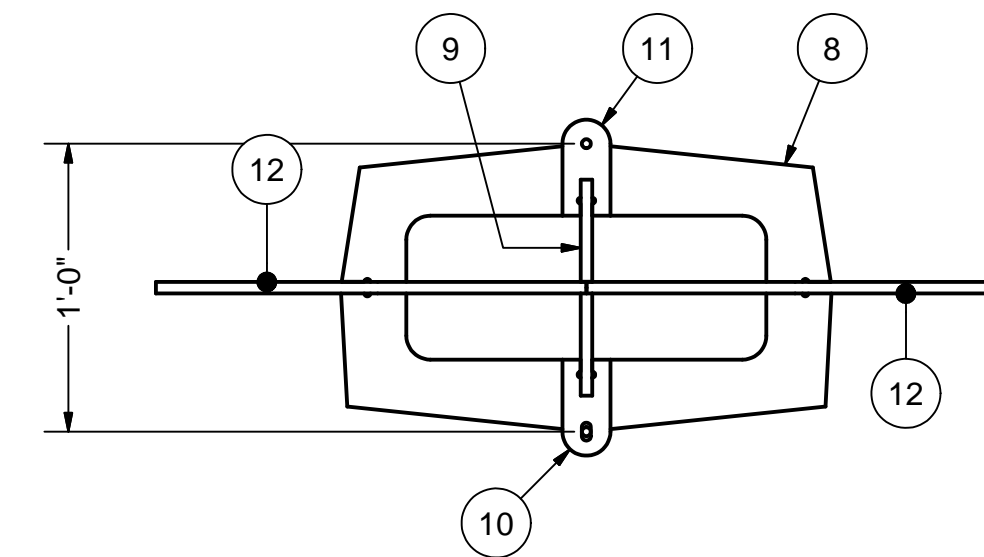

5 B2 FRAME - PLAN
 1-1/2"=1'-0"
 1 REQUIRED

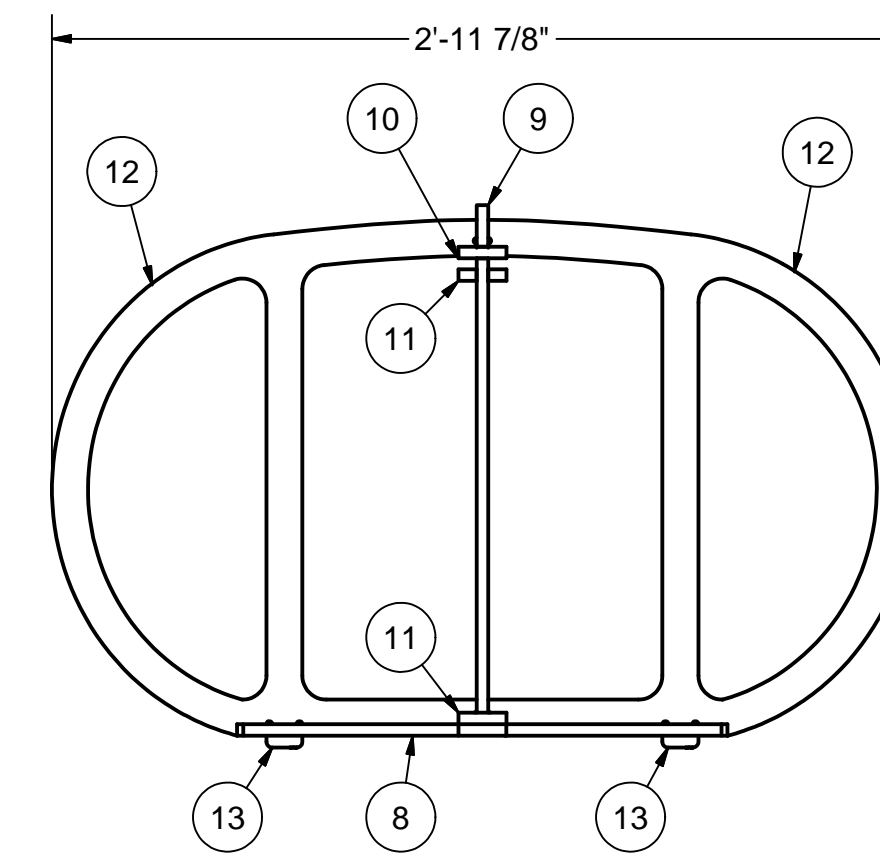

6 B2 FRAME - FACE
 1-1/2"=1'-0"
 1 REQUIRED

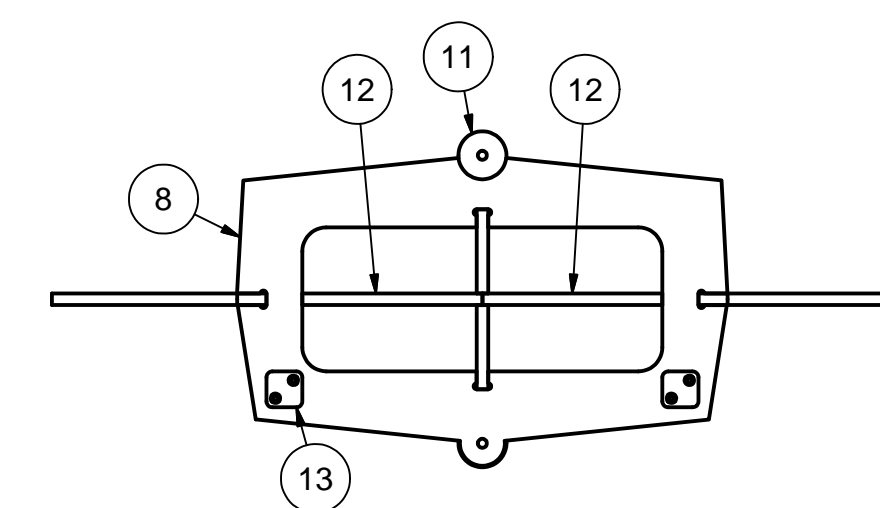

8 B2 FRAME - BOTTOM
 1-1/2"=1'-0"
 1 REQUIRED

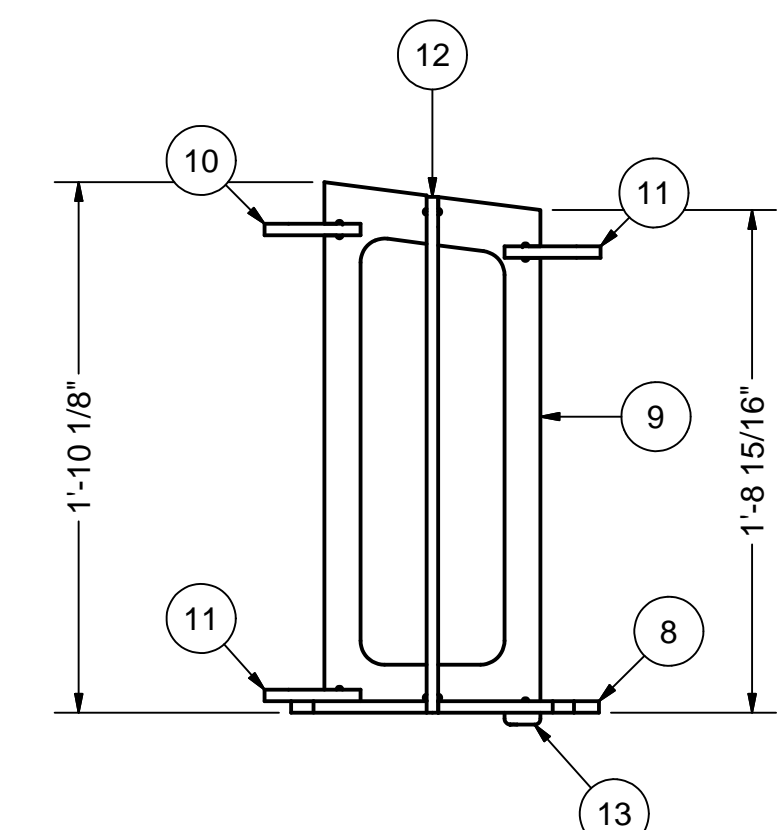

7 B2 FRAME - SIDE
 1-1/2"=1'-0"
 1 REQUIRED

SNAKE BODY PART LAYOUTS
 SAN FRANCISCO OPERA
 MAGIC FLUTE 2012

REFERENCED	
FROM	TO

JOB ID: _____
 DRAWN BY: Ken Sly
 APPROVED BY: _____
 ORIGINAL DATE: 1/27/2012
 DUE DATE: _____
 SCALE: 1-1/2"=1'-0"
SB2
 LATEST REVISION **A**

Parts List			
ITEM	QTY	PART NUMBER	DESCRIPTION
1	1	Snake B3 B	SHEET SP1 VIEW 3
2	1	Snake B3 S	SHEET SP3 VIEW 4
3	2	Snake B3 R	SHEET SP5 VIEW 4
4	2	Snake Tab Hole	SHEET SP7 VIEW 1
5	1	Snake Tab Slot	SHEET SP7 VIEW 2
6	2	Snake Slider	SHEET SP7 VIEW 3-4

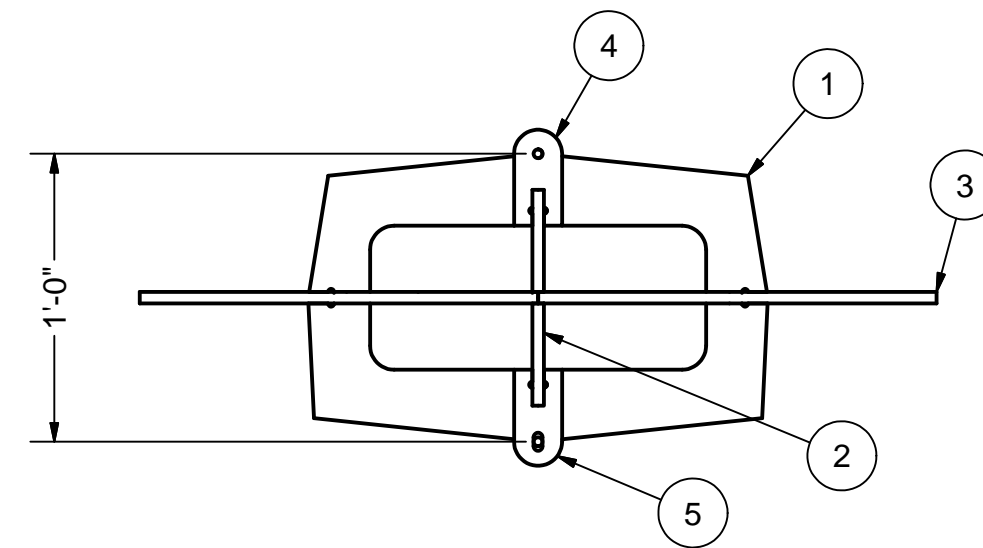

1 B3 FRAME - PLAN
1-1/2"=1'-0"
1 REQUIRED

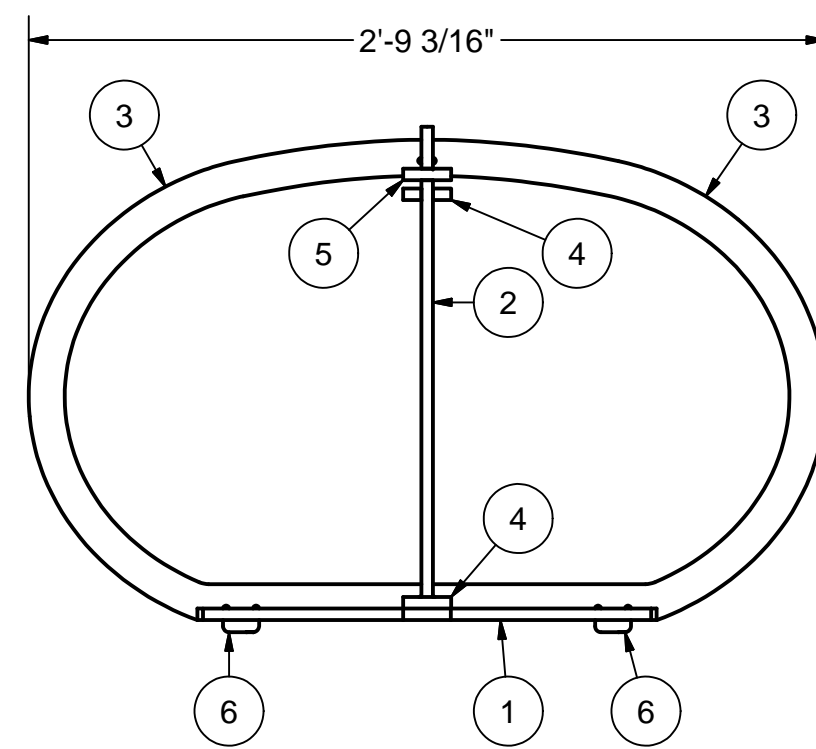

2 B3 FRAME - FACE
1-1/2"=1'-0"
1 REQUIRED

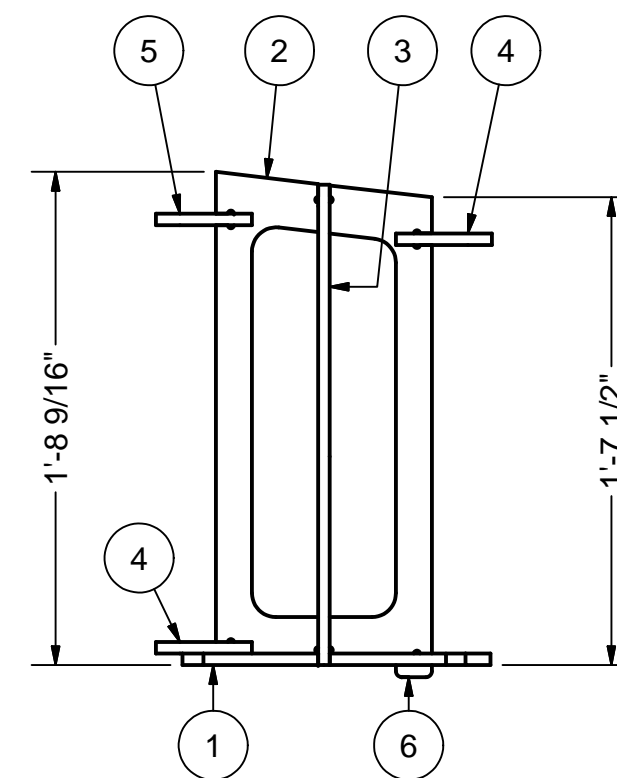

3 B3 FRAME - SIDE
1-1/2"=1'-0"
1 REQUIRED

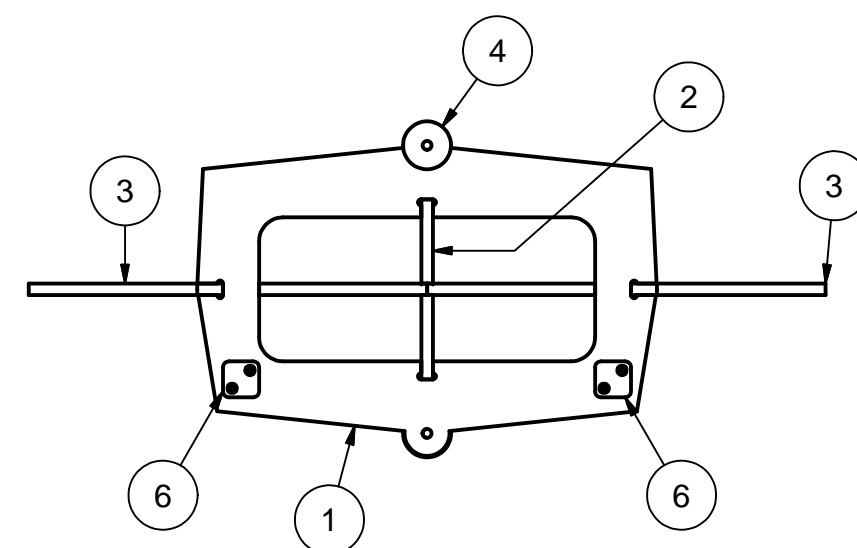

4 B3 FRAME - BOTTOM
1-1/2"=1'-0"
1 REQUIRED

Parts List			
ITEM	QTY	PART NUMBER	DESCRIPTION
7	2	Snake Tab Hole	SHEET SP7 VIEW 1
8	1	Snake Tab Slot	SHEET SP7 VIEW 2
9	2	Snake Slider	SHEET SP7 VIEW 3-4
10	1	Snake B4 B	SHEET SP1 VIEW 4
11	1	Snake B4 S	SHEET SP3 VIEW 5
12	2	Snake B4 R	SHEET SP5 VIEW 5

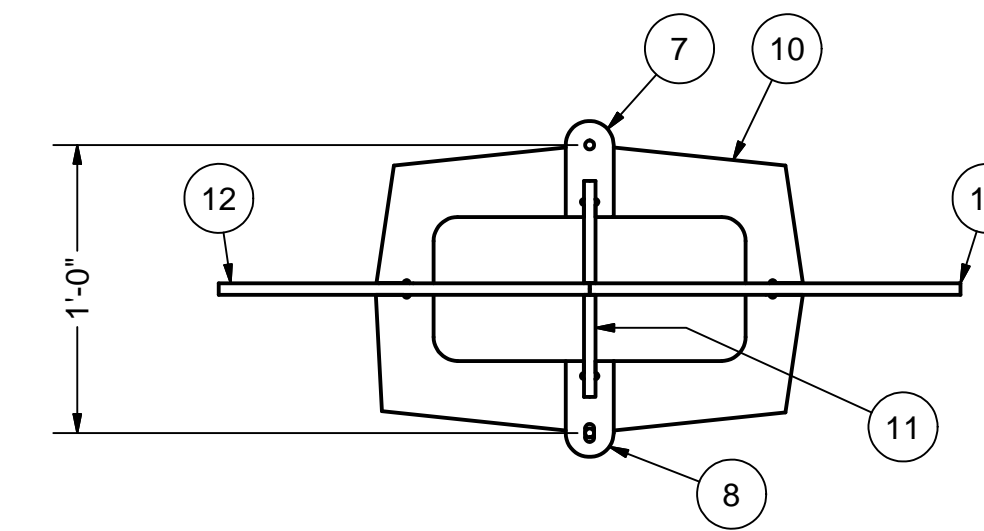

5 B4 FRAME - PLAN
1-1/2"=1'-0"
1 REQUIRED

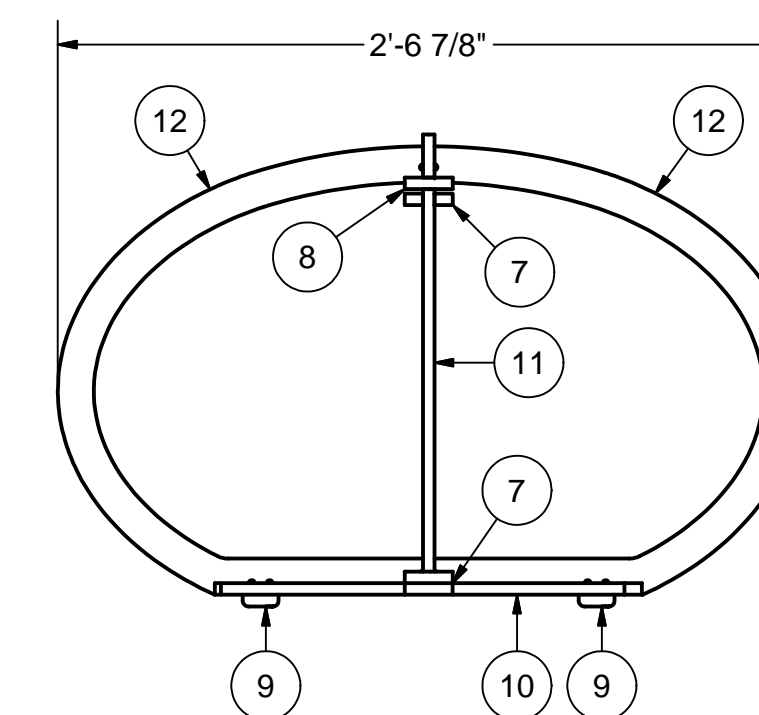

6 B4 FRAME - FACE
1-1/2"=1'-0"
1 REQUIRED

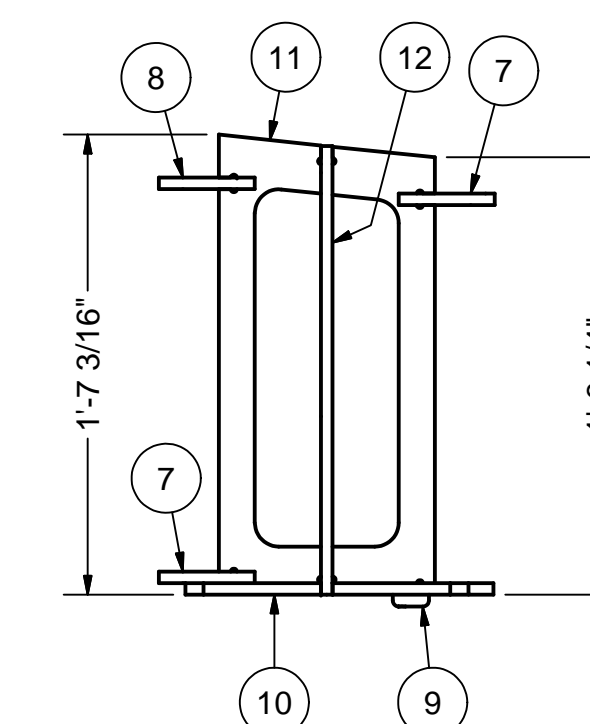

7 B4 FRAME - SIDE
1-1/2"=1'-0"
1 REQUIRED

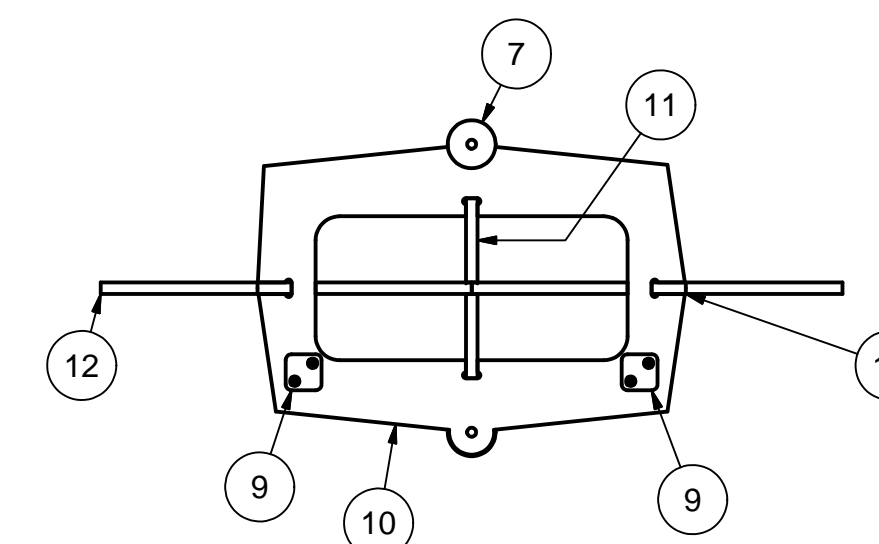

8 B4 FRAME - BOTTOM
1-1/2"=1'-0"
1 REQUIRED

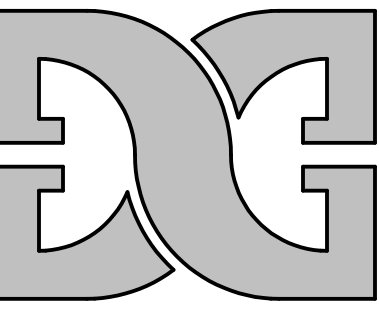

DIMENSIONAL GRAPHICS
PHONE & FAX (650) 342-5724
ken@dgflow.com
www.dgflow.com
MATERIAL CALLOUTS ARE TO CLARIFY THE DESIGN INTENT. ALL DESIGN CONCEPTS AND MATERIALS MUST BE VERIFIED BY A LICENSED ENGINEER.

SNAKE BODY PART LAYOUTS
SAN FRANCISCO OPERA
MAGIC FLUTE 2012

REFERENCED	
FROM	TO

JOB ID: _____
DRAWN BY: Ken Sly
APPROVED BY: _____
ORIGINAL DATE: 1/30/2012
DUE DATE: _____
SCALE: 1-1/2"=1'-0"

SB3
LATEST REVISION **A**

Parts List			
ITEM	QTY	PART NUMBER	DESCRIPTION
1	1	Snake B7 B	SHEET SP1 VIEW 7
2	1	Snake B7 S	SHEET SP3 VIEW 8
3	2	Snake B7 R	SHEET SP5 VIEW 8
4	2	Snake Tab Hole	SHEET SP7 VIEW 1
5	1	Snake Tab Slot	SHEET SP7 VIEW 2
6	2	Snake Slider	SHEET SP7 VIEW 3-4

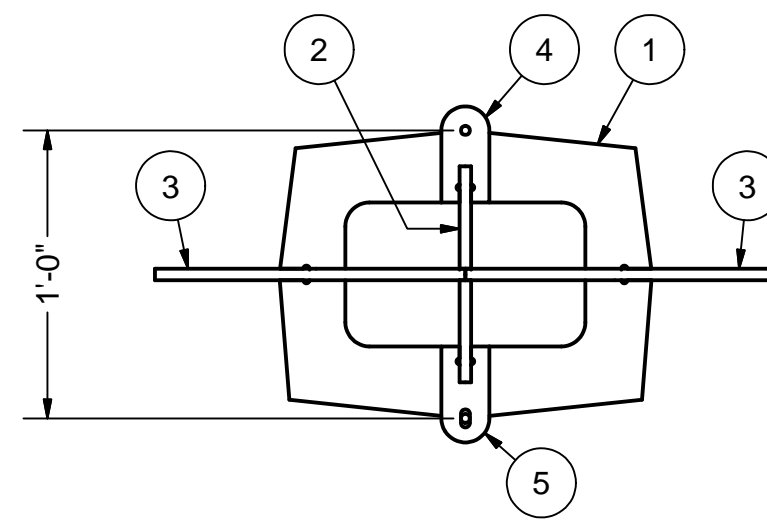

1 B7 FRAME - PLAN
1-1/2"=1'-0"
1 REQUIRED

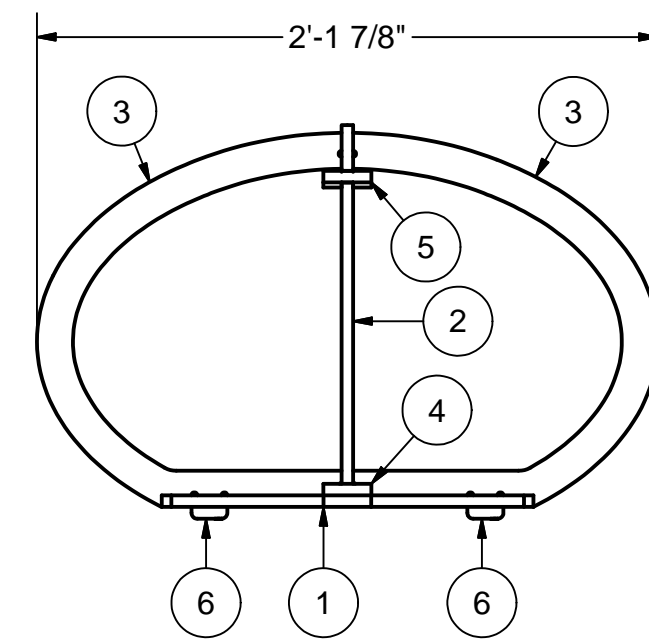

2 B7 FRAME - FACE
1-1/2"=1'-0"
1 REQUIRED

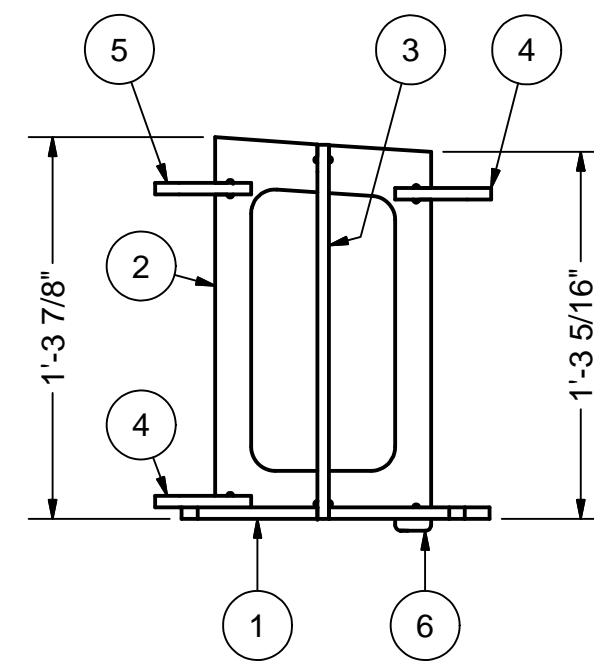

3 B7 FRAME - SIDE
1-1/2"=1'-0"
1 REQUIRED

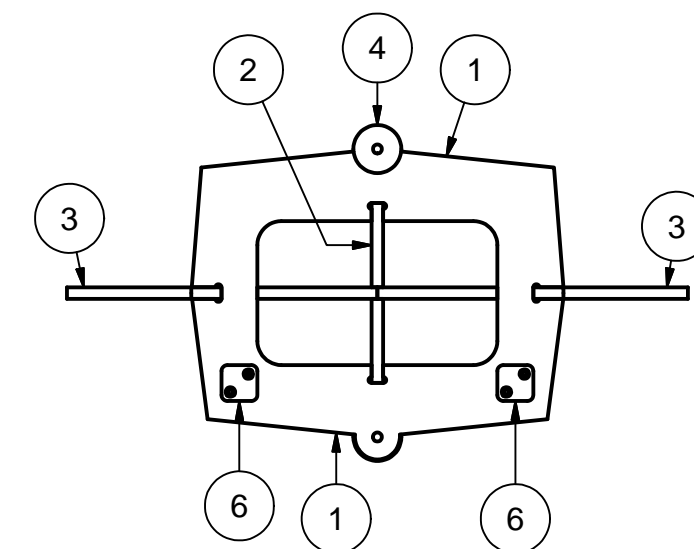

4 B7 FRAME - BOTTOM
1-1/2"=1'-0"
1 REQUIRED

Parts List			
ITEM	QTY	PART NUMBER	DESCRIPTION
7	1	Snake B8 B	SHEET SP1 VIEW 8
8	1	Snake B8 S	SHEET SP3 VIEW 9
9	2	Snake B8 R	SHEET SP5 VIEW 9
10	2	Snake Tab Hole	SHEET SP7 VIEW 1
11	1	Snake Tab Slot	SHEET SP7 VIEW 2
12	2	Snake Slider	SHEET SP7 VIEW 3-4

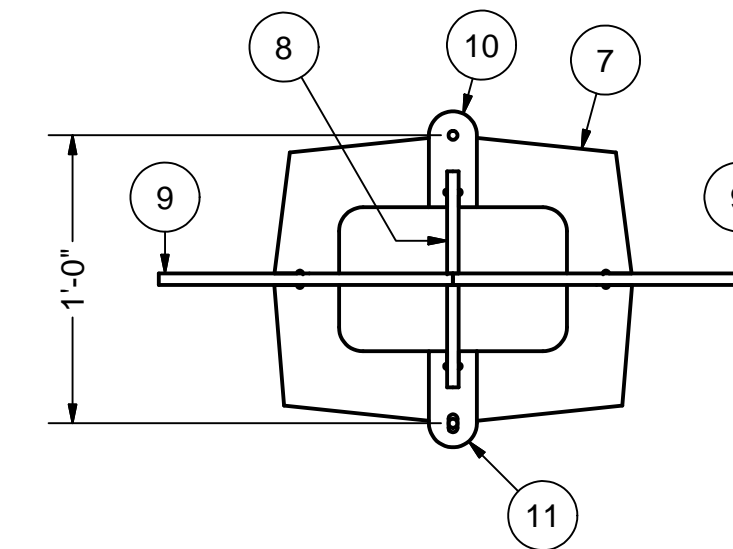

5 B8 FRAME - PLAN
1-1/2"=1'-0"
1 REQUIRED

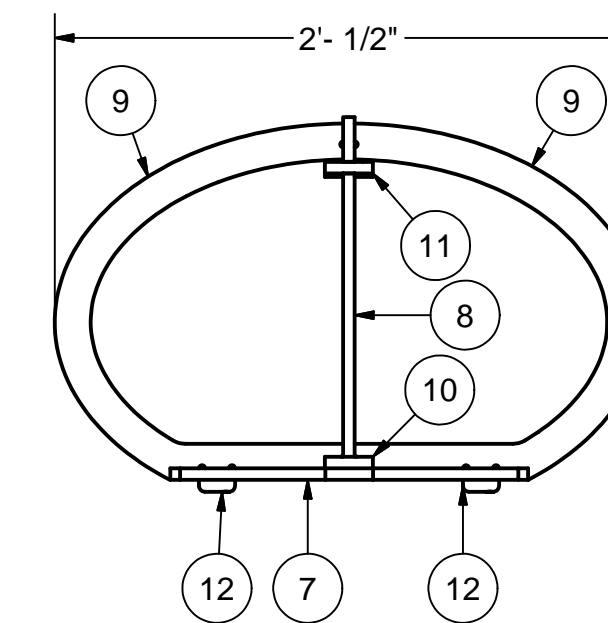

6 B8 FRAME - FACE
1-1/2"=1'-0"
1 REQUIRED

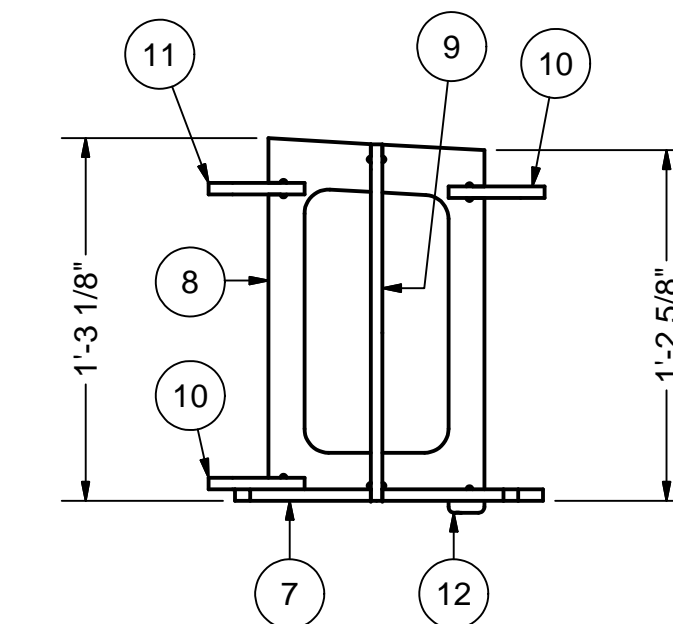

7 B8 FRAME - SIDE
1-1/2"=1'-0"
1 REQUIRED

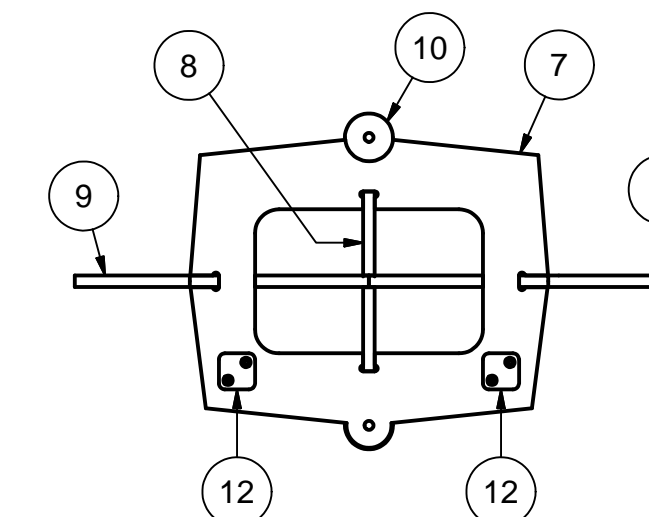

8 B8 FRAME - BOTTOM
1-1/2"=1'-0"
1 REQUIRED

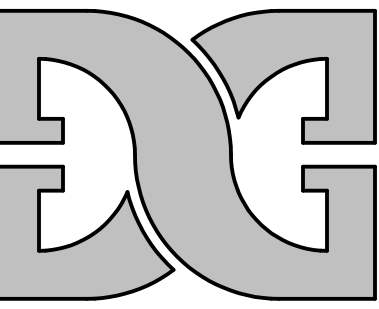

DIMENSIONAL GRAPHICS
PHONE & FAX (650) 342-5724
ken@dgflow.com
www.dgflow.com
MATERIAL CALLOUTS ARE TO CLARIFY THE DESIGN INTENT. ALL DESIGN CONCEPTS AND MATERIALS MUST BE VERIFIED BY A LICENSED ENGINEER.

SNAKE BODY PART LAYOUTS
SAN FRANCISCO OPERA
MAGIC FLUTE 2012

REFERENCED	
FROM	TO

JOB ID: _____
DRAWN BY: Ken Sly
APPROVED BY: _____
ORIGINAL DATE: 1/30/2012
DUE DATE: _____
SCALE: 1-1/2"=1'-0"

SB5
LATEST REVISION **A**

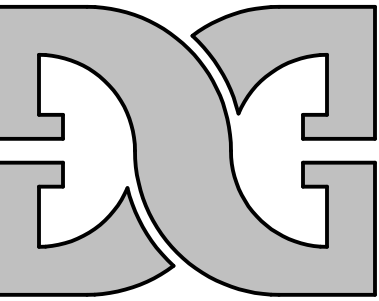

**DIMENSIONAL
GRAPHICS**

PHONE & FAX (650) 342-5724
ken@diglow.com
www.diglow.com
MATERIAL CALLOUTS ARE TO CLARIFY THE
DESIGN INTENT. ALL DESIGN CONCEPTS AND
MATERIALS MUST BE VERIFIED BY A
LICENSED ENGINEER.

Parts List			
ITEM	QTY	PART NUMBER	DESCRIPTION
1	1	Snake B9 B	SHEET SP1 VIEW 9
2	1	Snake B9 S	SHEET SP3 VIEW 10
3	2	Snake B9 R	SHEET SP5 VIEW 10
4	2	Snake Tab Hole	SHEET SP7 VIEW 1
5	1	Snake Tab Slot	SHEET SP7 VIEW 2
6	2	Snake Slider	SHEET SP7 VIEW 3-4

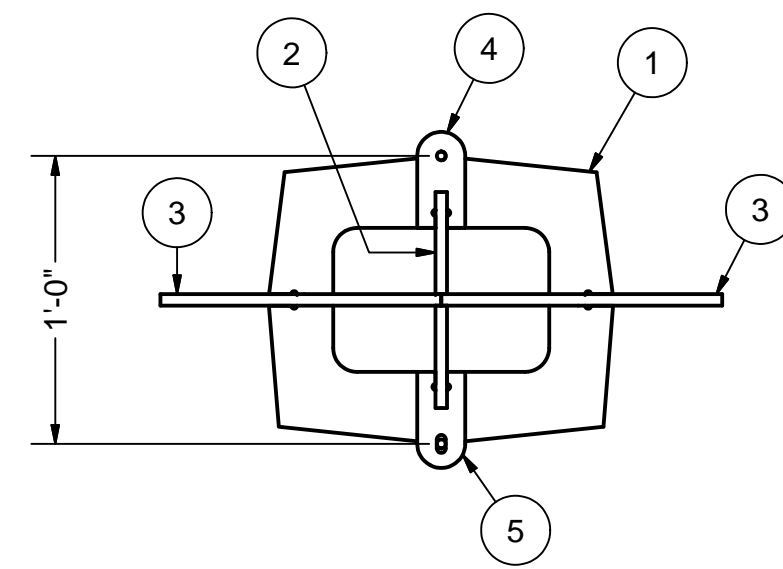

1 B9 FRAME - PLAN
1-1/2"=1'-0"
1 REQUIRED

Parts List			
ITEM	QTY	PART NUMBER	DESCRIPTION
7	1	Snake B10 B	SHEET SP1 VIEW 10
8	1	Snake B10 S	SHEET SP3 VIEW 11
9	2	Snake B10 R	SHEET SP5 VIEW 11
10	2	Snake Tab Hole	SHEET SP7 VIEW 1
11	1	Snake Tab Slot	SHEET SP7 VIEW 2
12	2	Snake Slider	SHEET SP7 VIEW 3-4

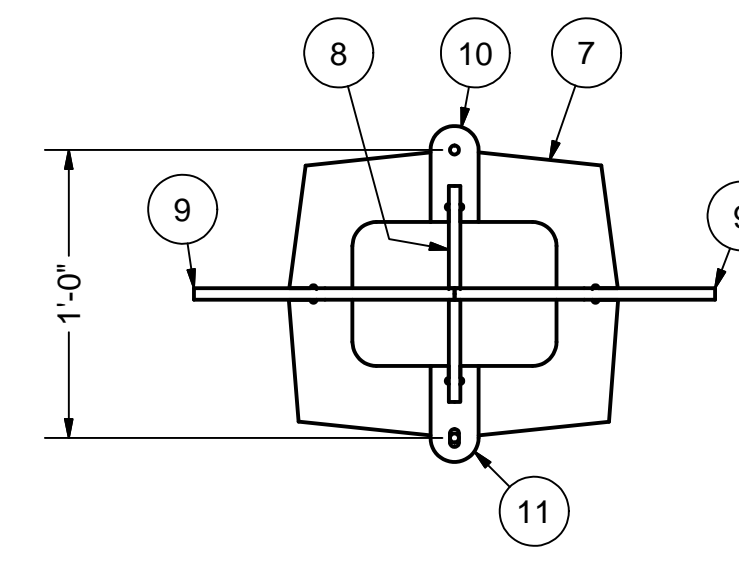

5 B10 FRAME - PLAN
1-1/2"=1'-0"
1 REQUIRED

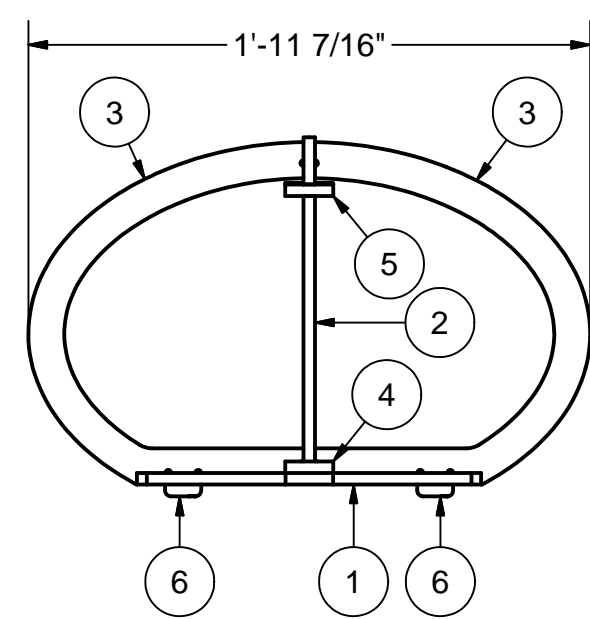

2 B9 FRAME - FACE
1-1/2"=1'-0"
1 REQUIRED

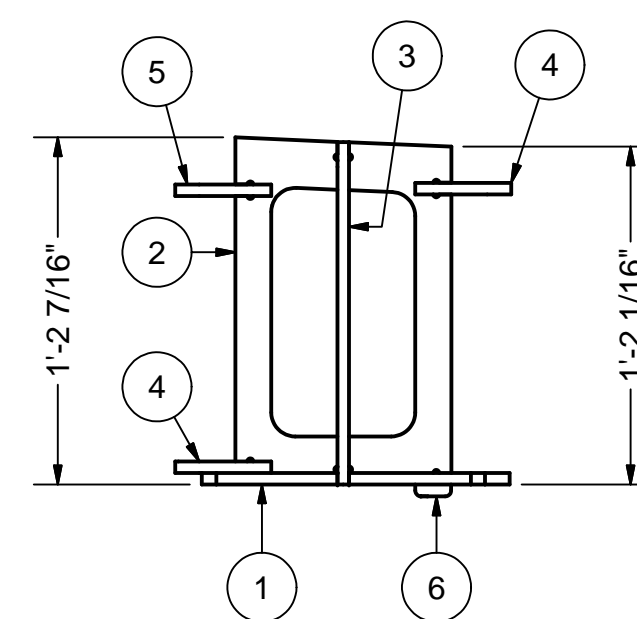

3 B9 FRAME - SIDE
1-1/2"=1'-0"
1 REQUIRED

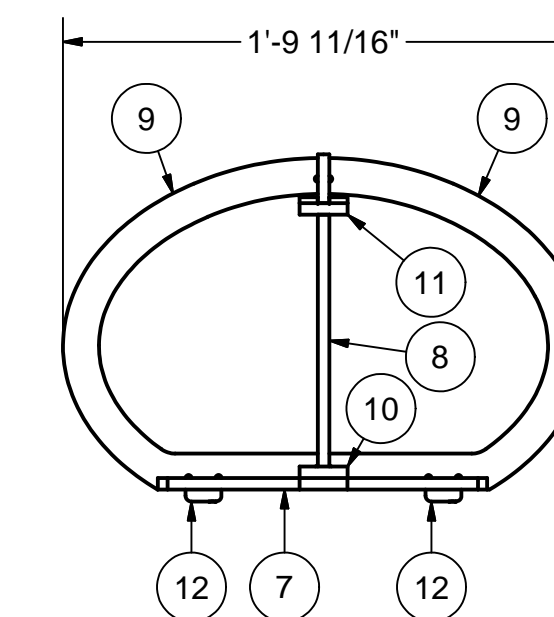

6 B10 FRAME - FACE
1-1/2"=1'-0"
1 REQUIRED

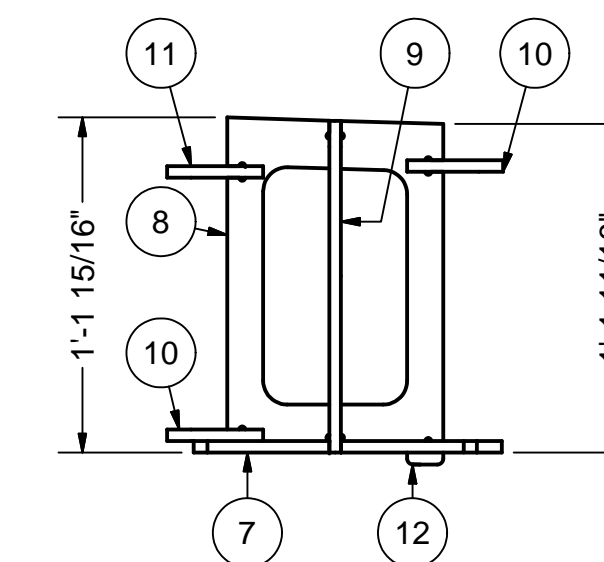

7 B10 FRAME - SIDE
1-1/2"=1'-0"
1 REQUIRED

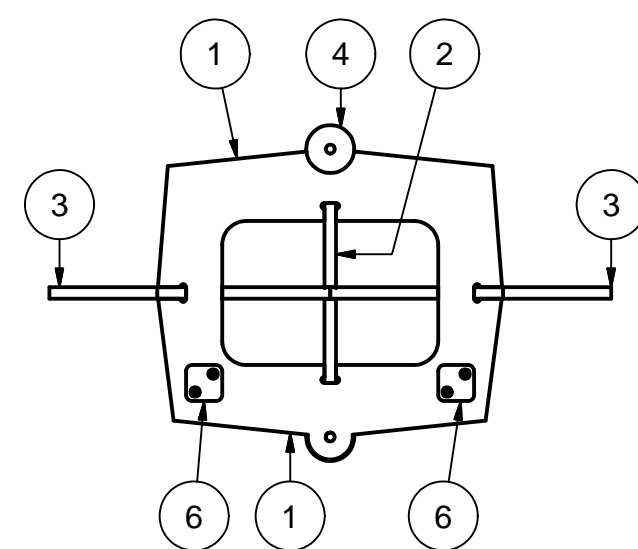

4 B9 FRAME - BOTTOM
1-1/2"=1'-0"
1 REQUIRED

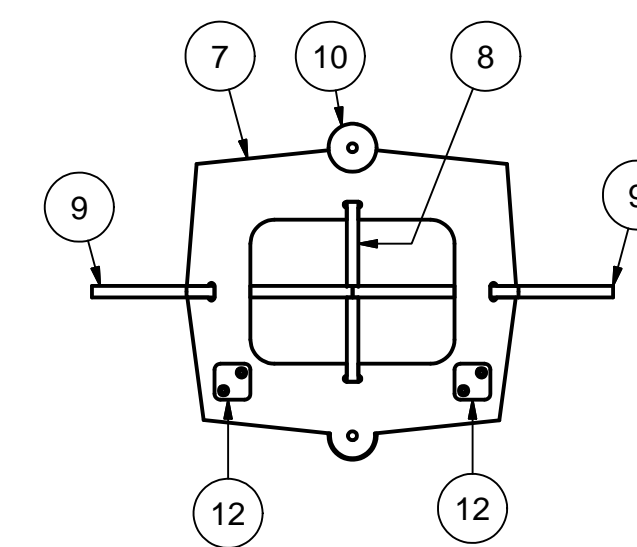

8 B10 FRAME - BOTTOM
1-1/2"=1'-0"
1 REQUIRED

SNAKE BODY FRAME LAYOUTS
SAN FRANCISCO OPERA
MAGIC FLUTE 2012

REFERENCED	
FROM	TO

JOB ID:

DRAWN BY: Ken Sly

APPROVED BY:

ORIGINAL DATE: 1/30/2012

DUE DATE:

SCALE: 1-1/2"=1'-0"

SB6

LATEST REVISION **A**

Parts List			
ITEM	QTY	PART NUMBER	DESCRIPTION
1	1	Snake B11 B	SHEET SP1 VIEW 11
2	1	Snake B11 S	SHEET SP3 VIEW 12
3	2	Snake B11 R	SHEET SP5 VIEW 12
4	2	Snake Tab Hole	SHEET SP7 VIEW 1
5	1	Snake Tab Slot	SHEET SP7 VIEW 2
6	2	Snake Slider	SHEET SP7 VIEW 1-4

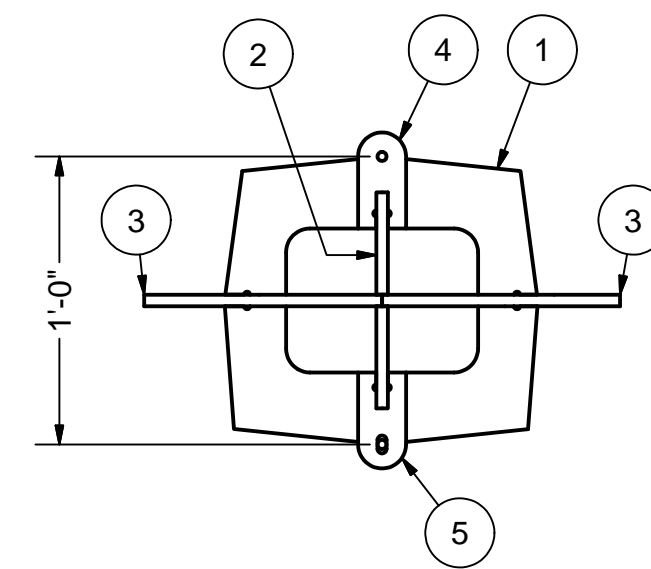

1 B11 FRAME - PLAN
1-1/2"=1'-0"
1 REQUIRED

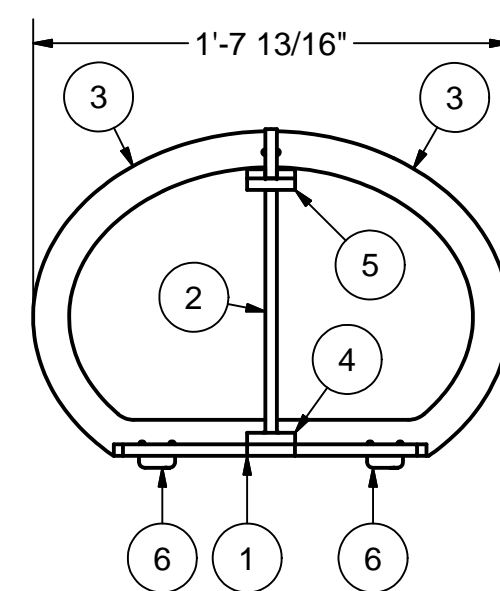

2 B11 FRAME - FACE
1-1/2"=1'-0"
1 REQUIRED

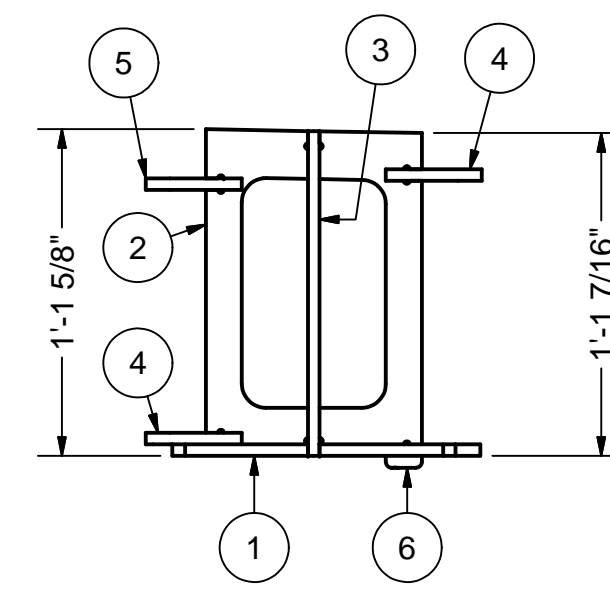

3 B11 FRAME - SIDE
1-1/2"=1'-0"
1 REQUIRED

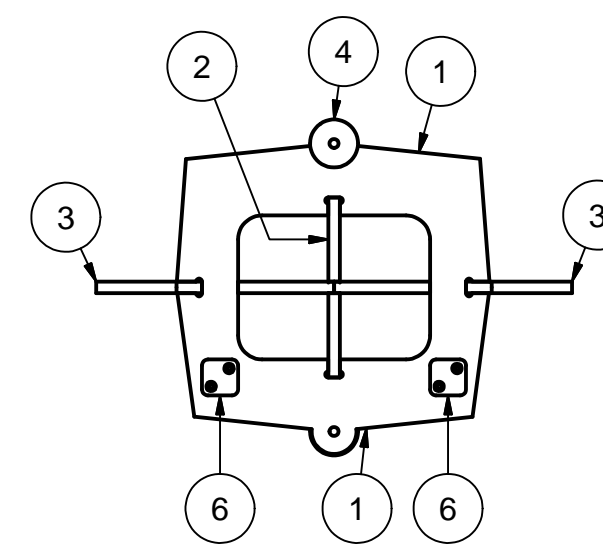

4 B11 FRAME - BOTTOM
1-1/2"=1'-0"
1 REQUIRED

Parts List			
ITEM	QTY	PART NUMBER	DESCRIPTION
7	1	Snake B12 B	SHEET SP1 VIEW 12
8	1	Snake B12 S	SHEET SP3 VIEW 13
9	2	Snake B12 R	SHEET SP5 VIEW 13
10	2	Snake Tab Hole	SHEET SP7 VIEW 1
11	1	Snake Tab Slot	SHEET SP7 VIEW 2
12	2	Snake Slider	SHEET SP7 VIEW 3-4

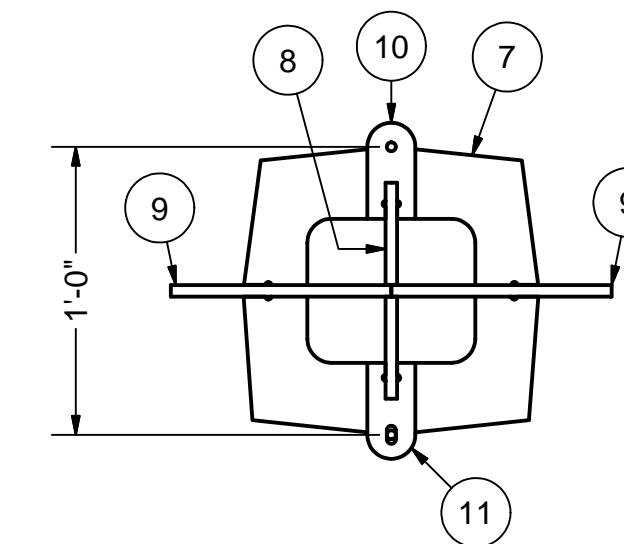

5 B12 FRAME - PLAN
1-1/2"=1'-0"
1 REQUIRED

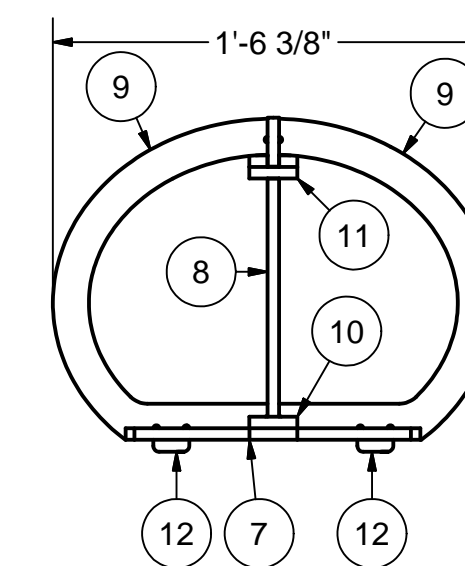

6 B12 FRAME - FACE
1-1/2"=1'-0"
1 REQUIRED

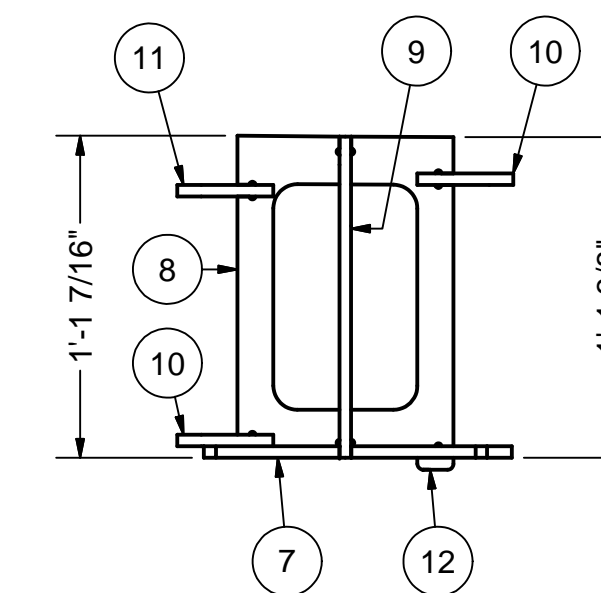

7 B12 FRAME - SIDE
1-1/2"=1'-0"
1 REQUIRED

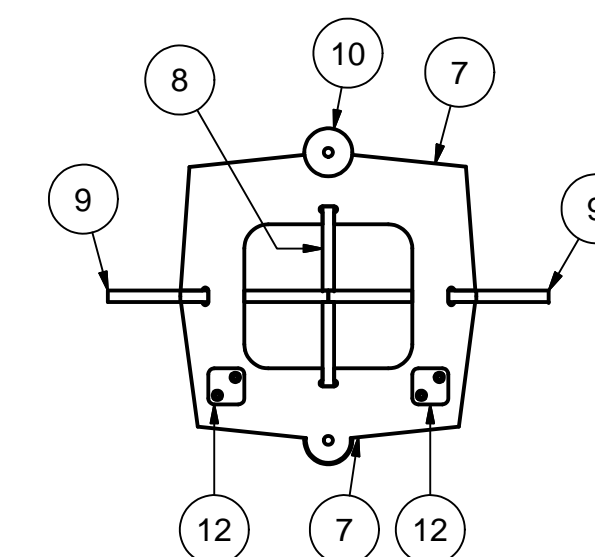

8 B12 FRAME - BOTTOM
1-1/2"=1'-0"
1 REQUIRED

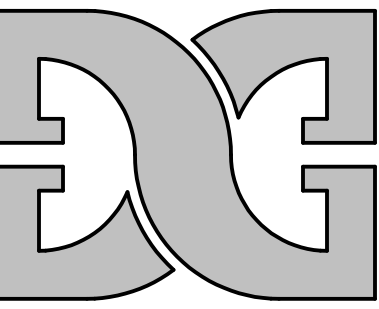

DIMENSIONAL GRAPHICS
PHONE & FAX (650) 342-5724
ken@diglow.com
www.diglow.com
MATERIAL CALLOUTS ARE TO CLARIFY THE DESIGN INTENT. ALL DESIGN CONCEPTS AND MATERIALS MUST BE VERIFIED BY A LICENSED ENGINEER.

SNAKE BODY FRAME LAYOUTS
SAN FRANCISCO OPERA
MAGIC FLUTE 2012

REFERENCED	
FROM	TO

JOB ID: _____

DRAWN BY: Ken Sly

APPROVED BY: _____

ORIGINAL DATE: 1/30/2012

DUE DATE: _____

SCALE: 1-1/2"=1'-0"

SB7

LATEST REVISION **A**

4 ASSEMBLIES REQUIRED. MULTILY QUANTITY BY 4x.

Parts List			
ITEM	QTY	PART NUMBER	DESCRIPTION
1	1	Snake B13 B	SHEET SP1 VIEW 13
2	1	Snake B13 S	SHEET SP3 VIEW 14
3	2	Snake B13 R	SHEET SP5 VIEW 14
4	2	Snake Tab Hole	SHEET SP7 VIEW 1
5	1	Snake Tab Slot	SHEET SP7 VIEW 2
6	2	Snake Slider	SHEET SP7 VIEW 3-4

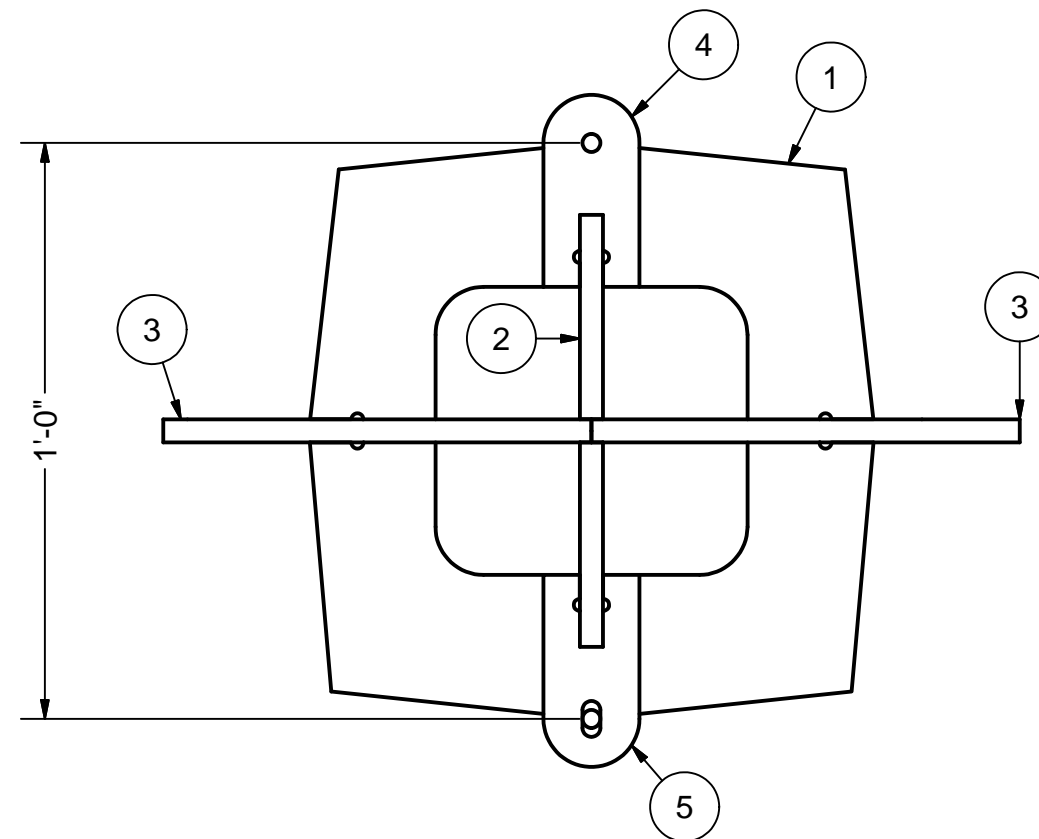

1 B13 FRAME - PLAN
3"=1'-0"
4 ASSEMBLIES REQUIRED

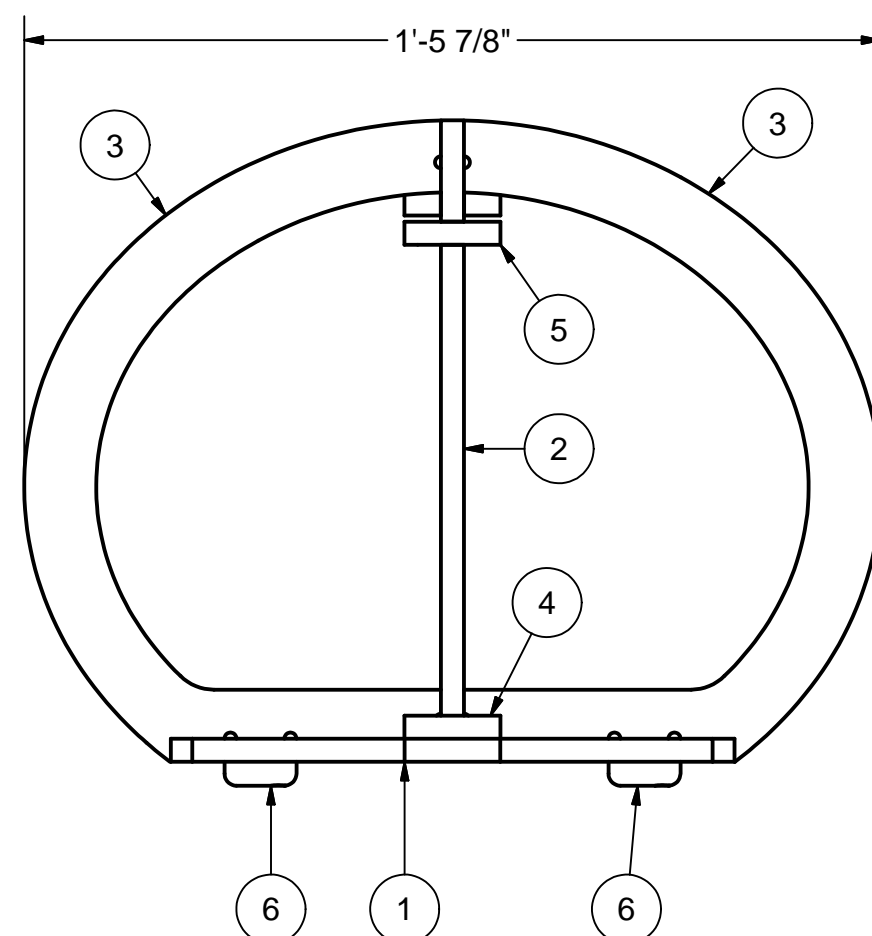

2 B13 FRAME - FACE
3"=1'-0"
4 ASSEMBLIES REQUIRED

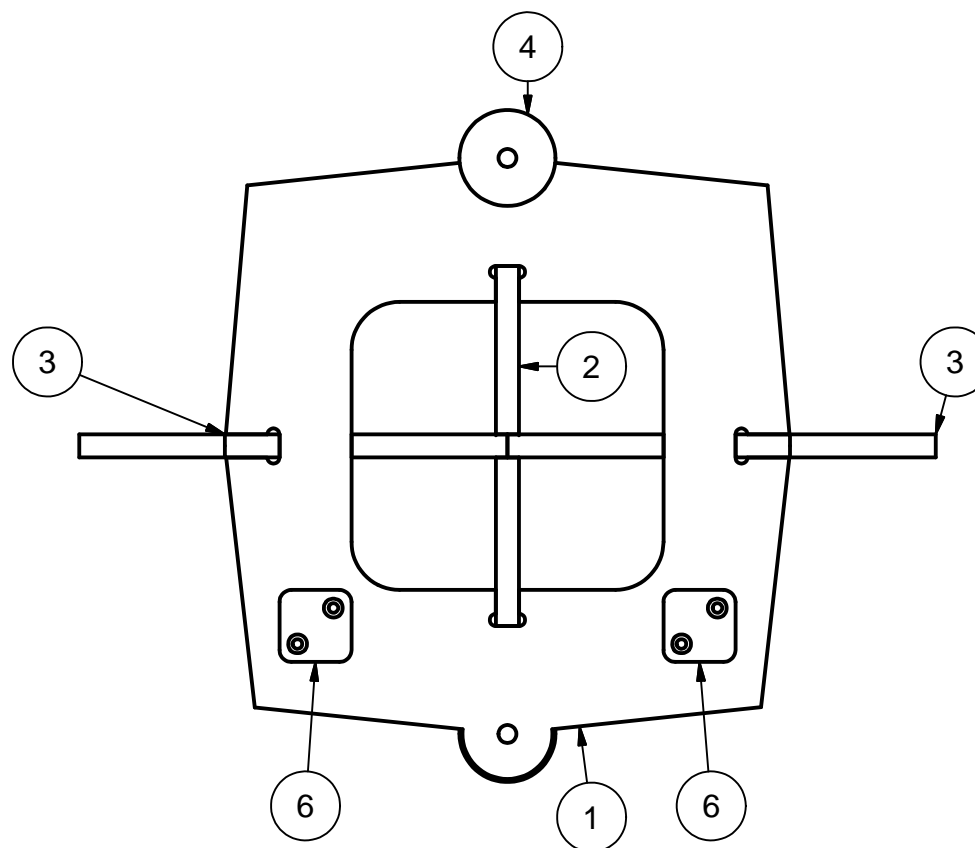

4 B13 FRAME - BOTTOM
3"=1'-0"
4 ASSEMBLIES REQUIRED

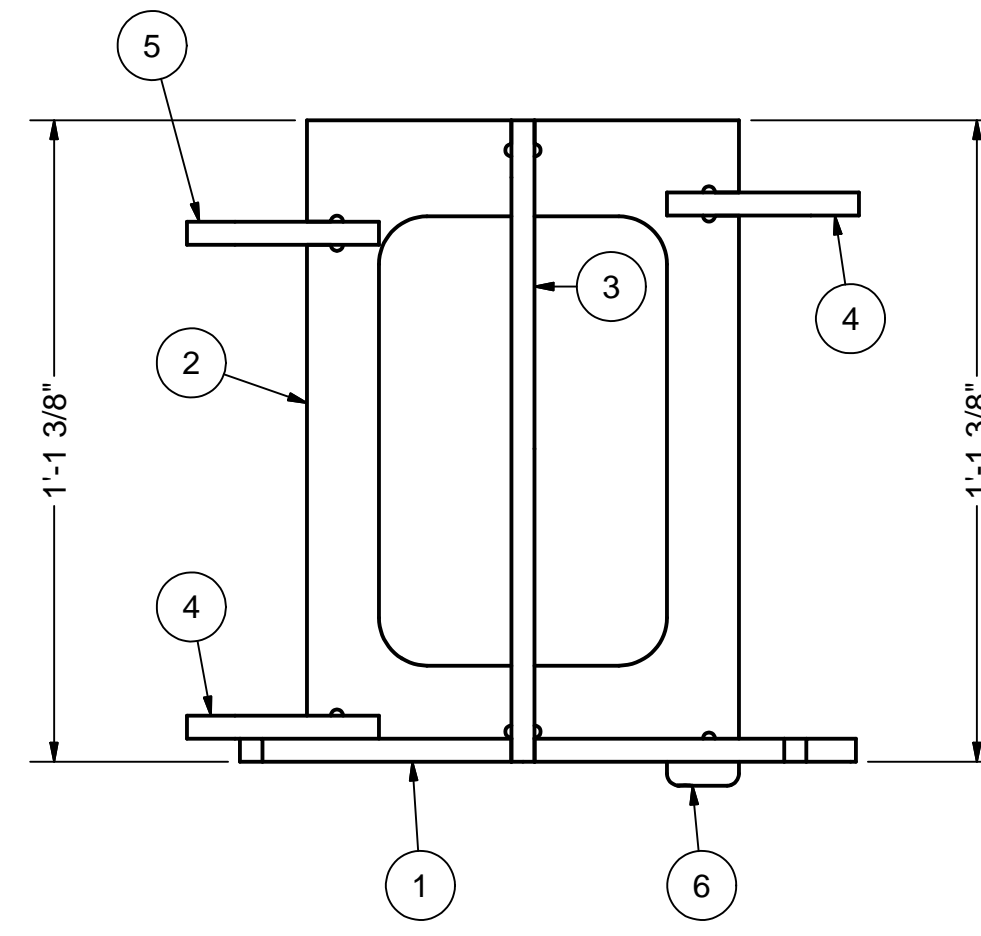

3 B13 FRAME - SIDE
3"=1'-0"
4 ASSEMBLIES REQUIRED

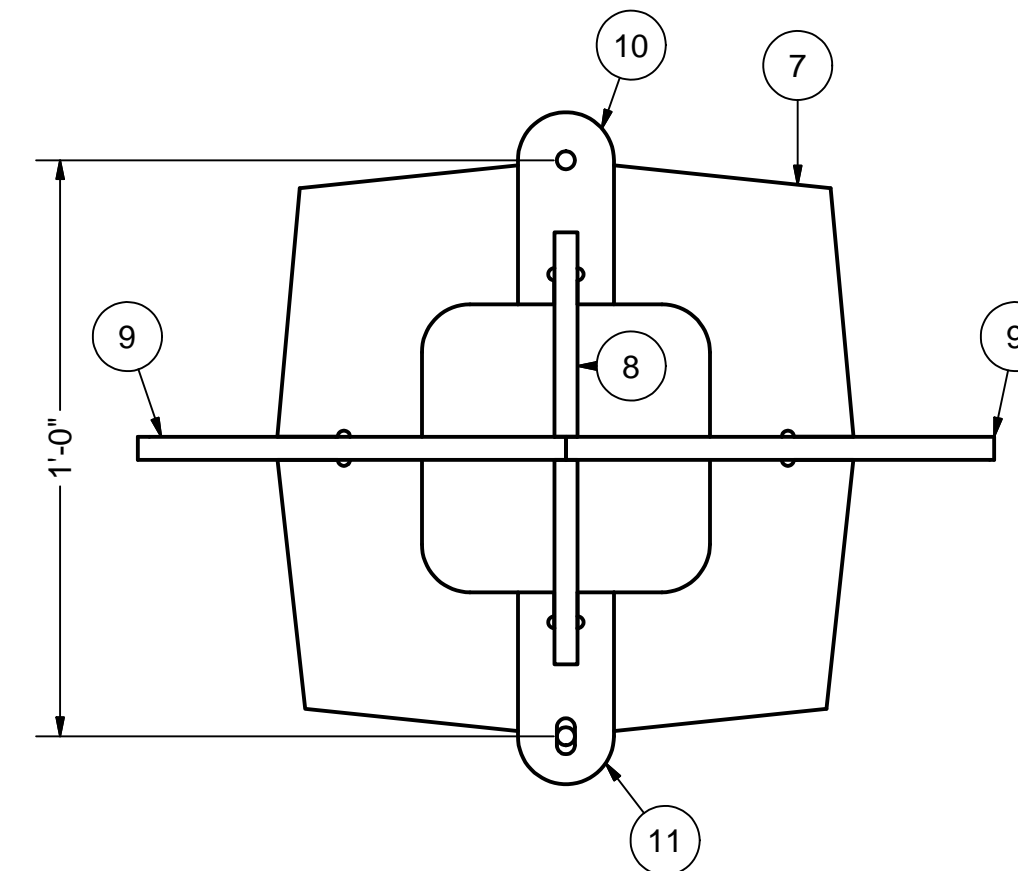

5 B14 FRAME - PLAN
3"=1'-0"
1 REQUIRED

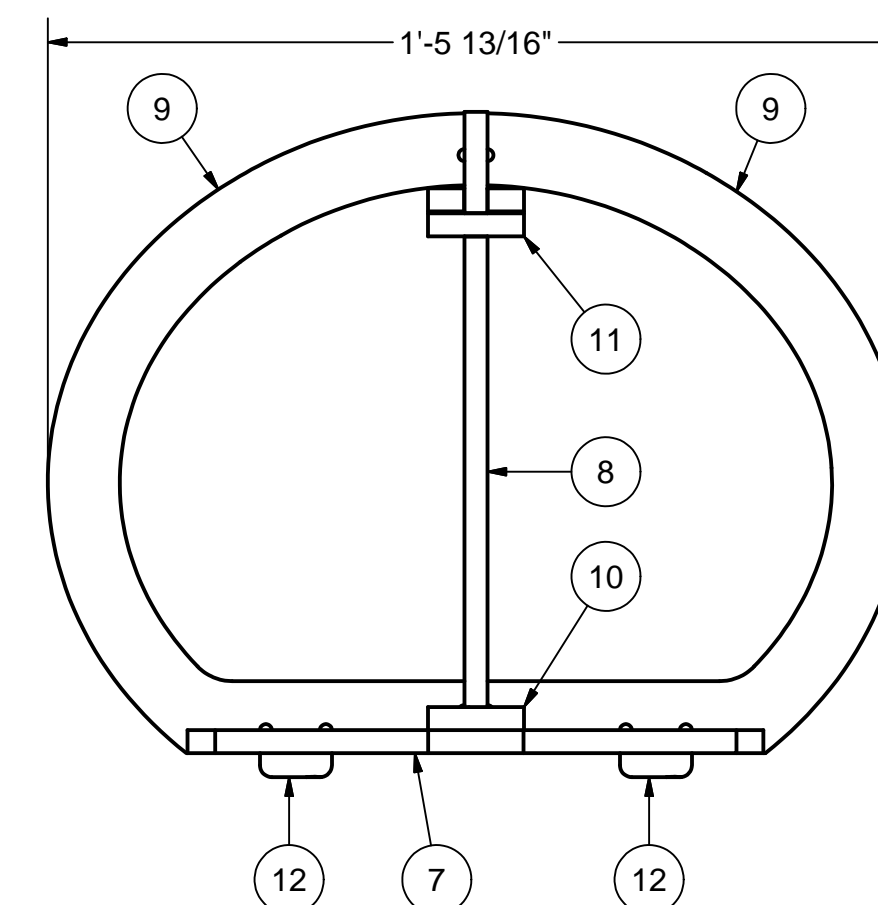

6 B14 FRAME - FACE
3"=1'-0"
1 REQUIRED

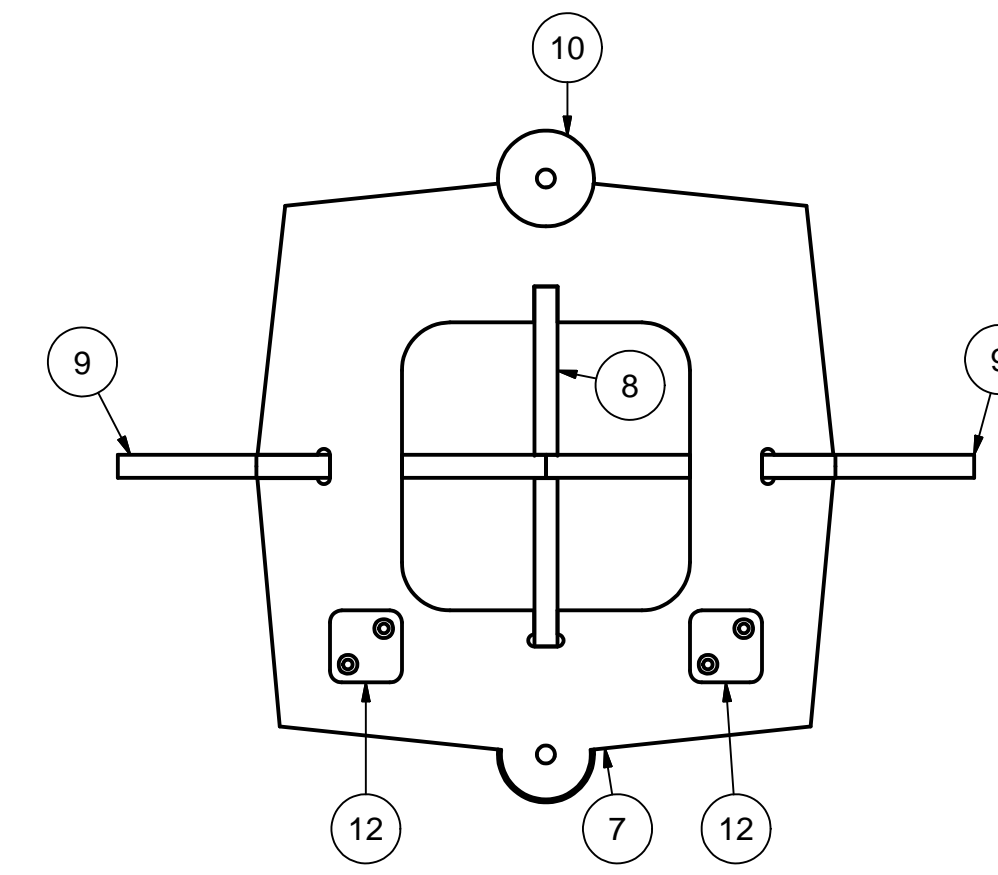

8 B14 FRAME - BOTTOM
3"=1'-0"
1 REQUIRED

Parts List			
ITEM	QTY	PART NUMBER	DESCRIPTION
7	1	Snake B14 B	SHEET SP1 VIEW 14
8	1	Snake B14 S	SHEET SP3 VIEW 15
9	2	Snake B14 R	SHEET SP5 VIEW 15
10	2	Snake Tab Hole	SHEET SP7 VIEW 1
11	1	Snake Tab Slot	SHEET SP7 VIEW 2
12	2	Snake Slider	SHEET SP7 VIEW 3-4

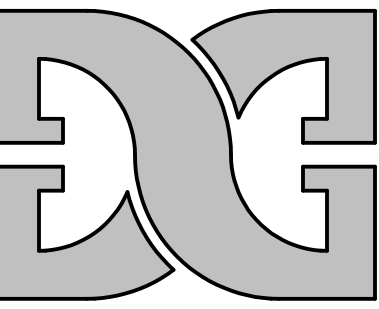

DIMENSIONAL GRAPHICS
PHONE & FAX (650) 342-5724
ken@dgflow.com
www.dgflow.com
MATERIAL CALLOUTS ARE TO CLARIFY THE DESIGN INTENT. ALL DESIGN CONCEPTS AND MATERIALS MUST BE VERIFIED BY A LICENSED ENGINEER.

SNAKE BODY FRAME LAYOUTS
SAN FRANCISCO OPERA
MAGIC FLUTE 2012

REFERENCED	
FROM	TO

JOB ID: _____
DRAWN BY: Ken Sly
APPROVED BY: _____
ORIGINAL DATE: 1/30/2012
DUE DATE: _____
SCALE: 3"=1'-0"

SB8
LATEST REVISION **A**

Parts List			
ITEM	QTY	PART NUMBER	DESCRIPTION
1	1	Snake B15 B	SHEET SP1 VIEW 15
2	1	Snake B15 S	SHEET SP4 VIEW 1
3	2	Snake B15 R	SHEET SP6 VIEW 1
4	2	Snake Tab Hole	SHEET SP7 VIEW 1
5	1	Snake Tab Slot	SHEET SP7 VIEW 2
6	2	Snake Slider	SHEET SP7 VIEW 3-4

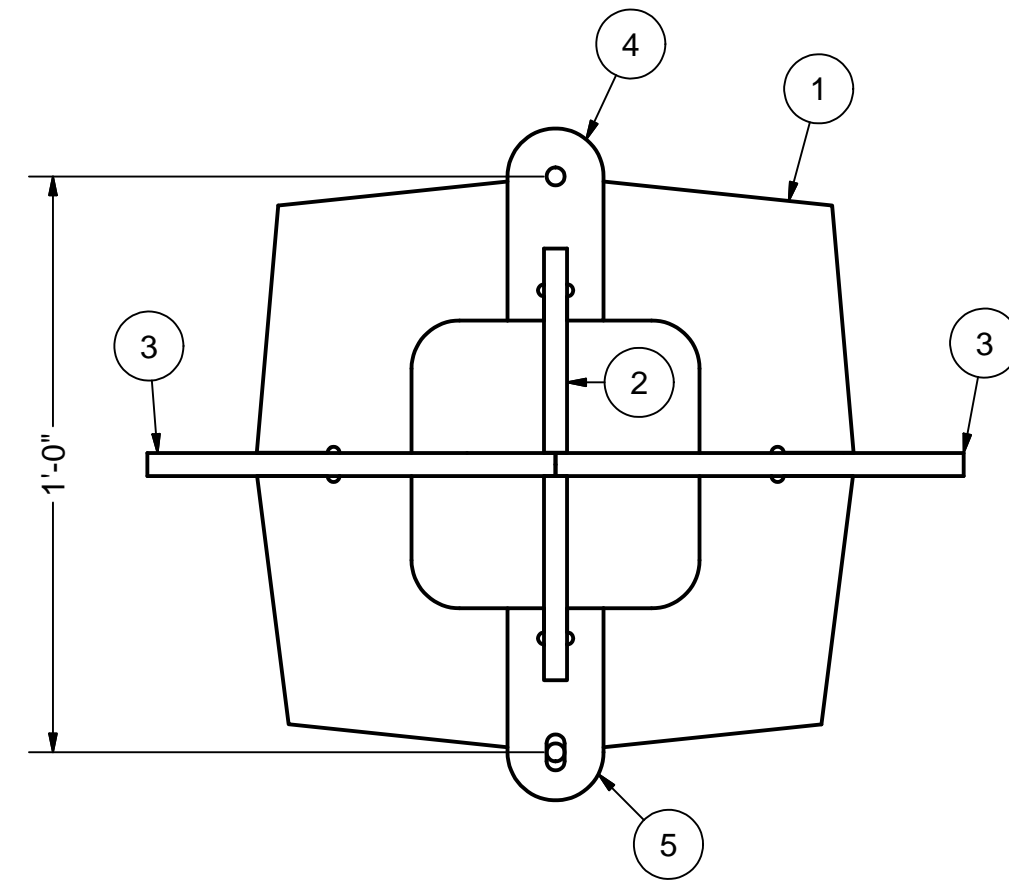

1 B15 FRAME - PLAN
3"=1'-0"
1 REQUIRED

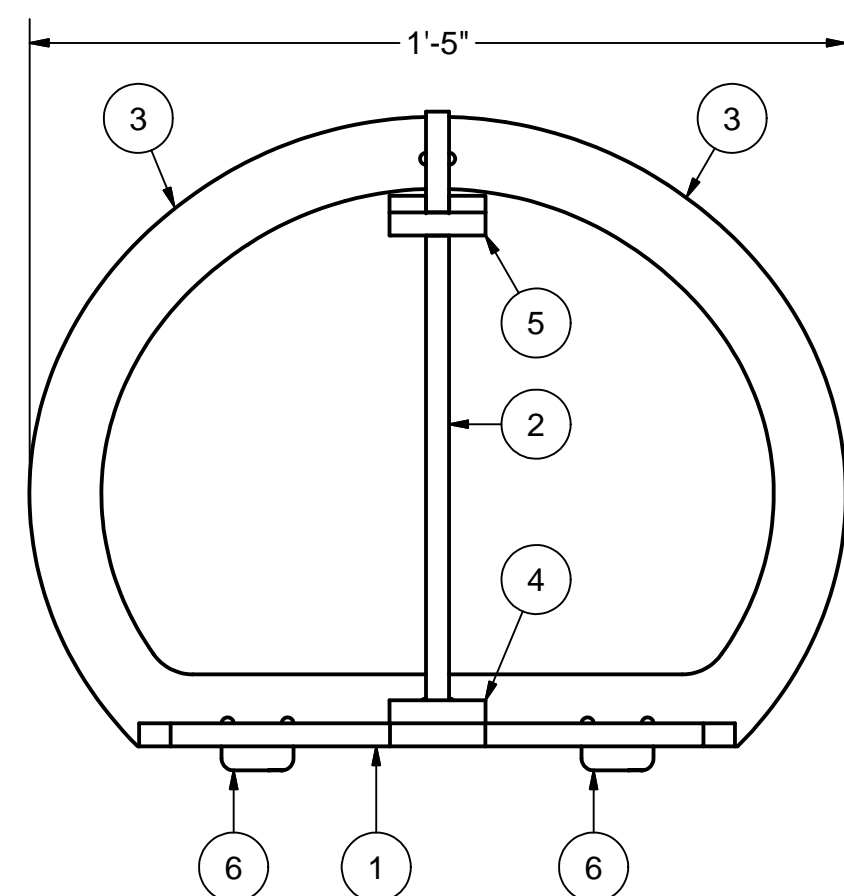

2 B15 FRAME - FACE
3"=1'-0"
1 REQUIRED

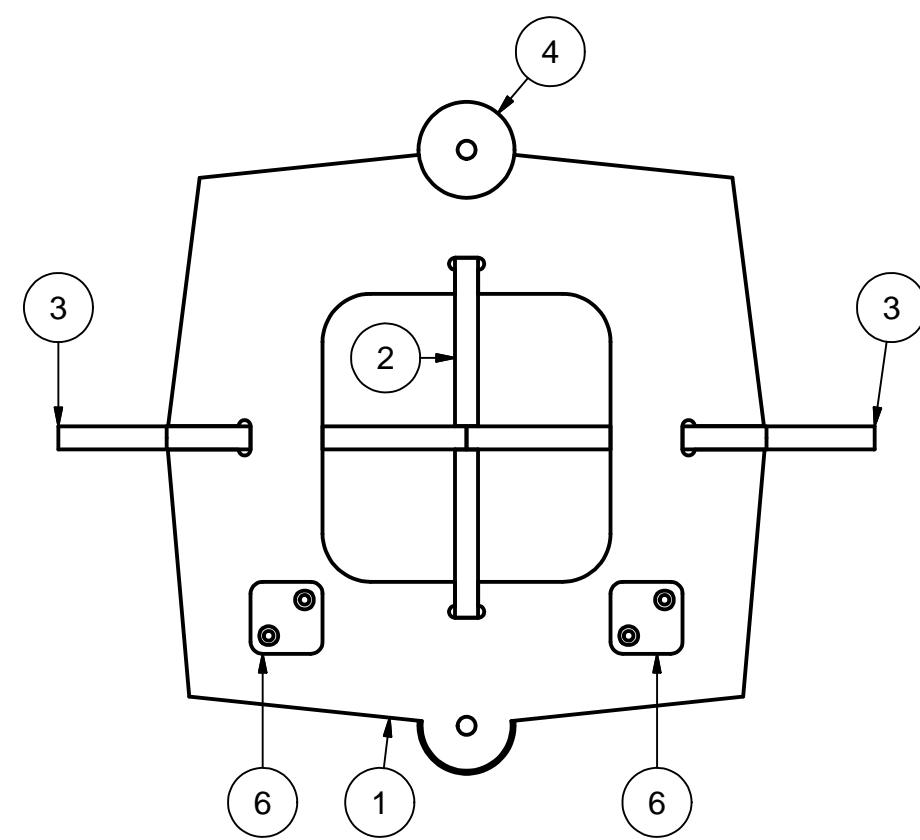

4 B15 FRAME - BOTTOM
3"=1'-0"
1 REQUIRED

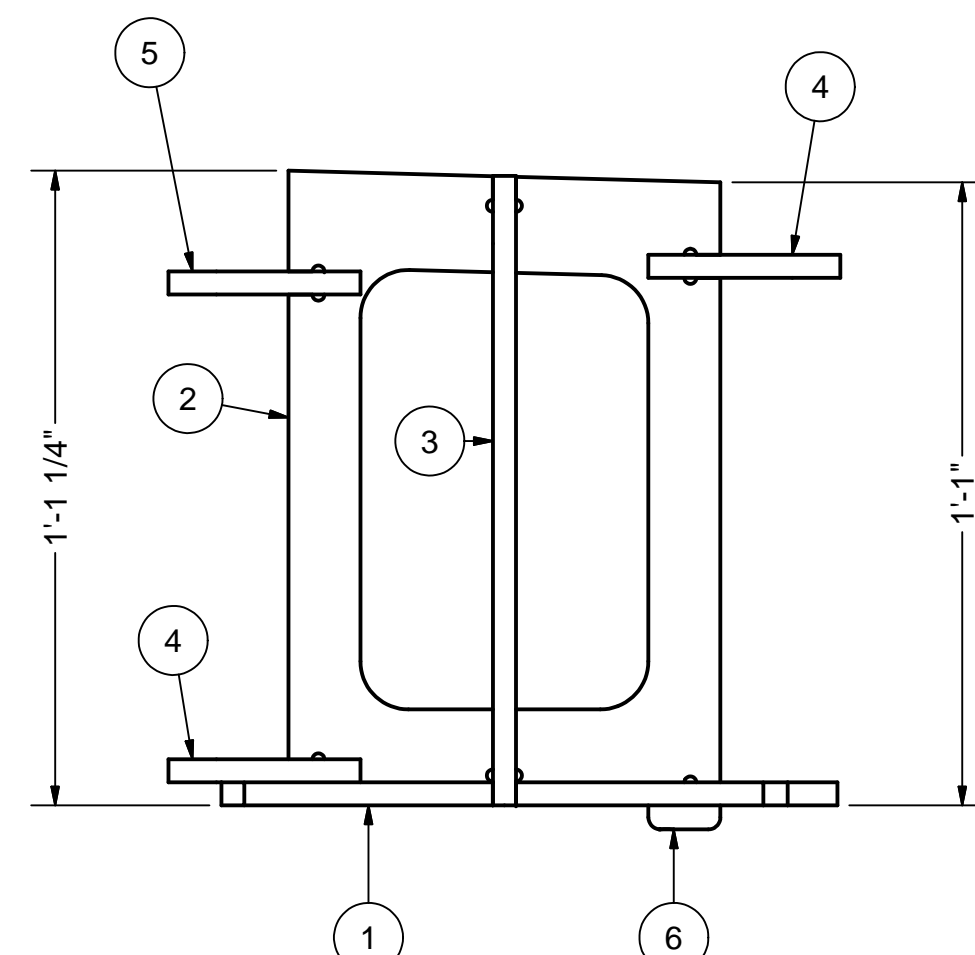

3 B15 FRAME - SIDE
3"=1'-0"
1 REQUIRED

Parts List			
ITEM	QTY	PART NUMBER	DESCRIPTION
7	1	Snake B16 B	SHEET SP2 VIEW 1
8	1	Snake B16 S	SHEET SP4 VIEW 2
9	2	Snake B16 R	SHEET SP6 VIEW 2
10	2	Snake Tab Hole	SHEET SP7 VIEW 1
11	1	Snake Tab Slot	SHEET SP7 VIEW 2
12	2	Snake Slider	SHEET SP7 VIEW 3-4

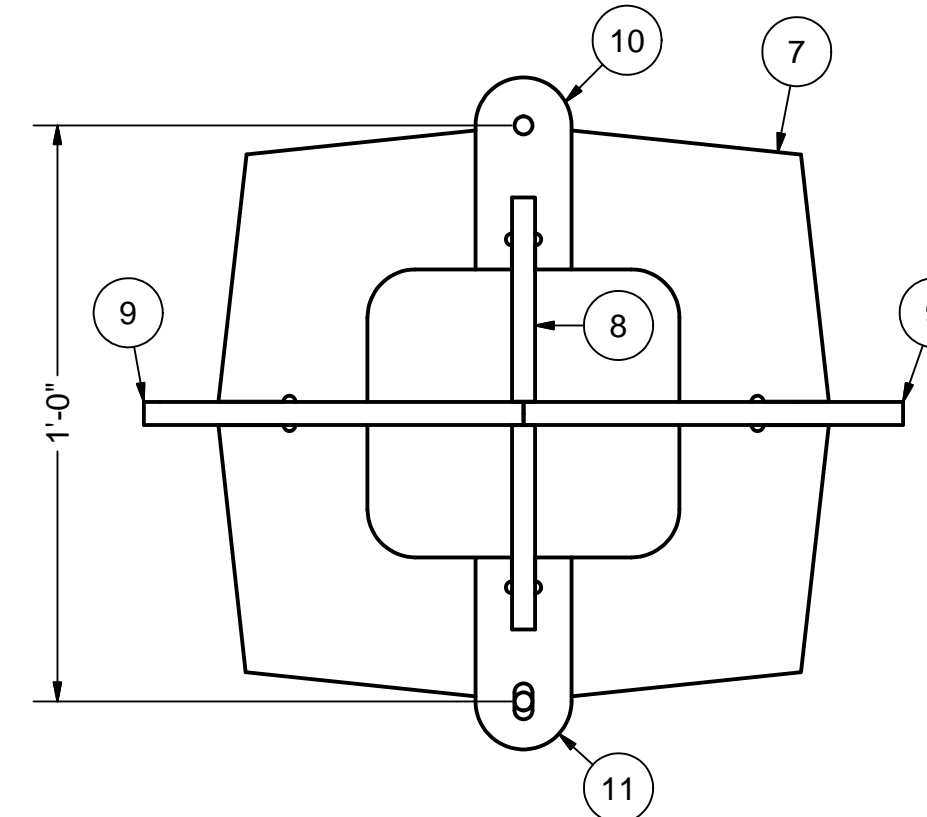

5 B16 FRAME - PLAN
3"=1'-0"
1 REQUIRED

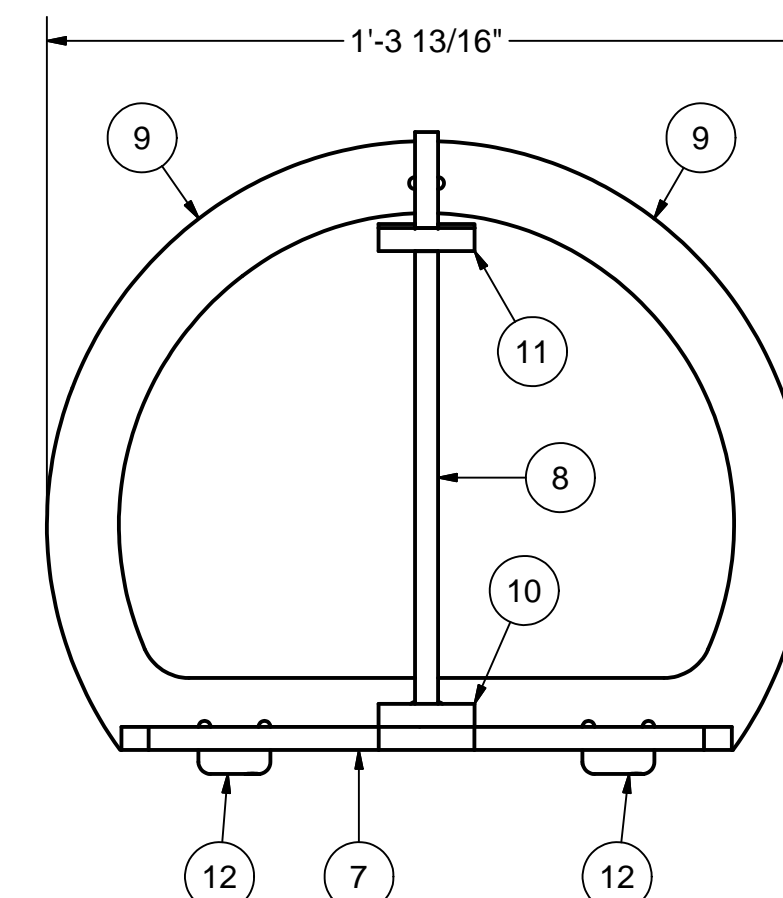

6 B16 FRAME - FACE
3"=1'-0"
1 REQUIRED

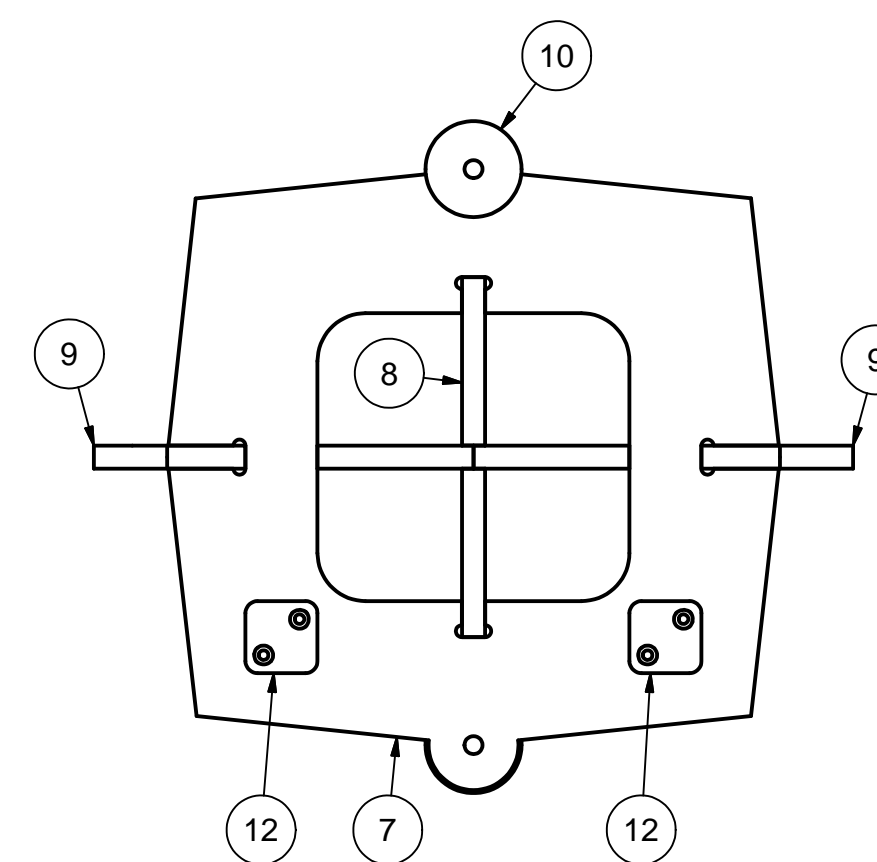

8 B16 FRAME - BOTTOM
3"=1'-0"
1 REQUIRED

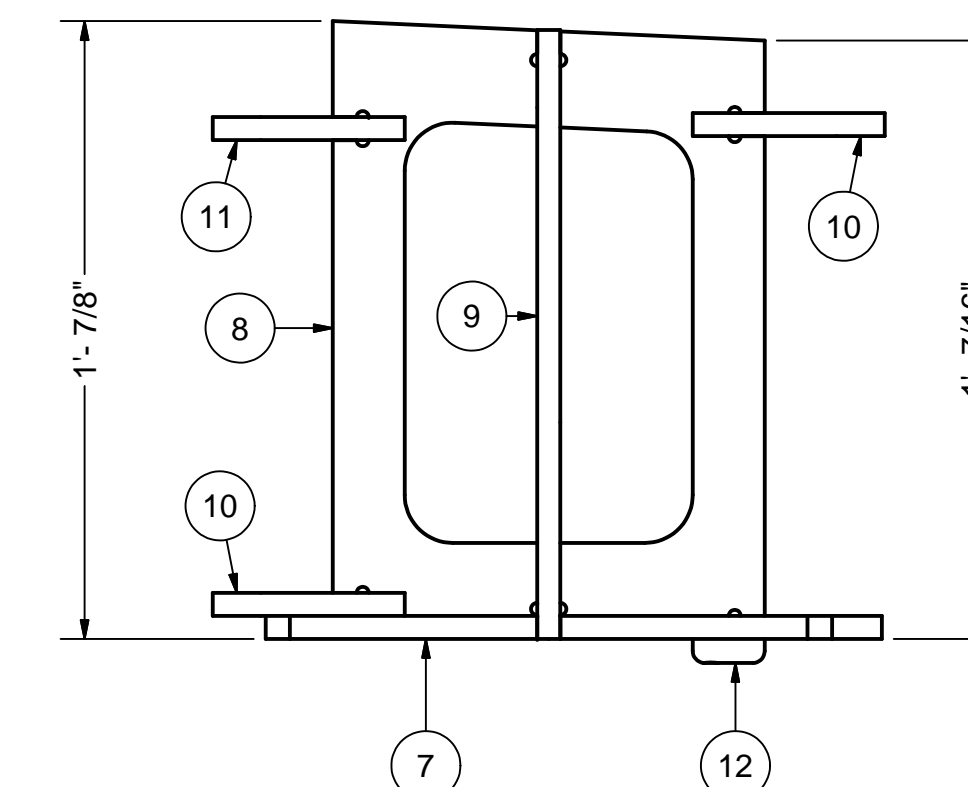

7 B16 FRAME - SIDE
3"=1'-0"
1 REQUIRED

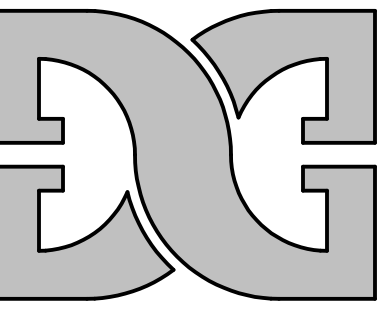

**DIMENSIONAL
GRAPHICS**
PHONE & FAX (650) 342-5724
ken@diglow.com
www.diglow.com
MATERIAL CALLOUTS ARE TO CLARIFY THE
DESIGN INTENT. ALL DESIGN CONCEPTS AND
MATERIALS MUST BE VERIFIED BY A
LICENSED ENGINEER.

SNAKE BODY FRAME LAYOUTS
SAN FRANCISCO OPERA
MAGIC FLUTE 2012

REFERENCED	
FROM	TO

JOB ID: _____
DRAWN BY: Ken Sly
APPROVED BY: _____
ORIGINAL DATE: 1/30/2012
DUE DATE: _____
SCALE: 3"=1'-0"

SB9
LATEST REVISION **A**

Parts List			
ITEM	QTY	PART NUMBER	DESCRIPTION
1	1	Snake B17 B	SHEET SP2 VIEW 2
2	1	Snake B17 S	SHEET SP4 VIEW 3
3	2	Snake B17 R	SHEET SP6 VIEW 3
4	2	Snake Tab Hole	SHEET SP7 VIEW 1
5	1	Snake Tab Slot	SHEET SP7 VIEW 2
6	2	Snake Slider	SHEET SP7 VIEW 1-3

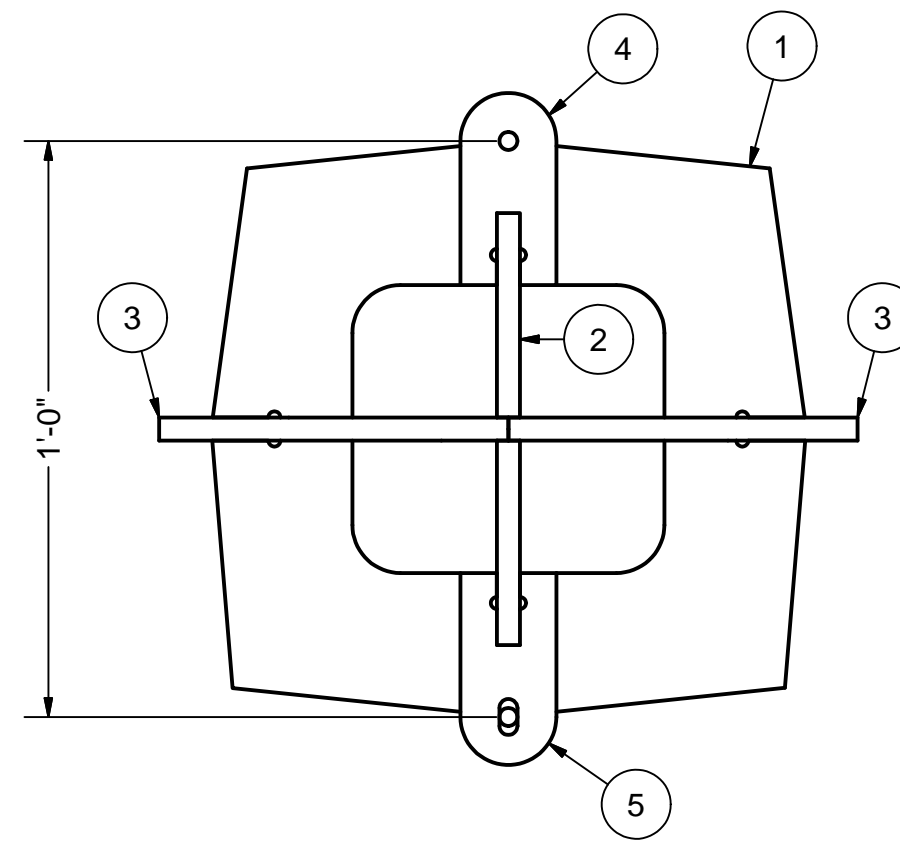

1 B17 FRAME - PLAN
3"=1'-0"
1 REQUIRED

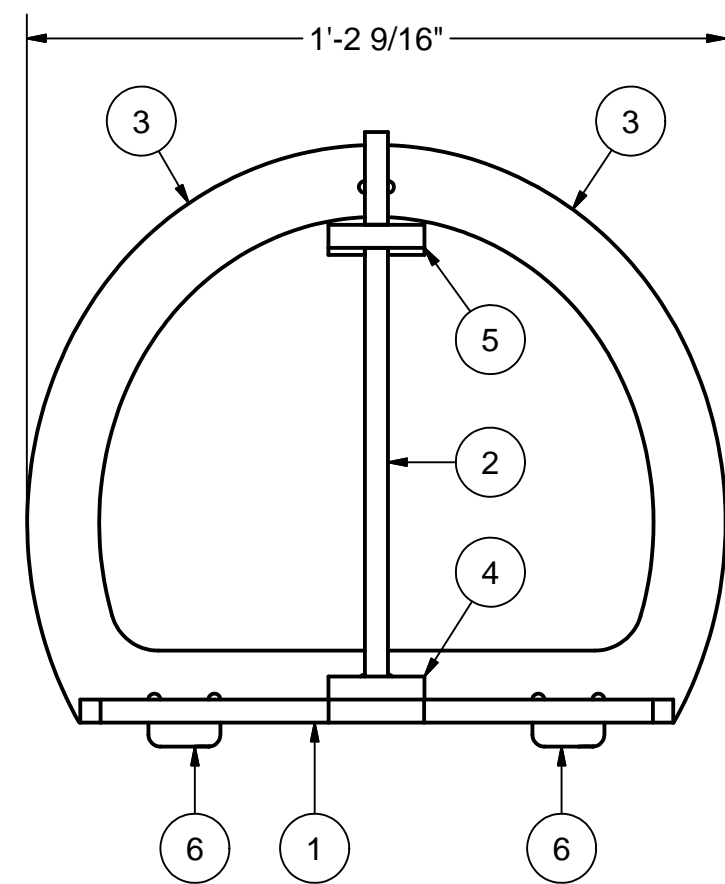

2 B17 FRAME - FACE
3"=1'-0"
1 REQUIRED

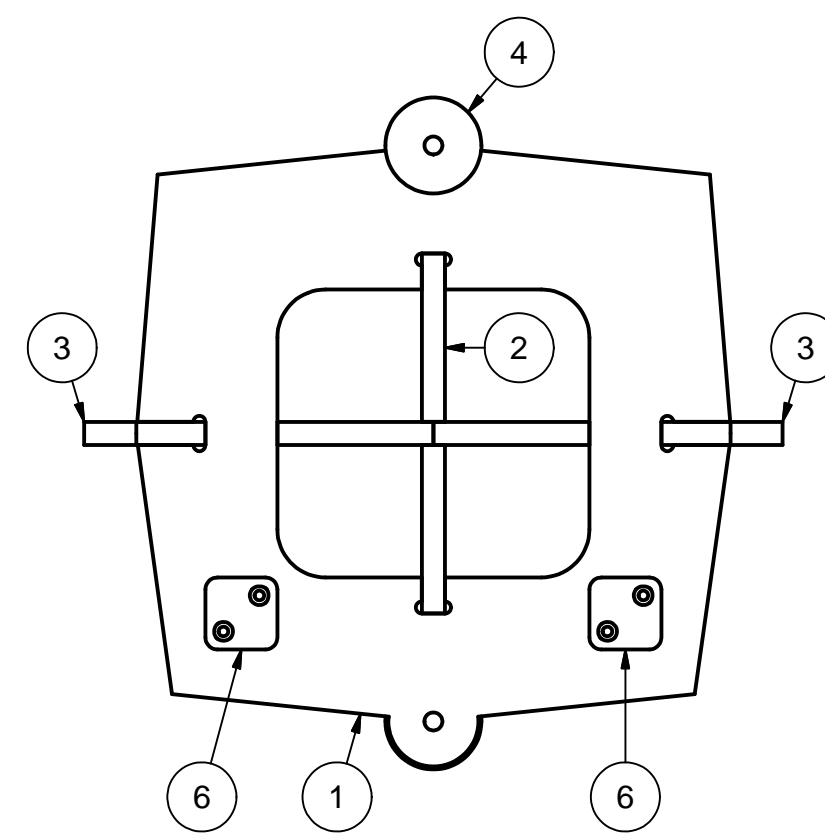

4 B17 FRAME - BOTTOM
3"=1'-0"
1 REQUIRED

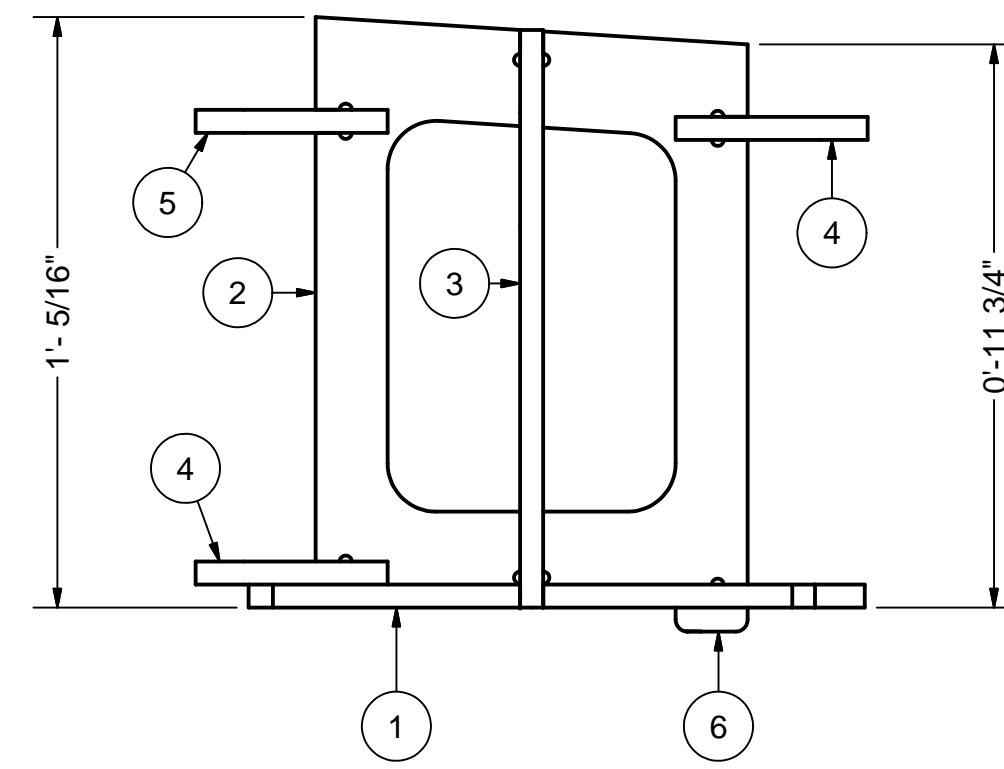

3 B17 FRAME - SIDE
3"=1'-0"
1 REQUIRED

Parts List			
ITEM	QTY	PART NUMBER	DESCRIPTION
7	1	Snake B18 B	SHEET SP2 VIEW 3
8	1	Snake B18 S	SHEET SP4 VIEW 4
9	2	Snake B18 R	SHEET SP6 VIEW 4
10	2	Snake Tab Hole	SHEET SP7 VIEW 1
11	1	Snake Tab Slot	SHEET SP7 VIEW 2
12	2	Snake Slider	SHEET SP7 VIEW 1-3

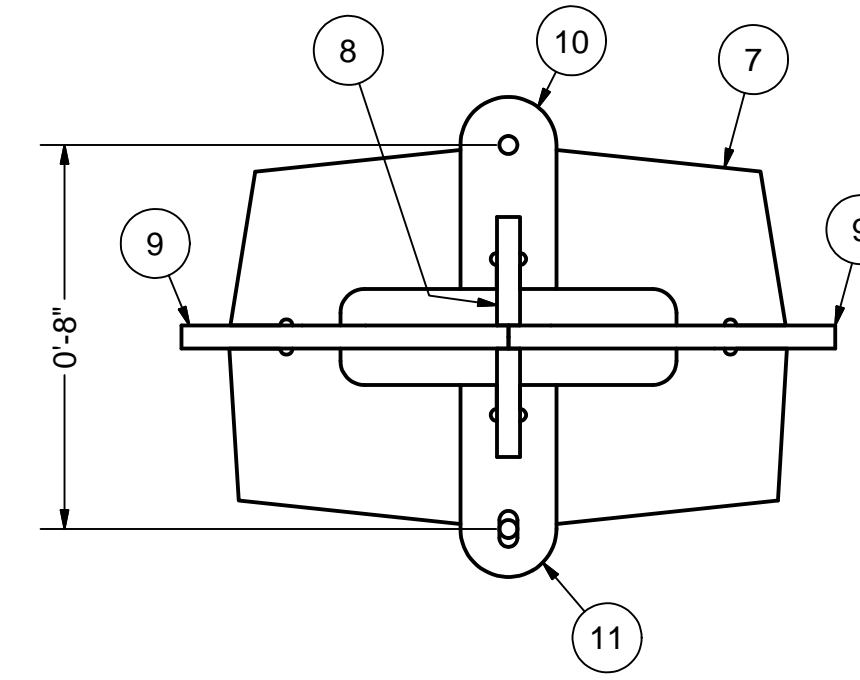

5 B18 FRAME - PLAN
3"=1'-0"
1 REQUIRED

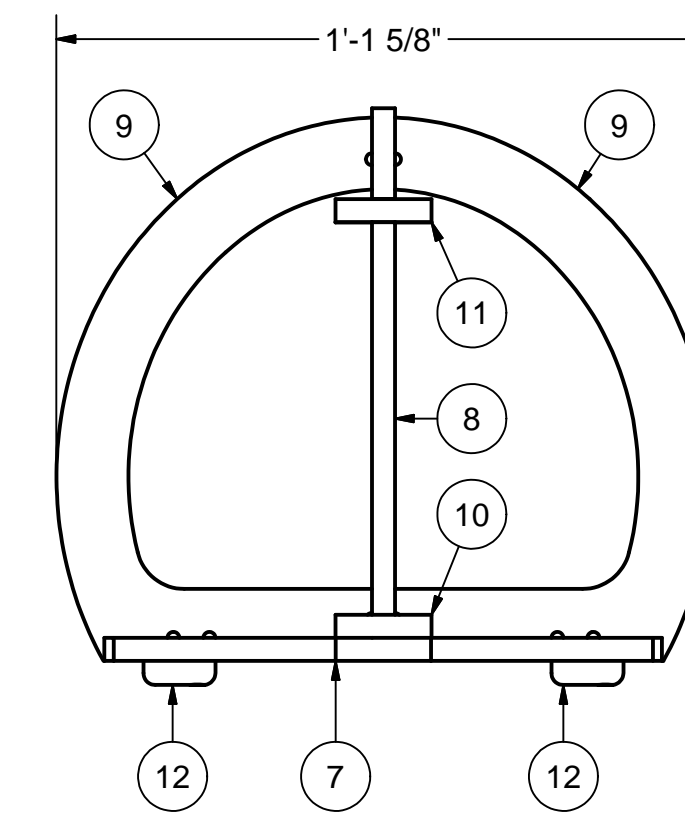

6 B18 FRAME - FACE
3"=1'-0"
1 REQUIRED

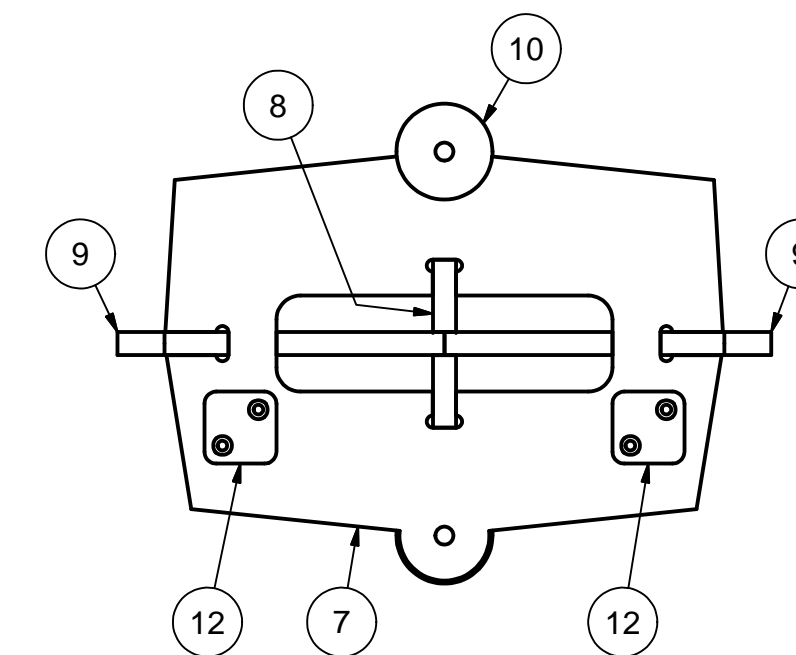

8 B18 FRAME - BOTTOM
3"=1'-0"
1 REQUIRED

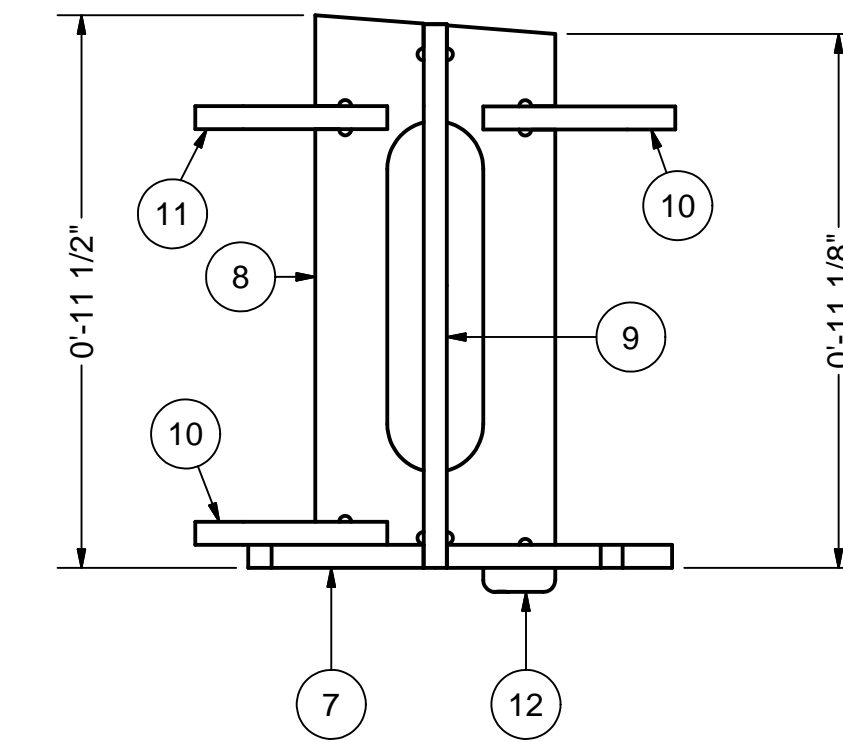

7 B18 FRAME - SIDE
3"=1'-0"
1 REQUIRED

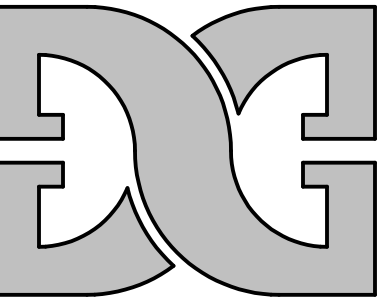

DIMENSIONAL GRAPHICS
PHONE & FAX (650) 342-5724
ken@dgflow.com
www.dgflow.com
MATERIAL CALLOUTS ARE TO CLARIFY THE DESIGN INTENT. ALL DESIGN CONCEPTS AND MATERIALS MUST BE VERIFIED BY A LICENSED ENGINEER.

SNAKE BODY PART LAYOUTS
SAN FRANCISCO OPERA
MAGIC FLUTE 2012

REFERENCED	
FROM	TO

JOB ID: _____
DRAWN BY: Ken Sly
APPROVED BY: _____
ORIGINAL DATE: 1/30/2012
DUE DATE: _____
SCALE: 3"=1'-0"

SB10
LATEST REVISION **A**

Parts List			
ITEM	QTY	PART NUMBER	DESCRIPTION
1	1	Snake B19 B	SHEET SP2 VIEW 4
2	1	Snake B19 S	SHEET SP4 VIEW 5
3	2	Snake B19 R	SHEET SP6 VIEW 5
4	2	Snake Tab Hole	SHEET SP7 VIEW 1
5	1	Snake Tab Slot	SHEET SP7 VIEW 2
6	2	Snake Slider	SHEET SP7 VIEW 3-4

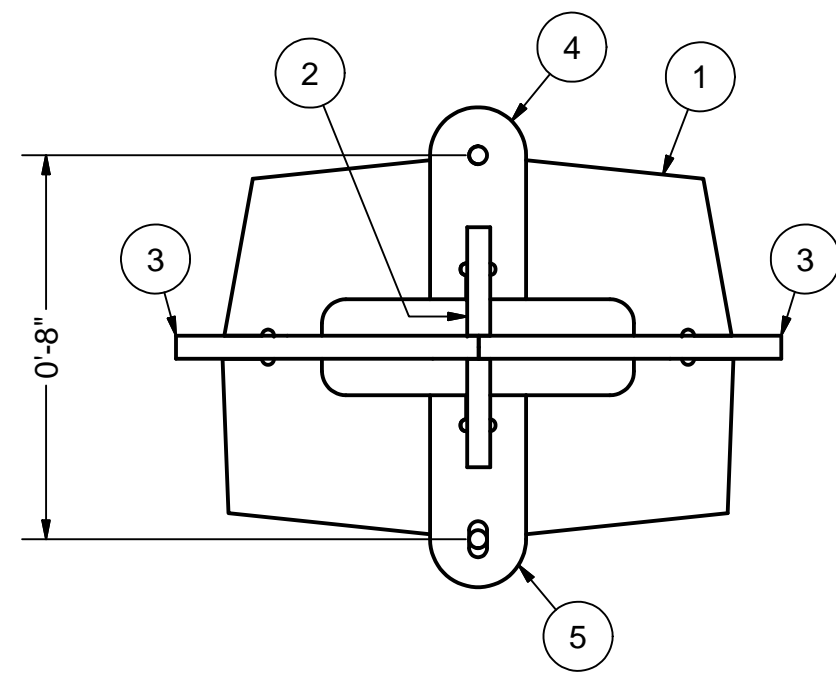

1 B19 FRAME - PLAN
3"=1'-0"
1 REQUIRED

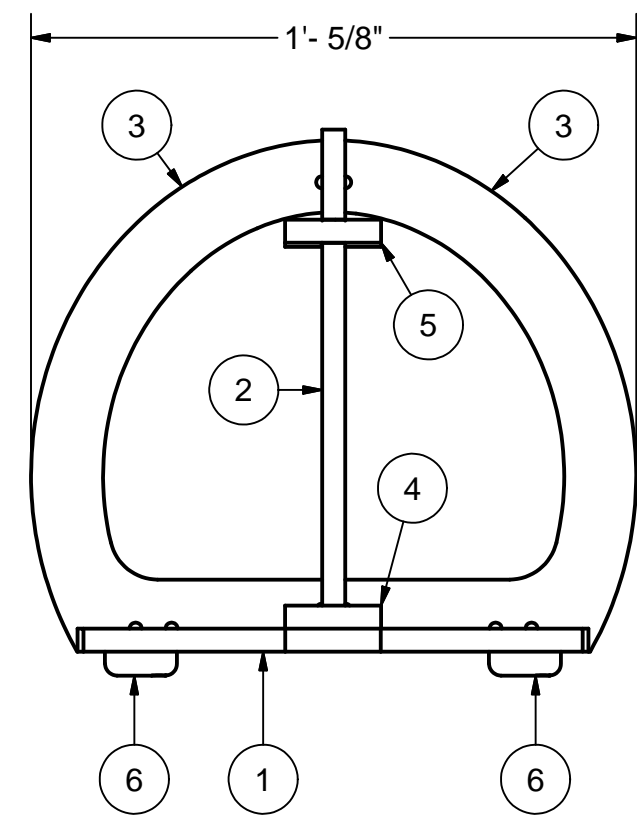

2 B19 FRAME - FACE
3"=1'-0"
1 REQUIRED

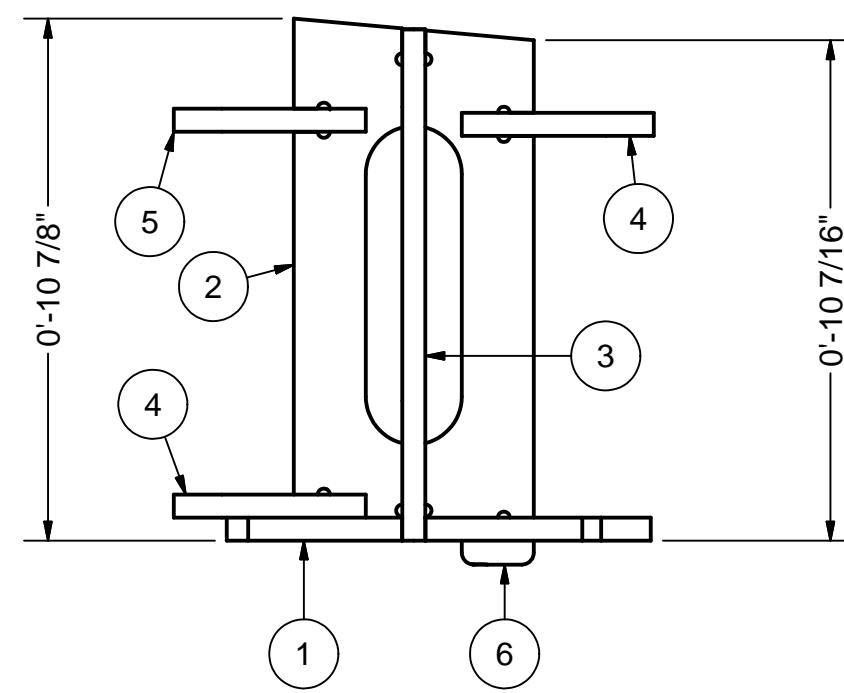

3 B19 FRAME - SIDE
3"=1'-0"
1 REQUIRED

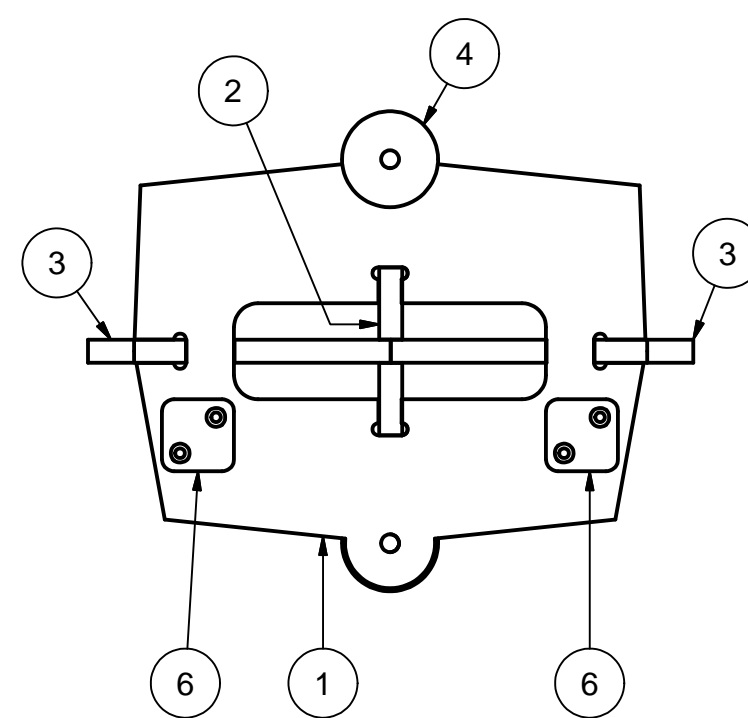

4 B19 FRAME - BOTTOM
3"=1'-0"
1 REQUIRED

Parts List			
ITEM	QTY	PART NUMBER	DESCRIPTION
7	1	Snake B20 B	SHEET SP2 VIEW 5
8	1	Snake B20 S	SHEET SP4 VIEW 6
9	2	Snake B20 R	SHEET SP6 VIEW 6
10	2	Snake Tab Hole	SHEET SP7 VIEW 1
11	1	Snake Tab Slot	SHEET SP7 VIEW 2
12	2	Snake Slider	SHEET SP7 VIEW 3-4

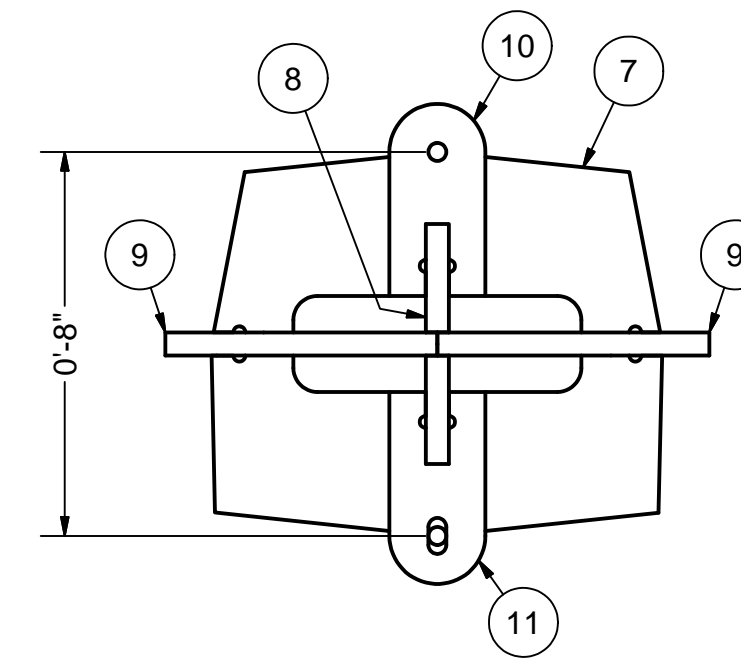

5 B20 FRAME - PLAN
3"=1'-0"
1 REQUIRED

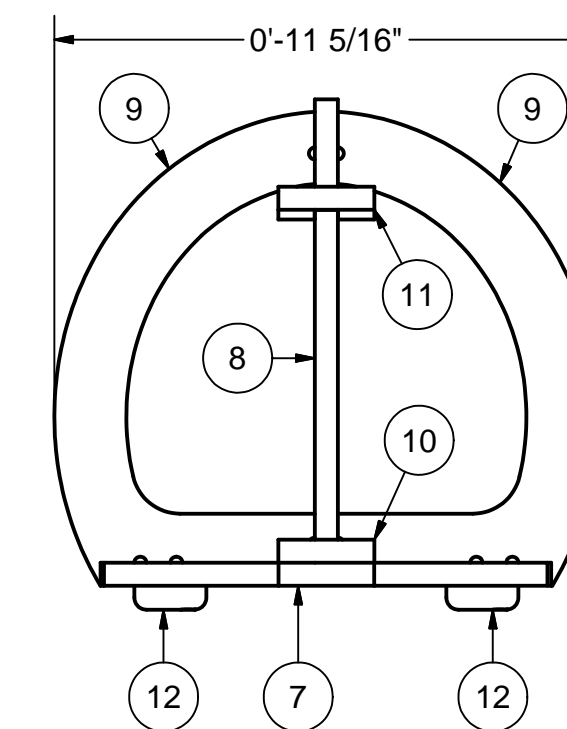

6 B20 FRAME - FACE
3"=1'-0"
1 REQUIRED

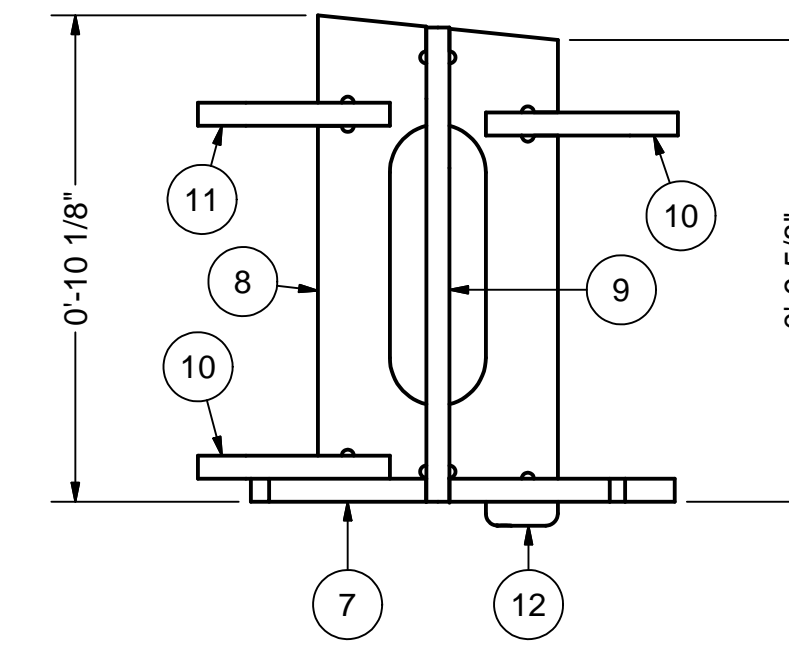

7 B20 FRAME - SIDE
3"=1'-0"
1 REQUIRED

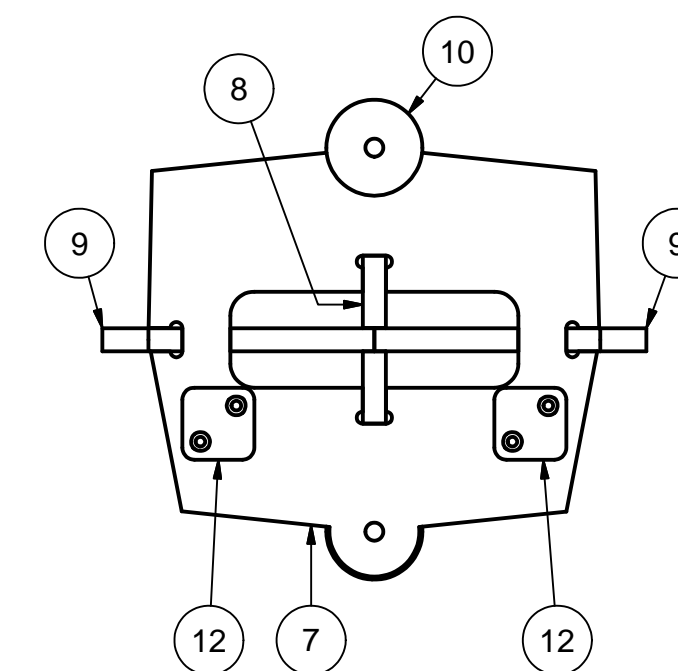

8 B20 FRAME - BOTTOM
3"=1'-0"
1 REQUIRED

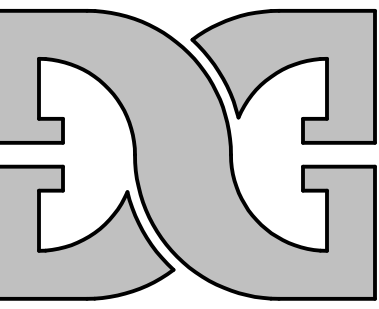

DIMENSIONAL GRAPHICS
PHONE & FAX (650) 342-5724
ken@dgflow.com
www.dgflow.com
MATERIAL CALLOUTS ARE TO CLARIFY THE DESIGN INTENT. ALL DESIGN CONCEPTS AND MATERIALS MUST BE VERIFIED BY A LICENSED ENGINEER.

SNAKE BODY PART LAYOUTS
SAN FRANCISCO OPERA
MAGIC FLUTE 2012

REFERENCED	
FROM	TO

JOB ID: _____
DRAWN BY: Ken Sly
APPROVED BY: _____
ORIGINAL DATE: 1/30/2012
DUE DATE: _____
SCALE: 3"=1'-0"
SB11
LATEST REVISION **A**

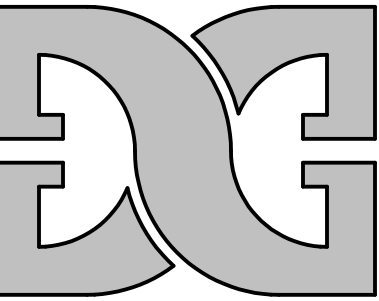

DIMENSIONAL GRAPHICS
 PHONE & FAX (650) 342-5724
 kenny@dgflow.com
 www.dgflow.com
 MATERIAL CALLOUTS ARE TO CLARIFY THE DESIGN INTENT. ALL DESIGN CONCEPTS AND MATERIALS MUST BE VERIFIED BY A LICENSED ENGINEER.

SNAKE BODY PART LAYOUTS
SAN FRANCISCO OPERA
MAGIC FLUTE 2012

Parts List			
ITEM	QTY	PART NUMBER	DESCRIPTION
1	1	Snake B21 B	SHEET SP2 VIEW 6
2	1	Snake B21 S	SHEET SP4 VIEW 7
3	2	Snake B21 R	SHEET SP6 VIEW 7
4	2	Snake Tab Hole	SHEET SP7 VIEW 1
5	1	Snake Tab Slot	SHEET SP7 VIEW 2
6	2	Snake Slider	SHEET SP7 VIEW 3-4

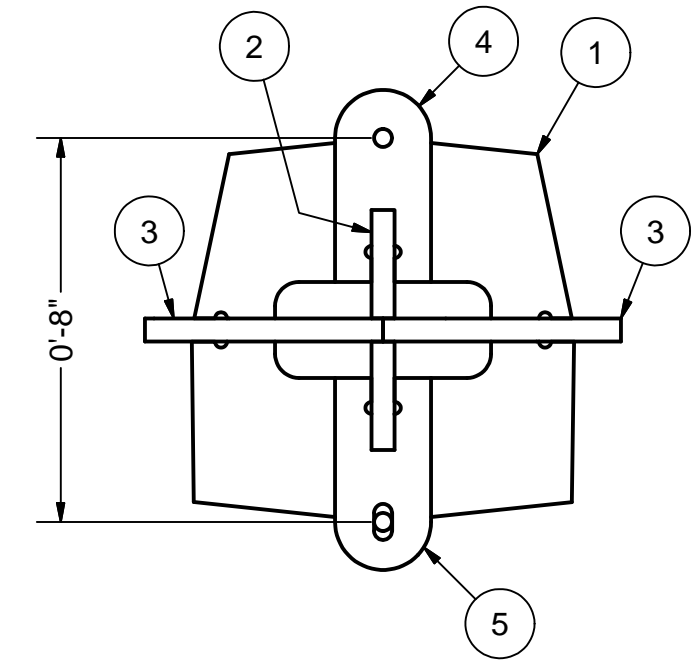

1 B21 FRAME - PLAN
 3"=1'-0"
 1 REQUIRED

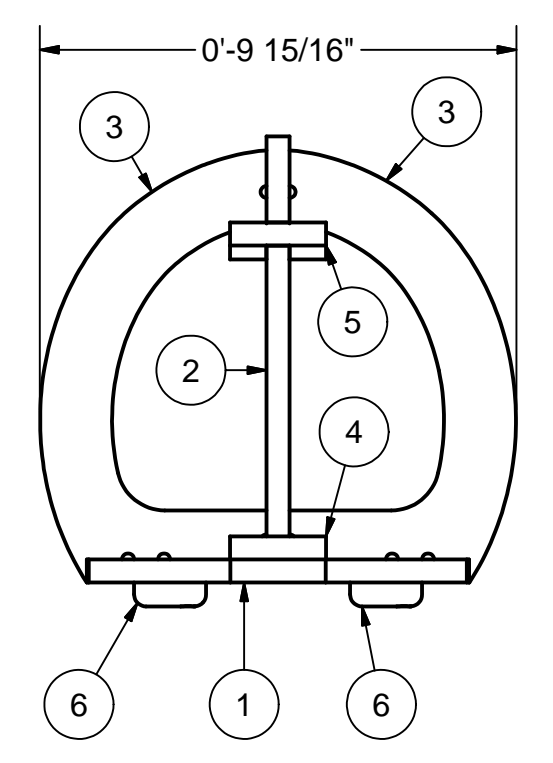

2 B21 FRAME - FACE
 3"=1'-0"
 1 REQUIRED

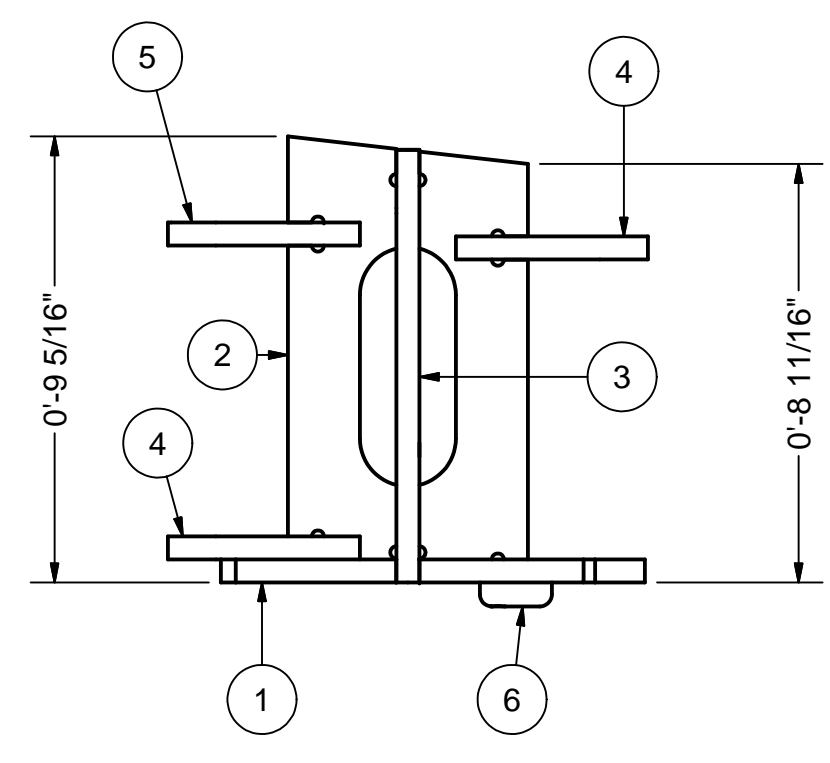

3 B21 FRAME - SIDE
 3"=1'-0"
 1 REQUIRED

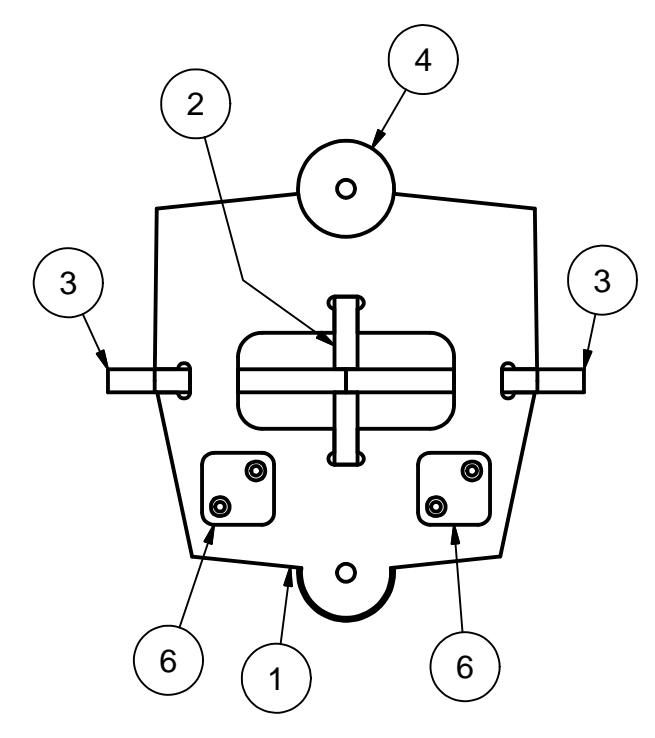

4 B21 FRAME - BOTTOM
 3"=1'-0"
 1 REQUIRED

Parts List			
ITEM	QTY	PART NUMBER	DESCRIPTION
7	1	Snake B22 B	SHEET SP2 VIEW 7
8	1	Snake B22 S	SHEET SP4 VIEW 8
9	2	Snake B22 R	SHEET SP6 VIEW 8
10	3	Snake Tab Hole	SHEET SP7 VIEW 1

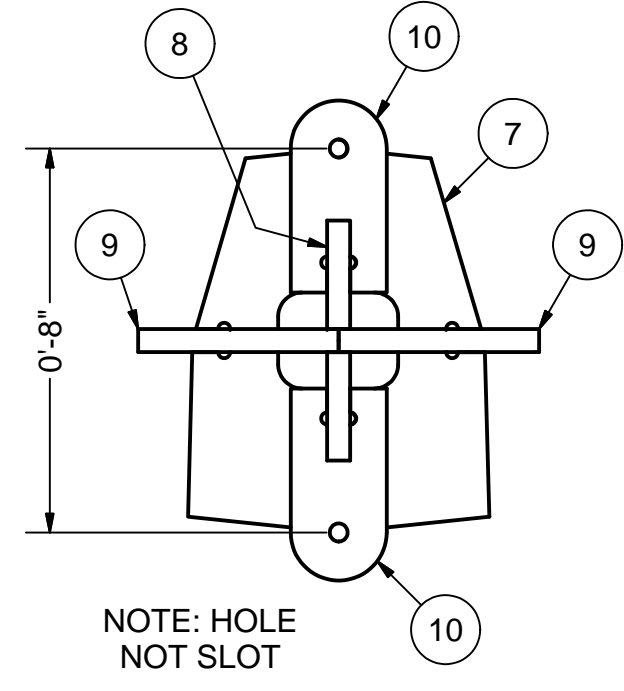

5 B22 FRAME - PLAN
 3"=1'-0"
 1 REQUIRED

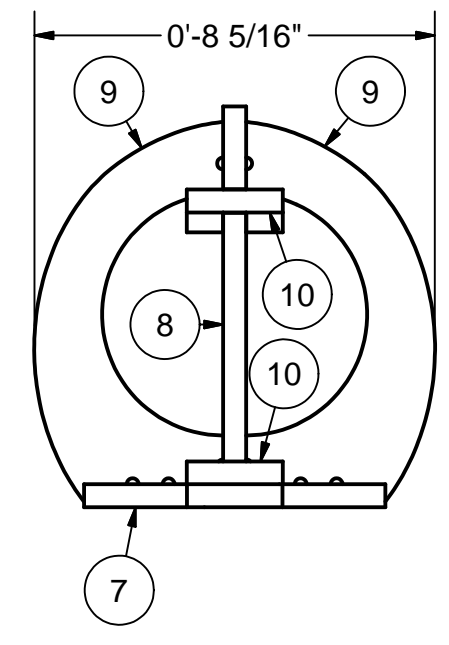

6 B22 FRAME - FACE
 3"=1'-0"
 1 REQUIRED

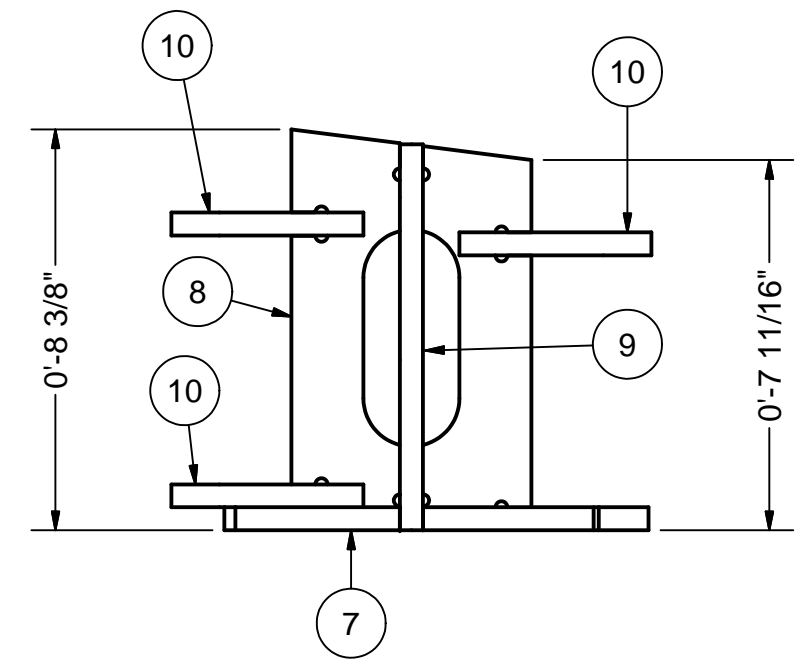

7 B22 FRAME - SIDE
 3"=1'-0"
 1 REQUIRED

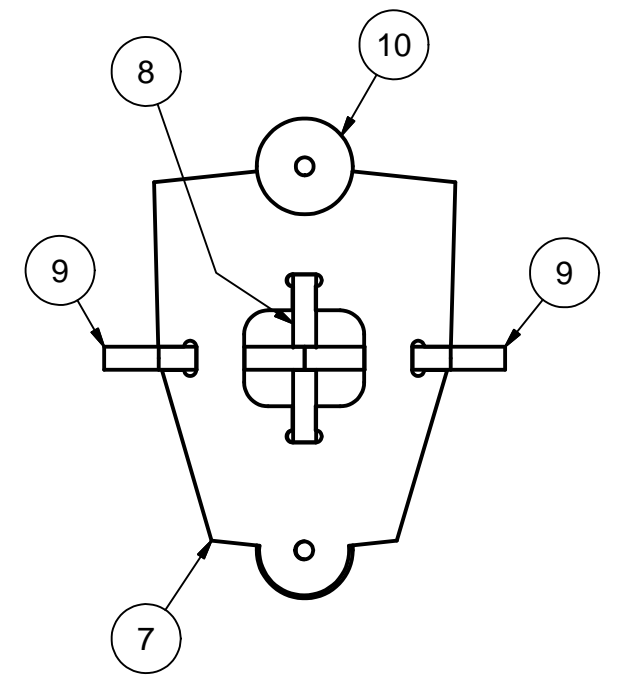

8 B22 FRAME - BOTTOM
 3"=1'-0"
 1 REQUIRED

REFERENCED	
FROM	TO

JOB ID: _____
 DRAWN BY: Ken Sly
 APPROVED BY: _____
 ORIGINAL DATE: 1/30/2012
 DUE DATE: _____
 SCALE: 3"=1'-0"

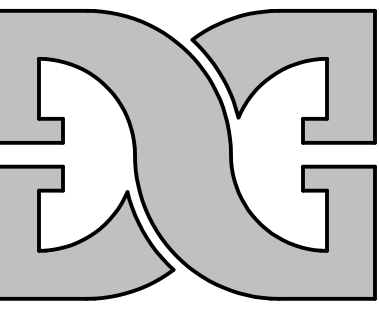

DIMENSIONAL GRAPHICS
 PHONE & FAX (650) 342-5724
 kensly@dimensionalgraphics.com
 www.dgflow.com
 MATERIAL CALLOUTS ARE TO CLARIFY THE DESIGN INTENT. ALL DESIGN CONCEPTS AND MATERIALS MUST BE VERIFIED BY A LICENSED ENGINEER.

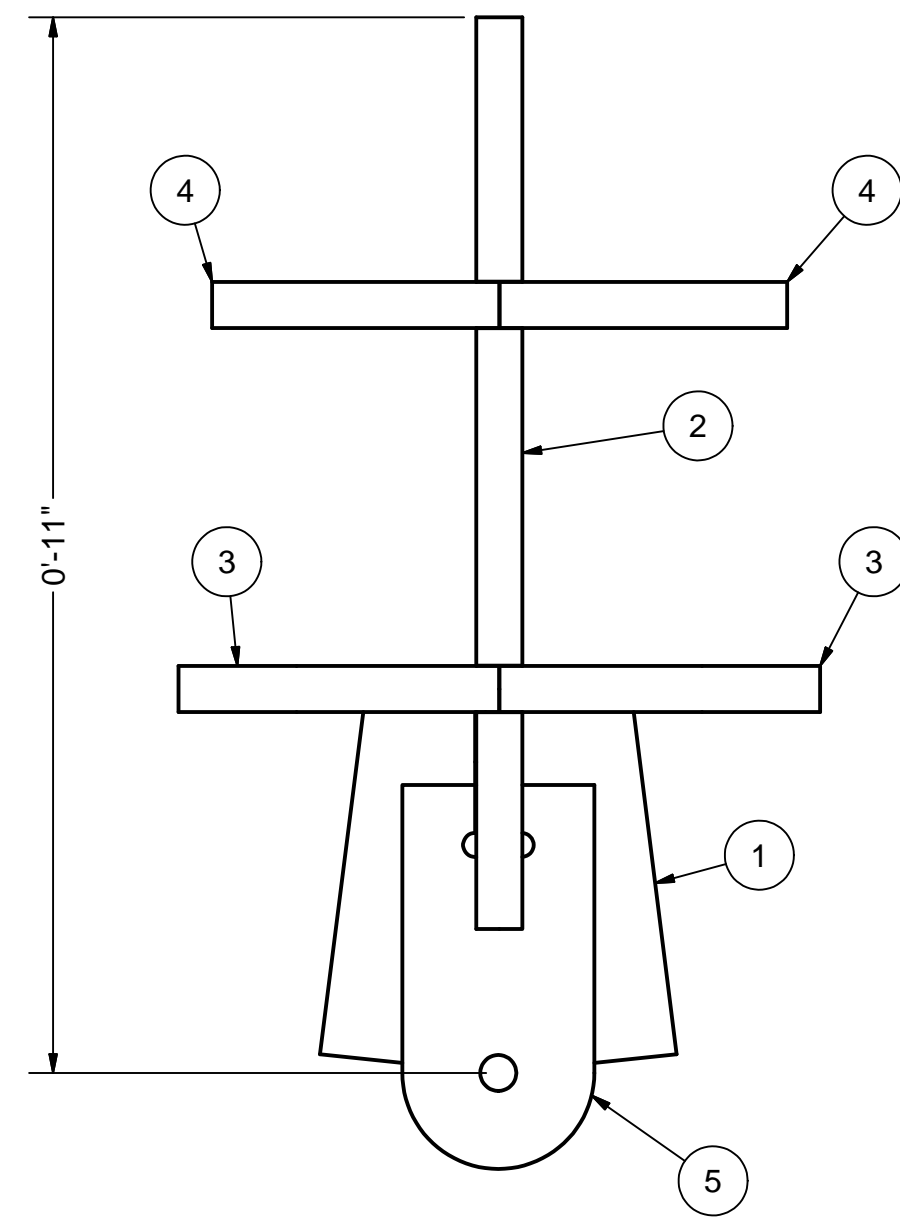

1 B23 FRAME - PLAN
 HALF SIZE
 1 REQUIRED

Parts List				
ITEM	QTY	PART NUMBER	DESCRIPTION	
1	1	Snake B23 B	SHEET SP2 VIEW 8	
2	1	Snake B23 S	SHEET SP4 VIEW 9	
3	2	Snake B23 R1	SHEET SP6 VIEW 9	
4	2	Snake B23 R2	SHEET SP6 VIEW 10	
5	2	Snake Tab Hole	SHEET SP7 VIEW 1	
6	1	Snake Slider	SHEET S7P VIEW 3-4	

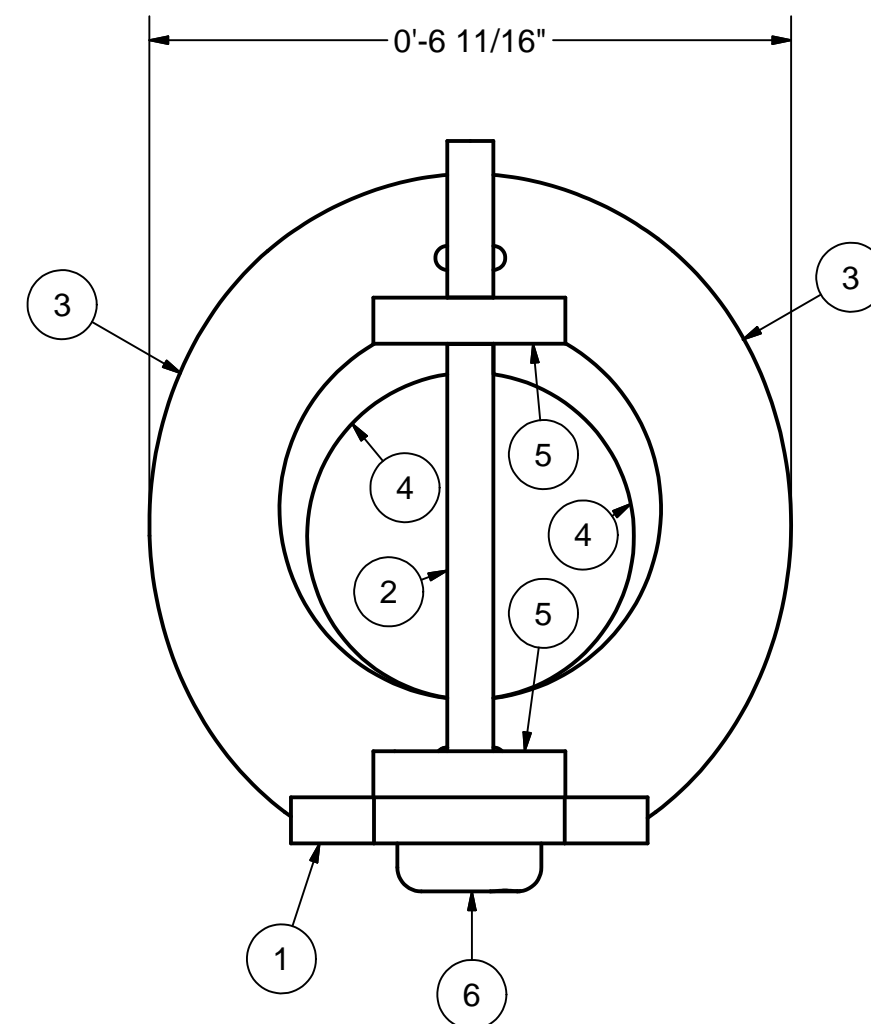

2 B23 FRAME - FACE
 HALF SIZE
 1 REQUIRED

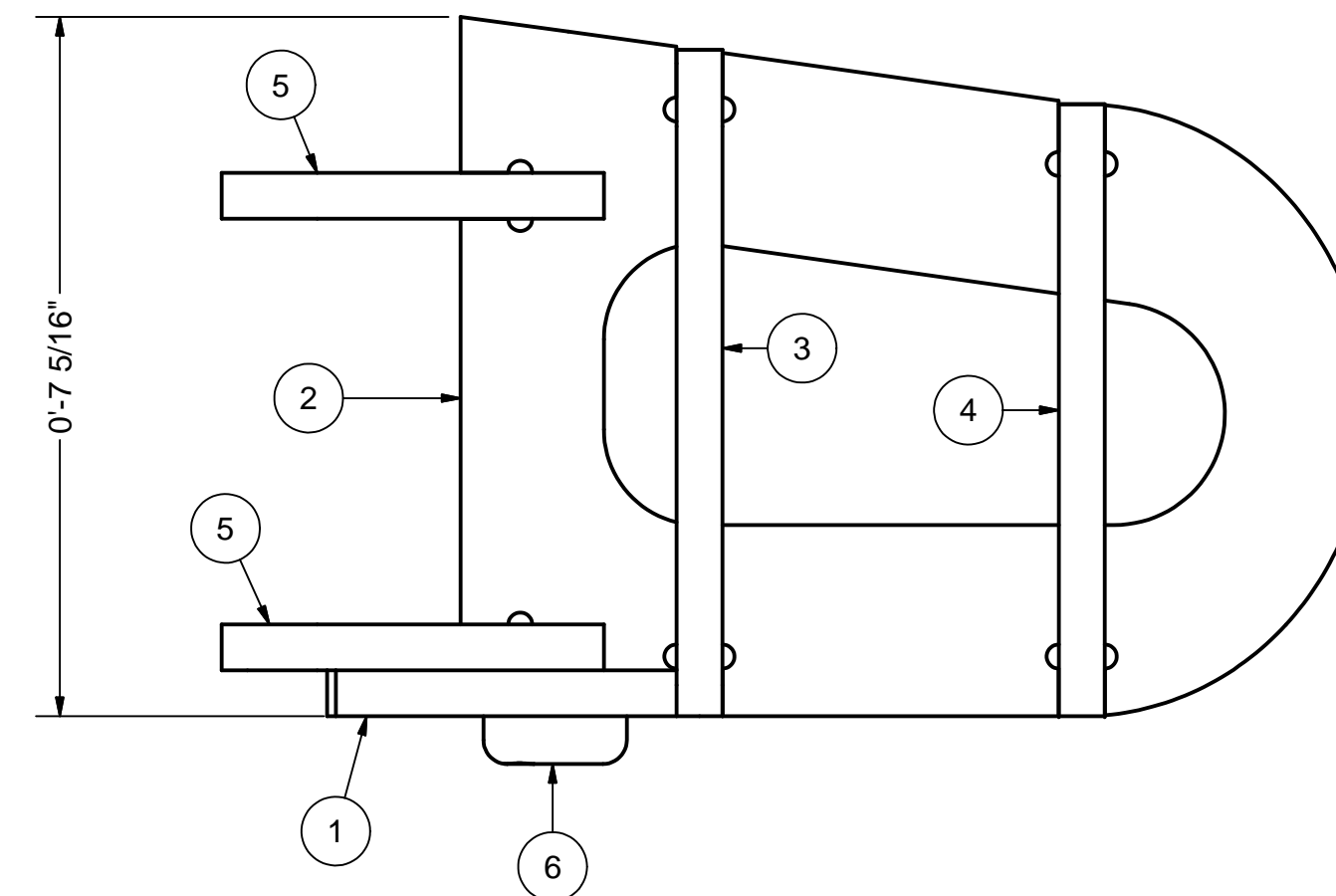

3 B23 FRAME - SIDE
 HALF SIZE
 1 REQUIRED

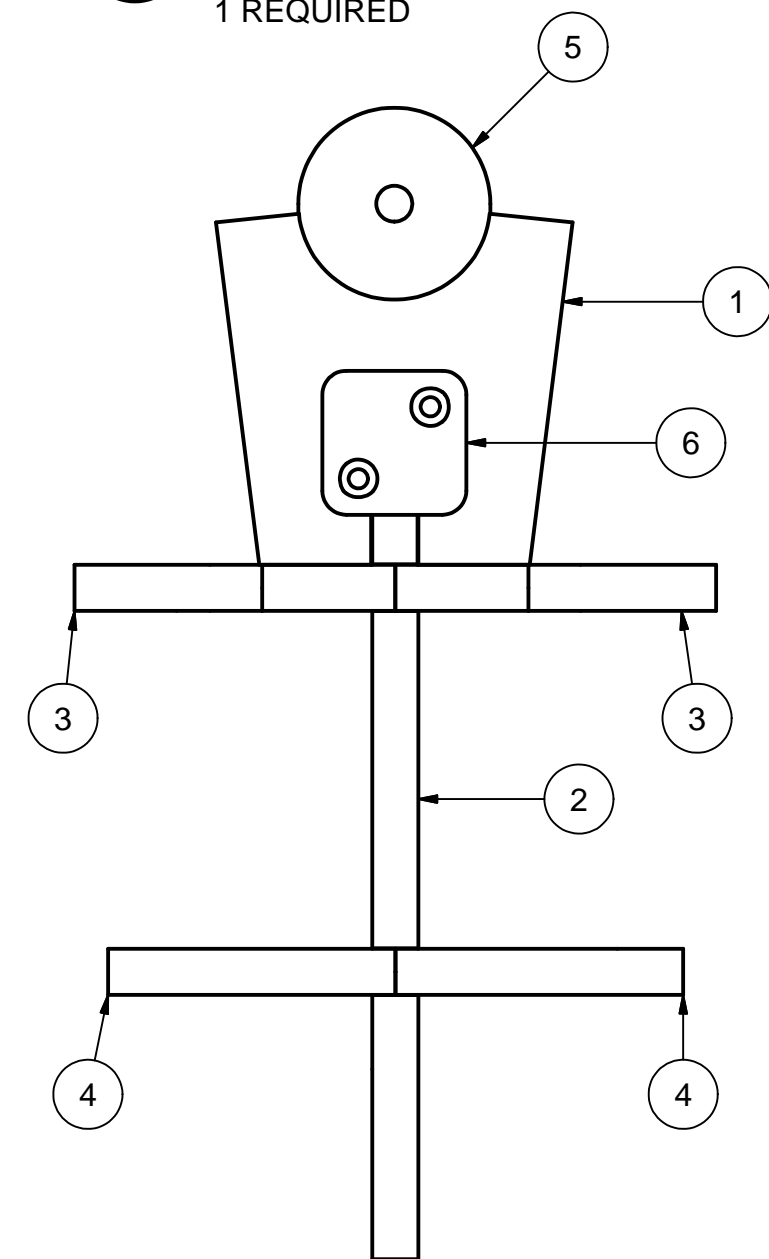

4 B23 FRAME - BOTTOM
 HALF SIZE
 1 REQUIRED

SNAKE BODY PART LAYOUTS
 SAN FRANCISCO OPERA
 MAGIC FLUTE 2012

REFERENCED	
FROM	TO

JOB ID: _____
 DRAWN BY: Ken Sly
 APPROVED BY: _____
 ORIGINAL DATE: 1/30/2012
 DUE DATE: _____
 SCALE: HALF SIZE
SB13
 LATEST REVISION: A

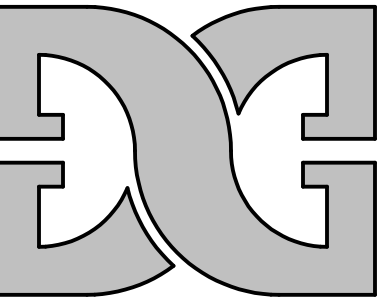

DIMENSIONAL GRAPHICS
 PHONE & FAX (650) 342-5724
 kensly@dgflow.com
 www.dgflow.com
 MATERIAL CALLOUTS ARE TO CLARIFY THE DESIGN INTENT. ALL DESIGN CONCEPTS AND MATERIALS MUST BE VERIFIED BY A LICENSED ENGINEER.

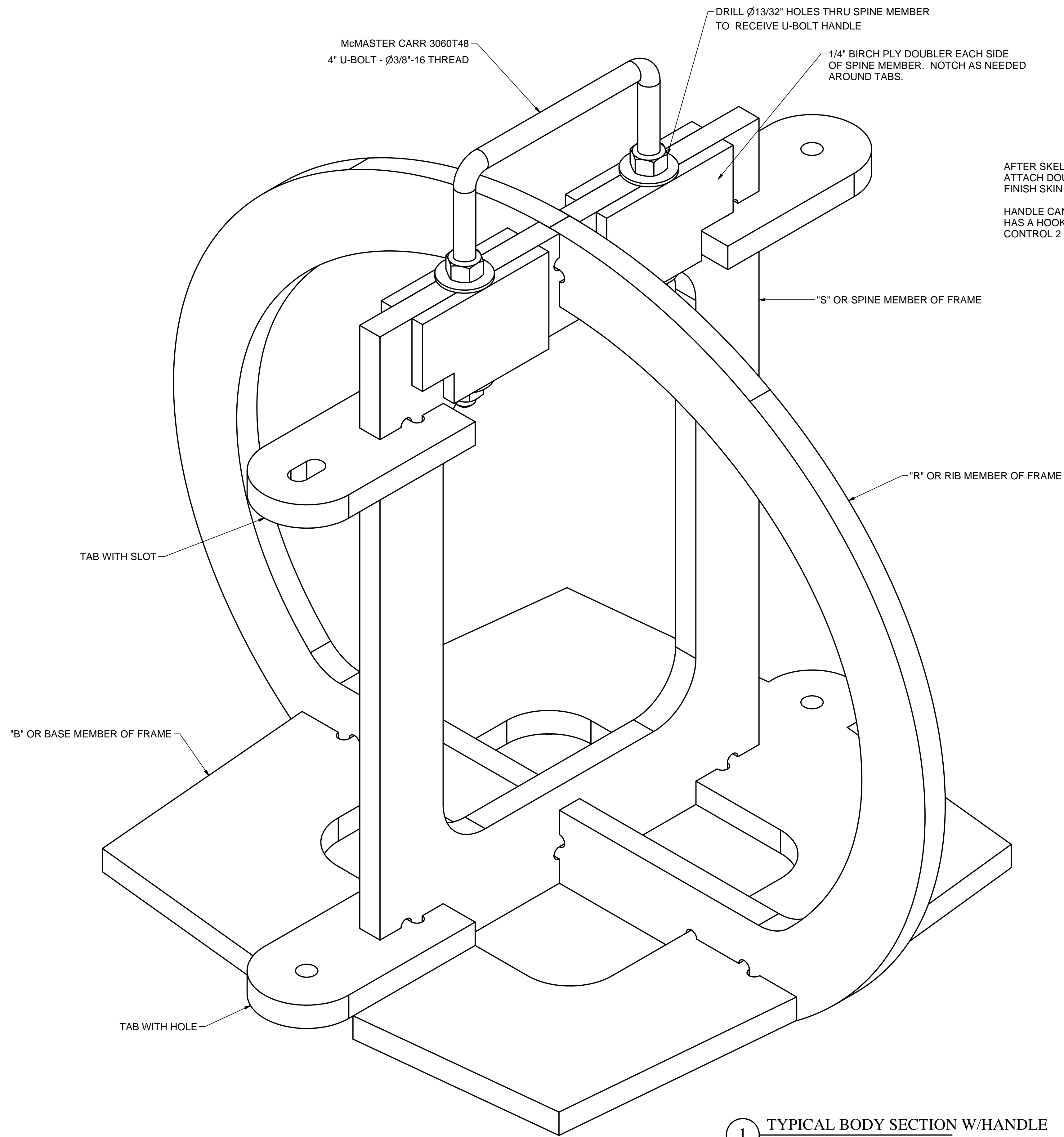

AFTER SKELETON IS ASSEMBLED, DETERMINE BEST LOCATIONS FOR HANDLES. ATTACH DOUBLERS AND PREDRILL THE SPINE MEMBER. AFTER 'SLIP SKIN' AND FINISH SKIN ARE APPLIED MOUNT U-BOLT HANDLES.

HANDLE CAN BE USED EITHER BY THE PUPPETEER'S HAND OR WITH A POLE THAT HAS A HOOK AT THE END. THE POLE OPTION WOULD ALLOW 1 PUPPETEER TO CONTROL 2 HANDLES AT A TIME - ONE BY HAND AND ONE BY POLE.

1 TYPICAL BODY SECTION W/HANDLE
 FULL SIZE

SNAKE BODY HANDLE OPTION 1
 SAN FRANCISCO OPERA
 MAGIC FLUTE 2012

REFERENCED	
FROM	TO

JOB ID: _____
 DRAWN BY: Ken Sly
 APPROVED BY: _____
 ORIGINAL DATE: 1/30/2012
 DUE DATE: _____
 SCALE: FULL SIZE

SB14
 LATEST REVISION **A**

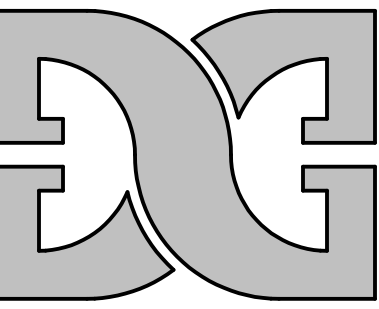

DIMENSIONAL GRAPHICS
 PHONE & FAX (650) 342-5724
 kensly@dimensionalgraphics.com
 www.dgflow.com
MATERIAL CALLOUTS ARE TO CLARIFY THE DESIGN INTENT. ALL DESIGN CONCEPTS AND MATERIALS MUST BE VERIFIED BY A LICENSED ENGINEER.

**SNAKE HEAD PATTERNS
 SAN FRANCISCO OPERA
 MAGIC FLUTE 2012**

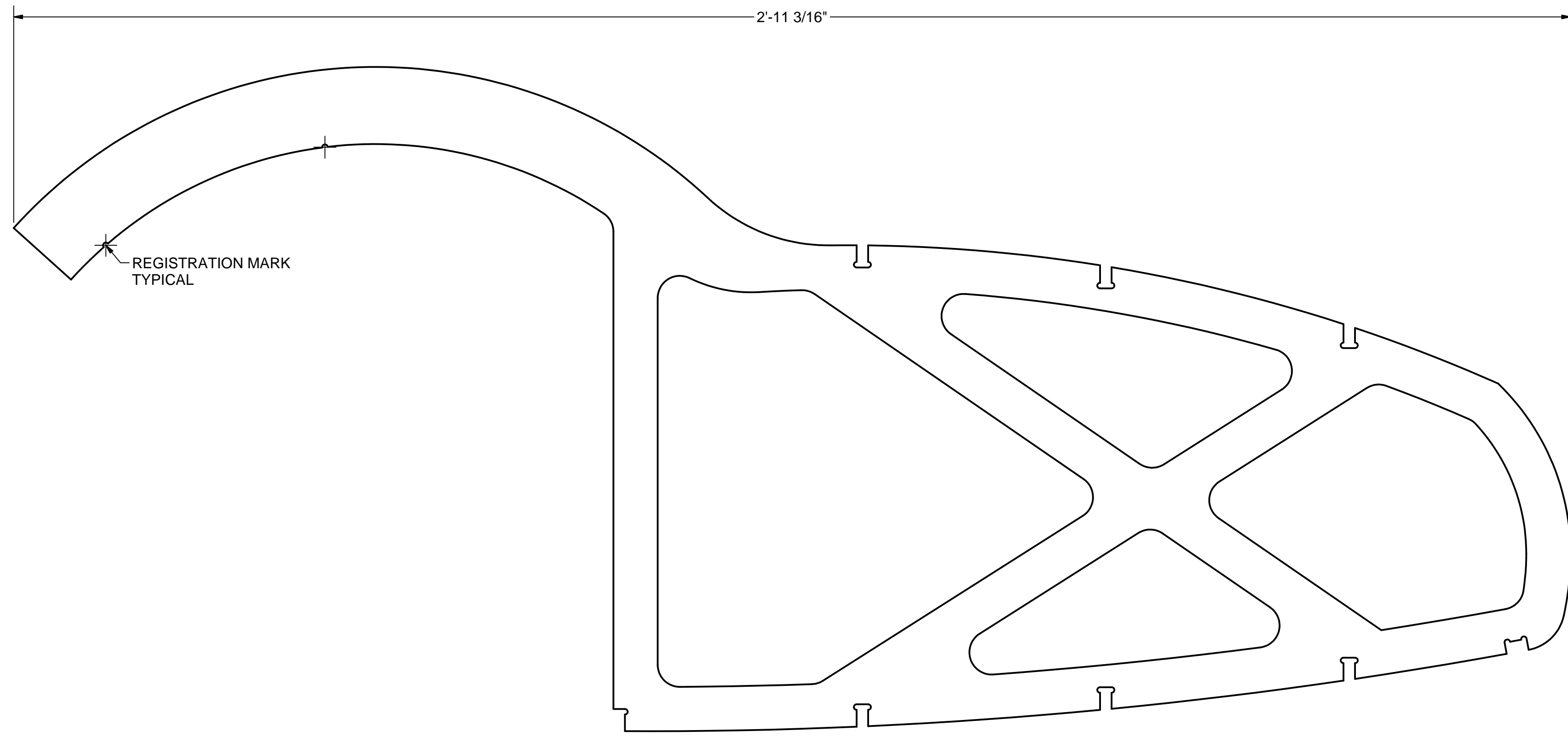

1 HEAD LONG1 - PATTERN
 HALF SIZE
 2 REQUIRED

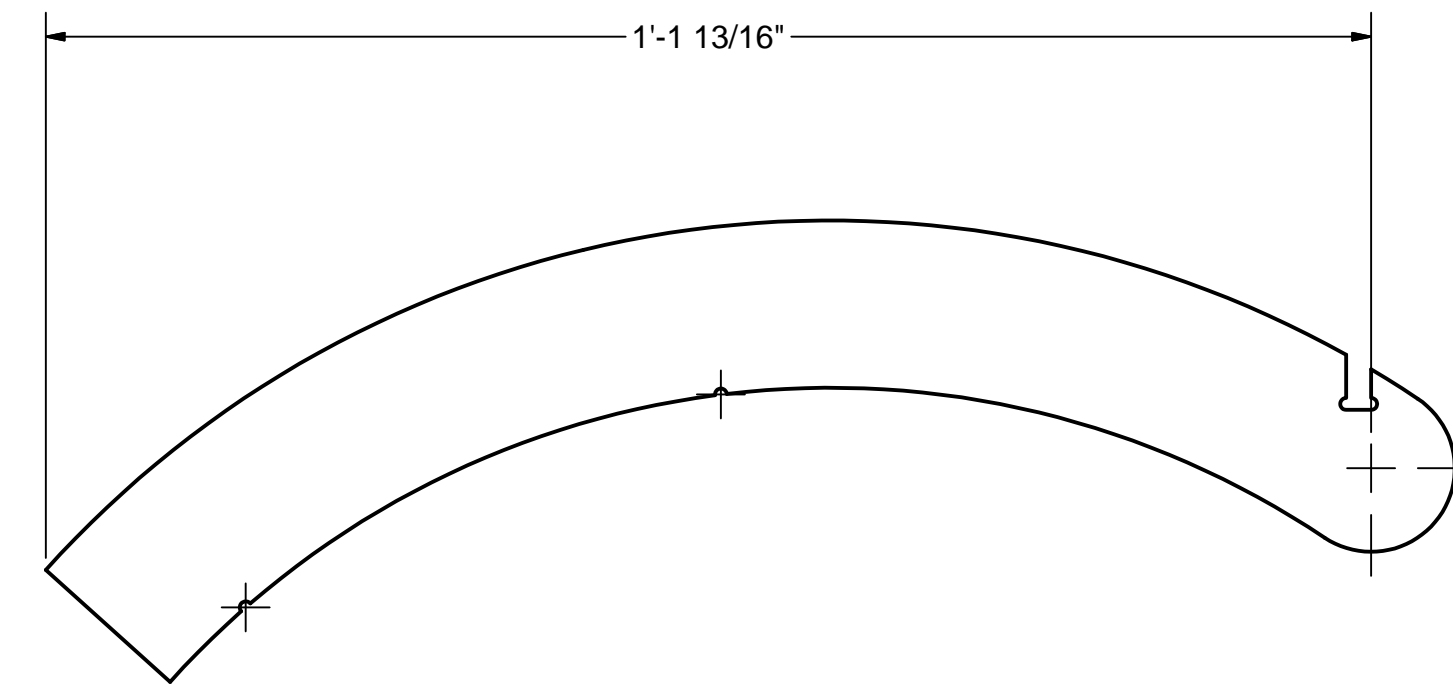

3 HEAD LONG2 - PATTERN
 HALF SIZE
 4 REQUIRED

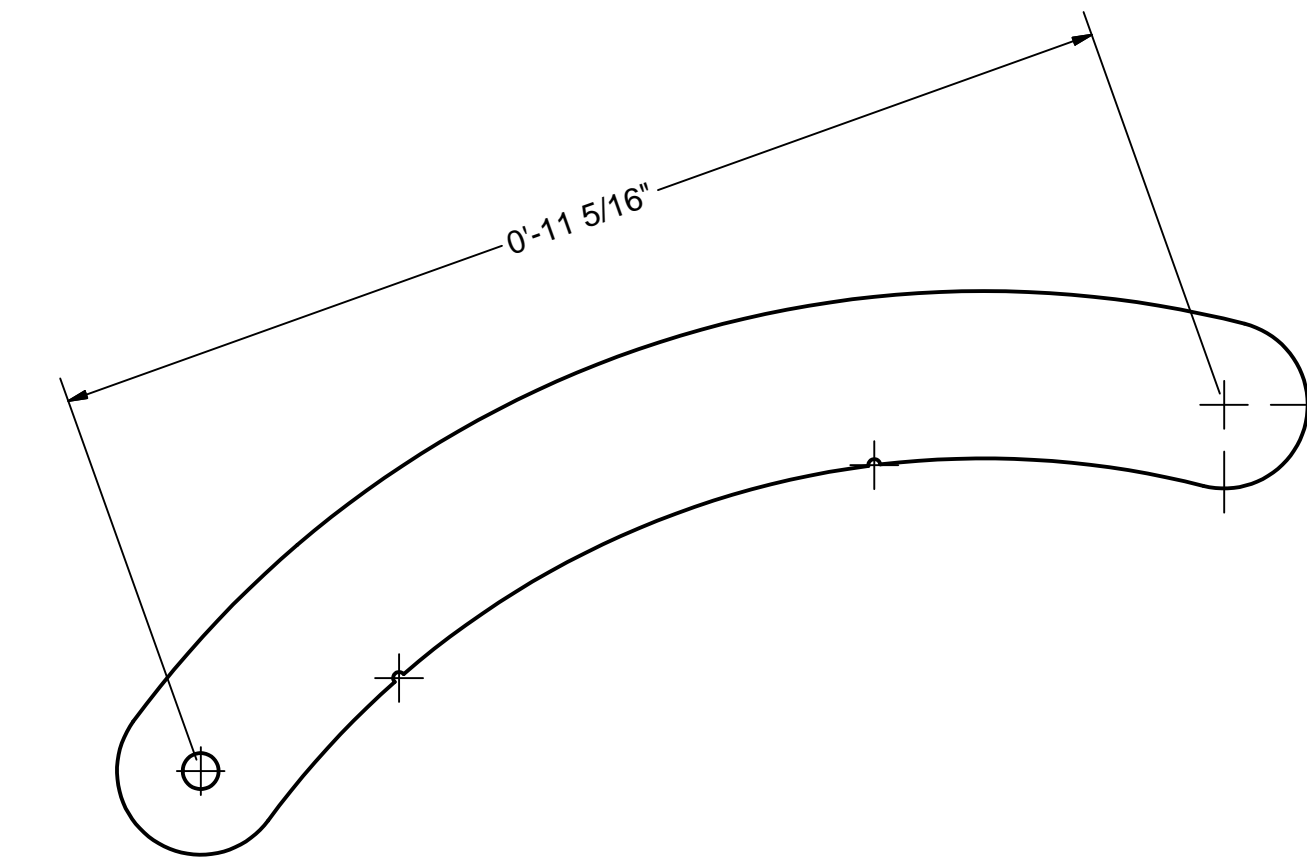

4 HEAD LONG3 - PATTERN
 HALF SIZE
 4 REQUIRED

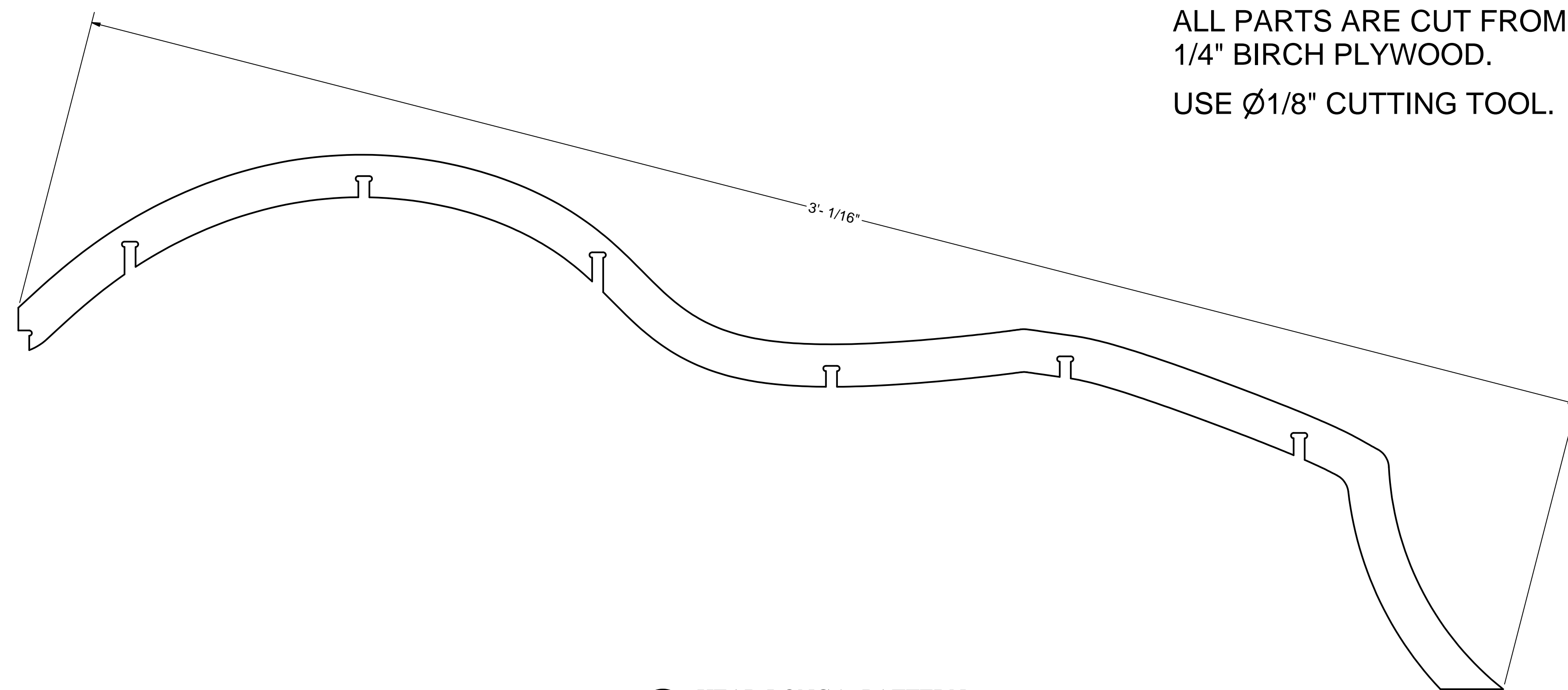

2 HEAD LONG5 - PATTERN
 HALF SIZE
 4 REQUIRED

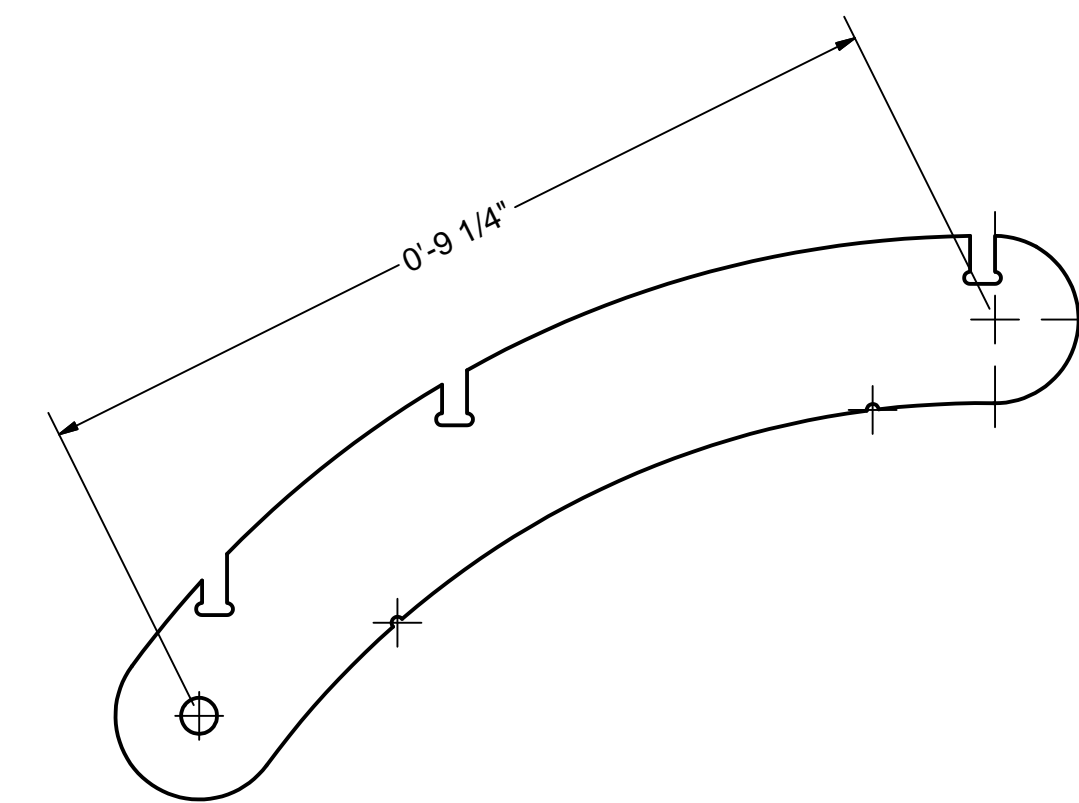

5 HEAD LONG4 - PATTERN
 HALF SIZE
 4 REQUIRED

**MATERIAL:
 ALL PARTS ARE CUT FROM
 1/4" BIRCH PLYWOOD.
 USE Ø1/8" CUTTING TOOL.**

REFERENCED	
FROM	TO

JOB ID: _____
 DRAWN BY: **Ken Sly**
 APPROVED BY: _____
 ORIGINAL DATE: **2/13/2012**
 DUE DATE: _____
 SCALE: **HALF SIZE**
SH1
LATEST REVISION

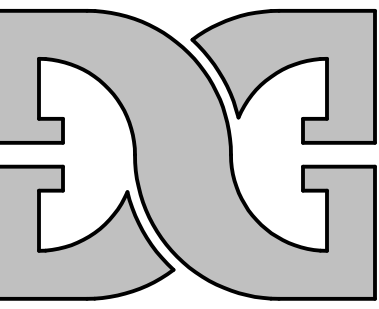

DIMENSIONAL GRAPHICS
 PHONE & FAX (650) 342-5724
 kensly@dimensionalgraphics.com
 www.dgslaw.com
MATERIAL CALLOUTS ARE TO CLARIFY THE DESIGN INTENT. ALL DESIGN CONCEPTS AND MATERIALS MUST BE VERIFIED BY A LICENSED ENGINEER.

SNAKE HEAD PATTERNS
SAN FRANCISCO OPERA
MAGIC FLUTE 2012

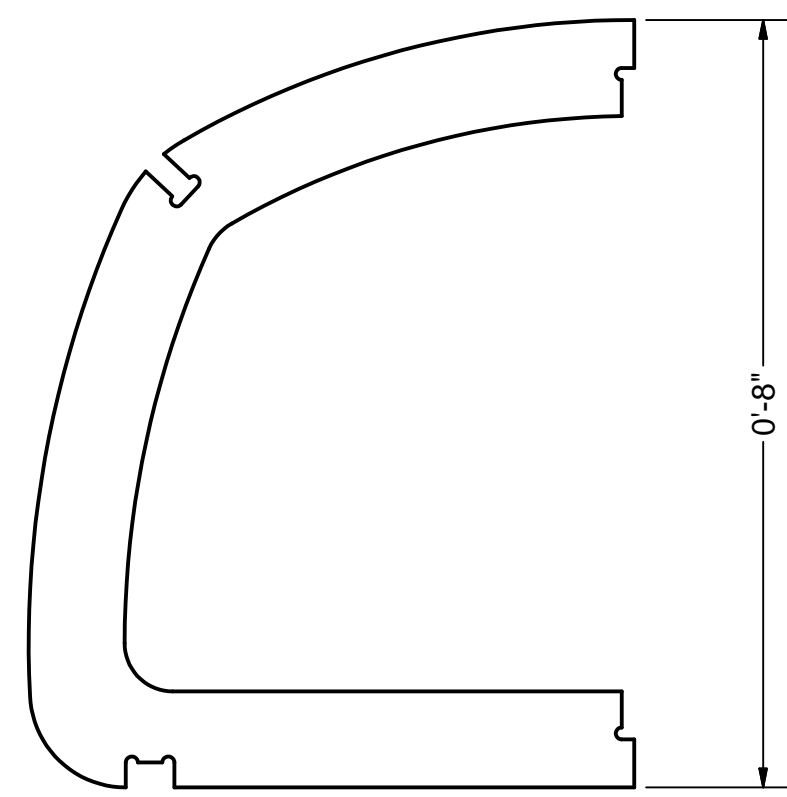

1 HEAD LAT1 - PATTERN
 HALF SIZE
 4 REQUIRED

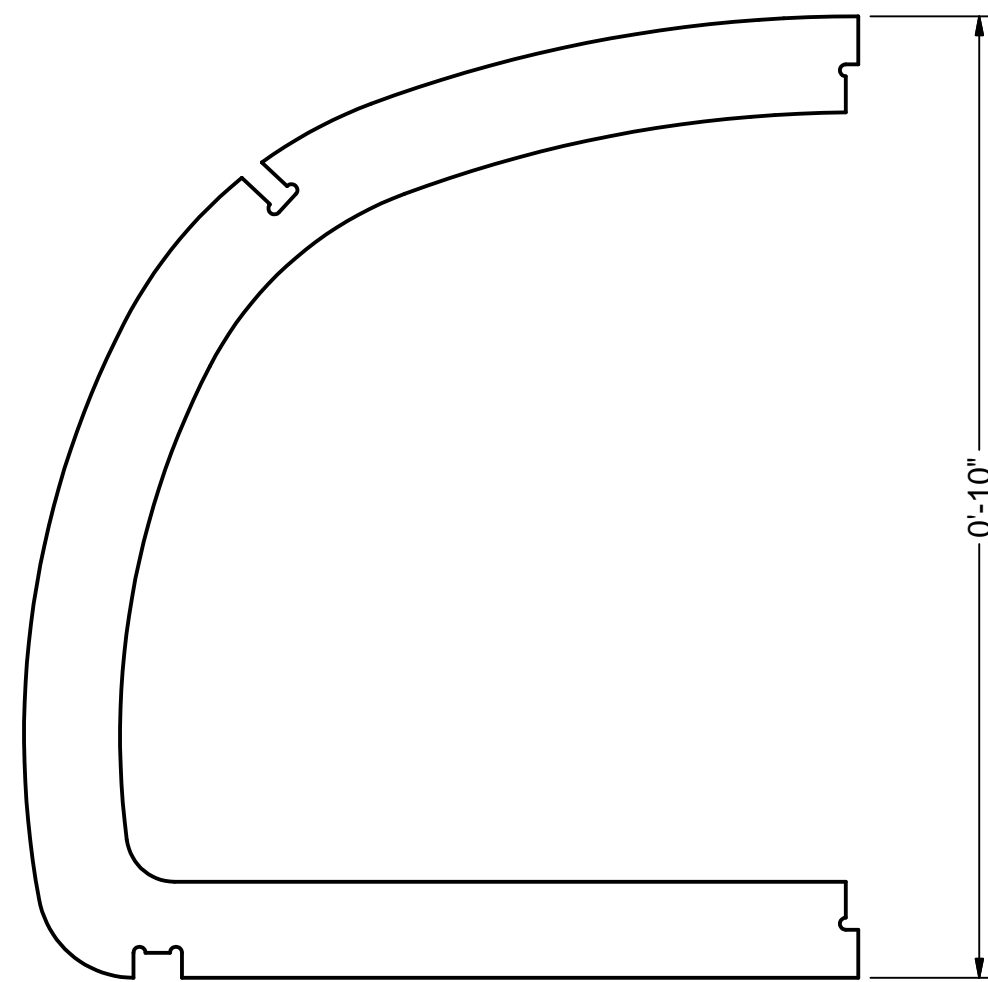

2 HEAD LAT2 - PATTERN
 HALF SIZE
 4 REQUIRED

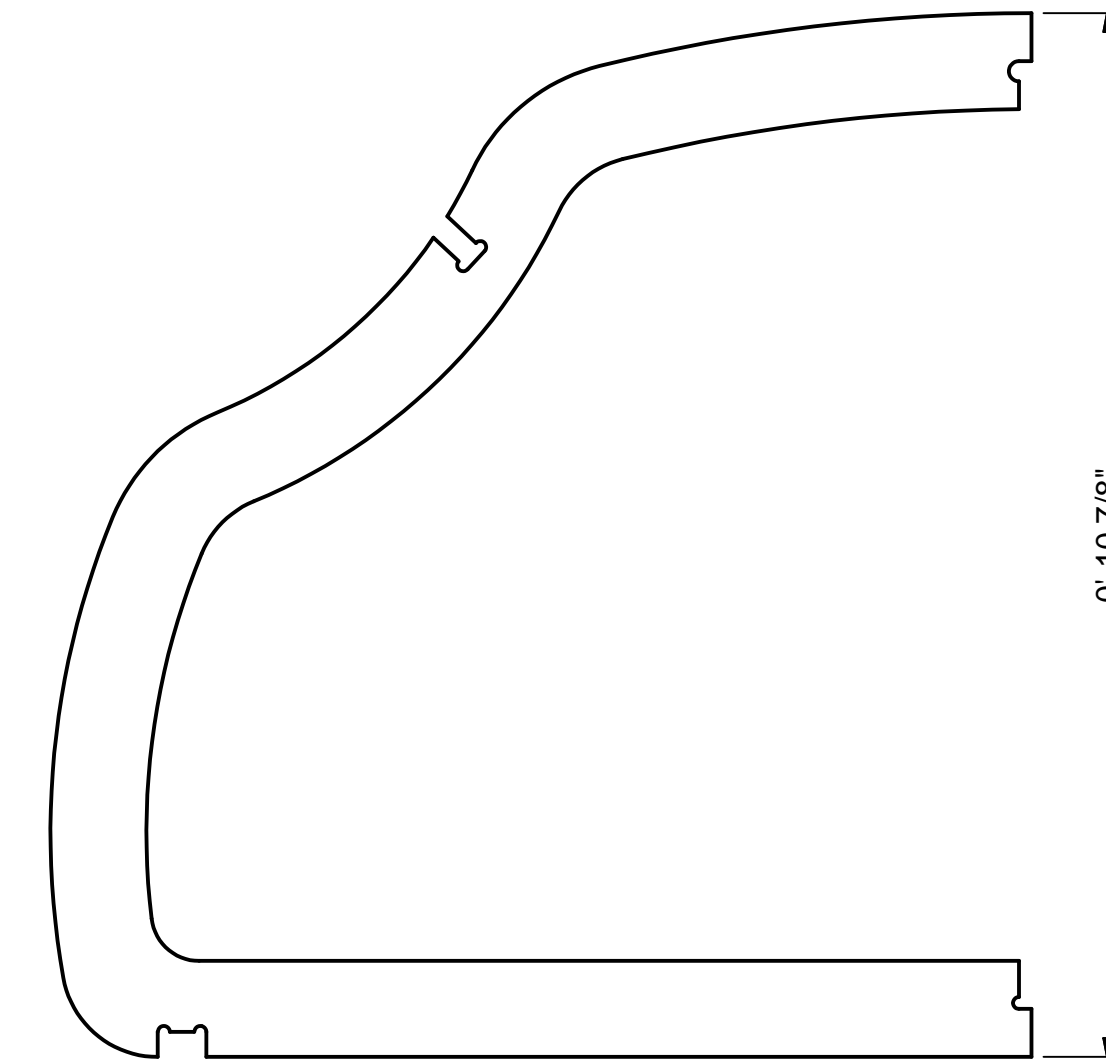

3 HEAD LAT3 - PATTERN
 HALF SIZE
 4 REQUIRED

MATERIAL:
 ALL PARTS ARE CUT FROM
 1/4" BIRCH PLYWOOD.
 USE Ø1/8" CUTTING TOOL.

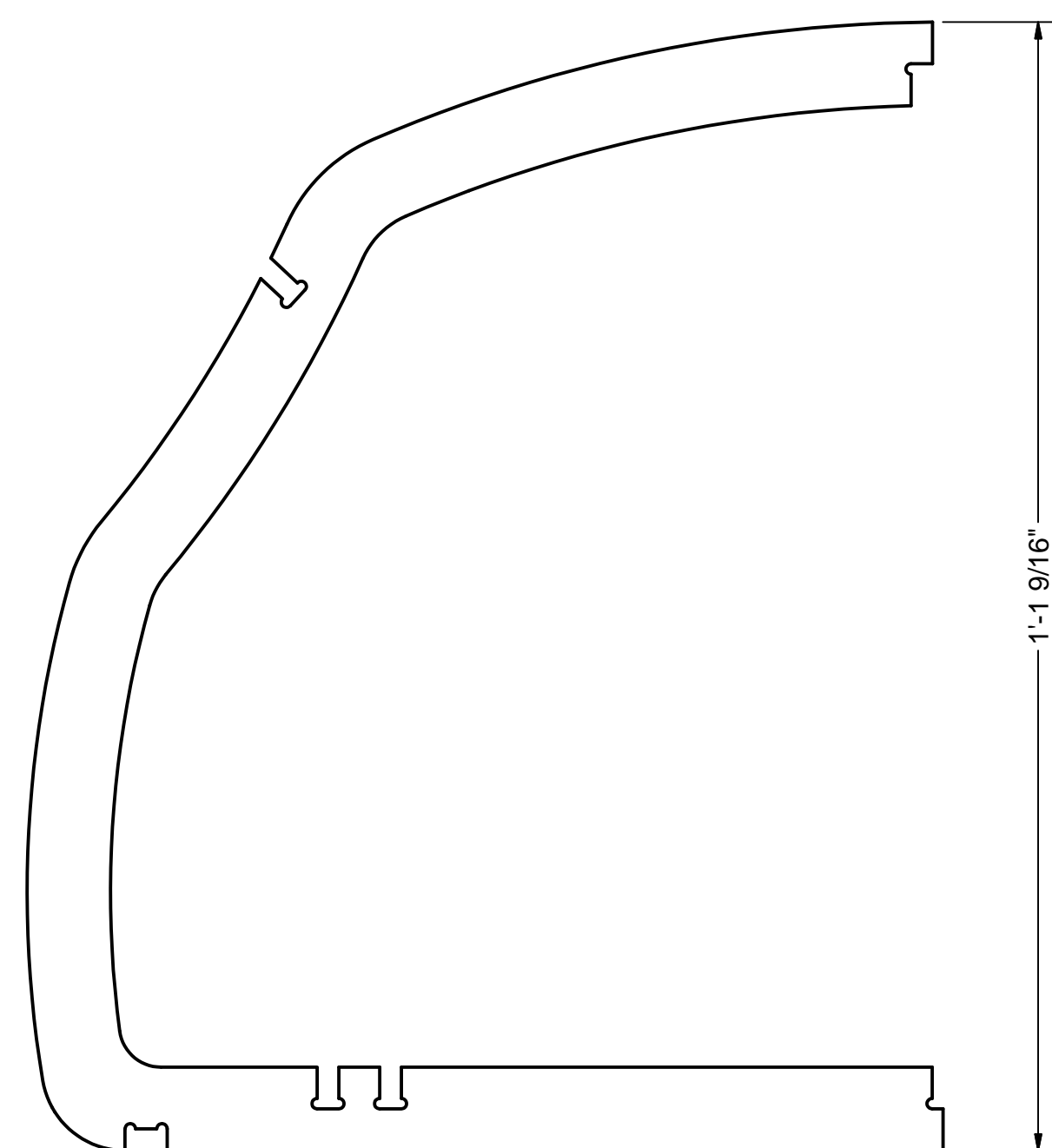

4 HEAD LAT4 - PATTERN
 HALF SIZE
 4 REQUIRED

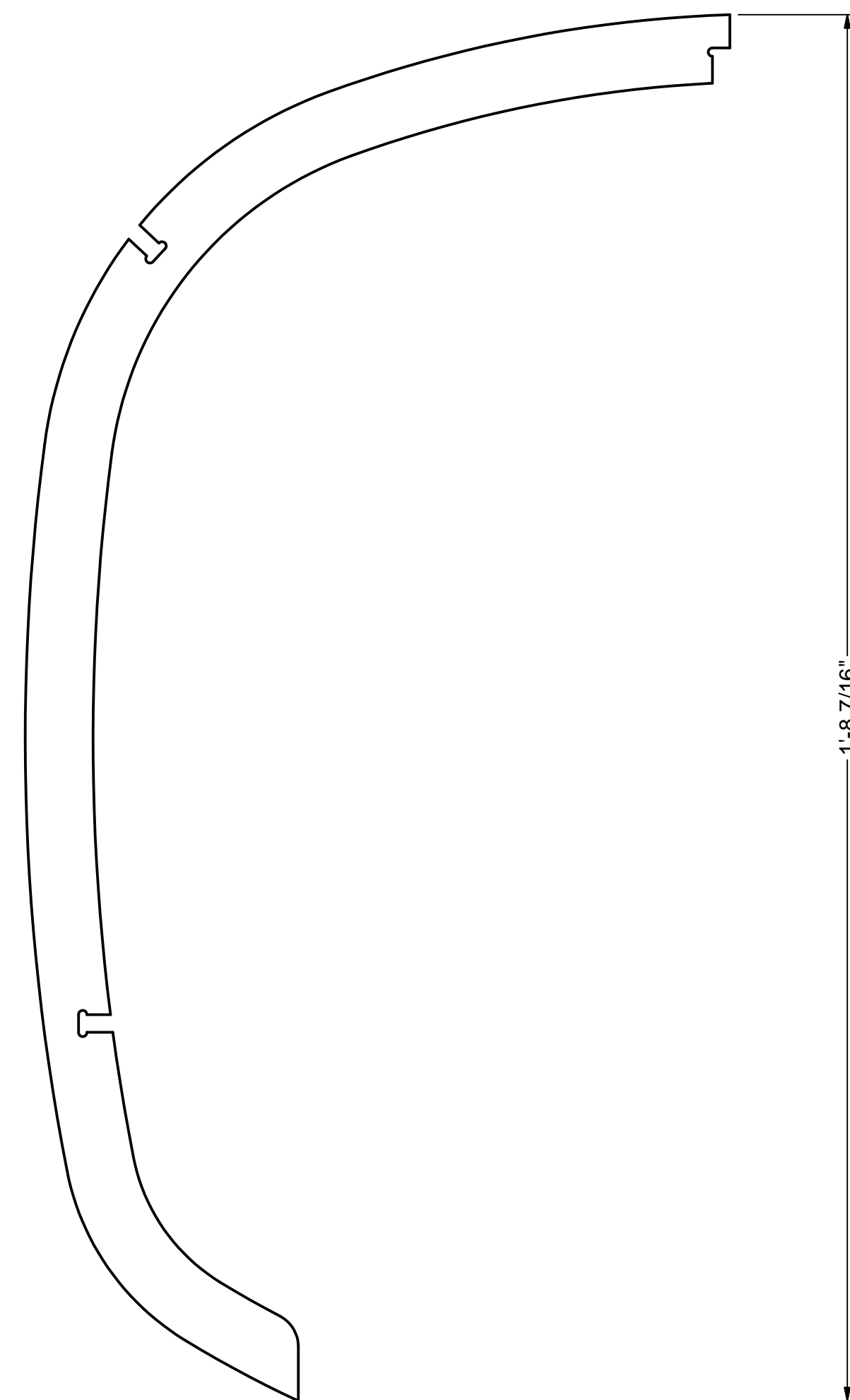

5 HEAD LAT5 - PATTERN
 HALF SIZE
 4 REQUIRED

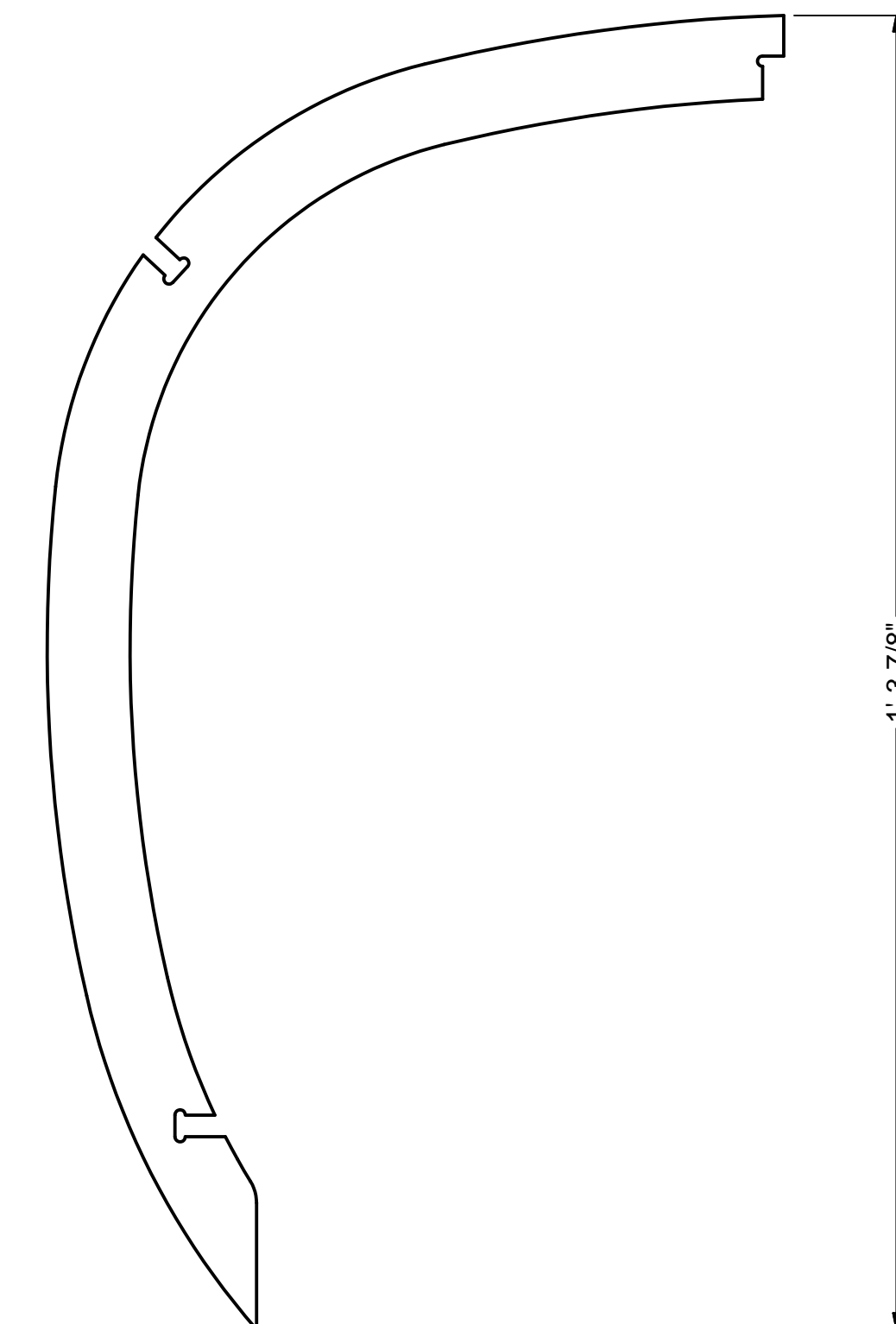

6 HEAD LAT6 - PATTERN
 HALF SIZE
 4 REQUIRED

REFERENCED	
FROM	TO

JOB ID: _____
 DRAWN BY: Ken Sly
 APPROVED BY: _____
 ORIGINAL DATE: 2/13/2012
 DUE DATE: _____
 SCALE: HALF SIZE
SH2
 LATEST REVISION A

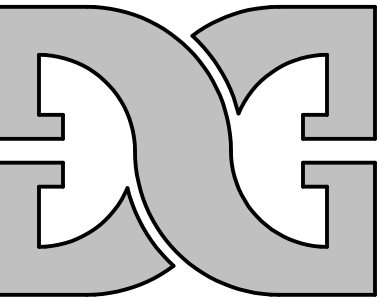

DIMENSIONAL GRAPHICS
 PHONE & FAX (650) 342-5724
 kensly@dimensionalgraphics.com
 www.dgflow.com
MATERIAL CALLOUTS ARE TO CLARIFY THE DESIGN INTENT. ALL DESIGN CONCEPTS AND MATERIALS MUST BE VERIFIED BY A LICENSED ENGINEER.

SNAKE HEAD PATTERNS
SAN FRANCISCO OPERA
MAGIC FLUTE 2012

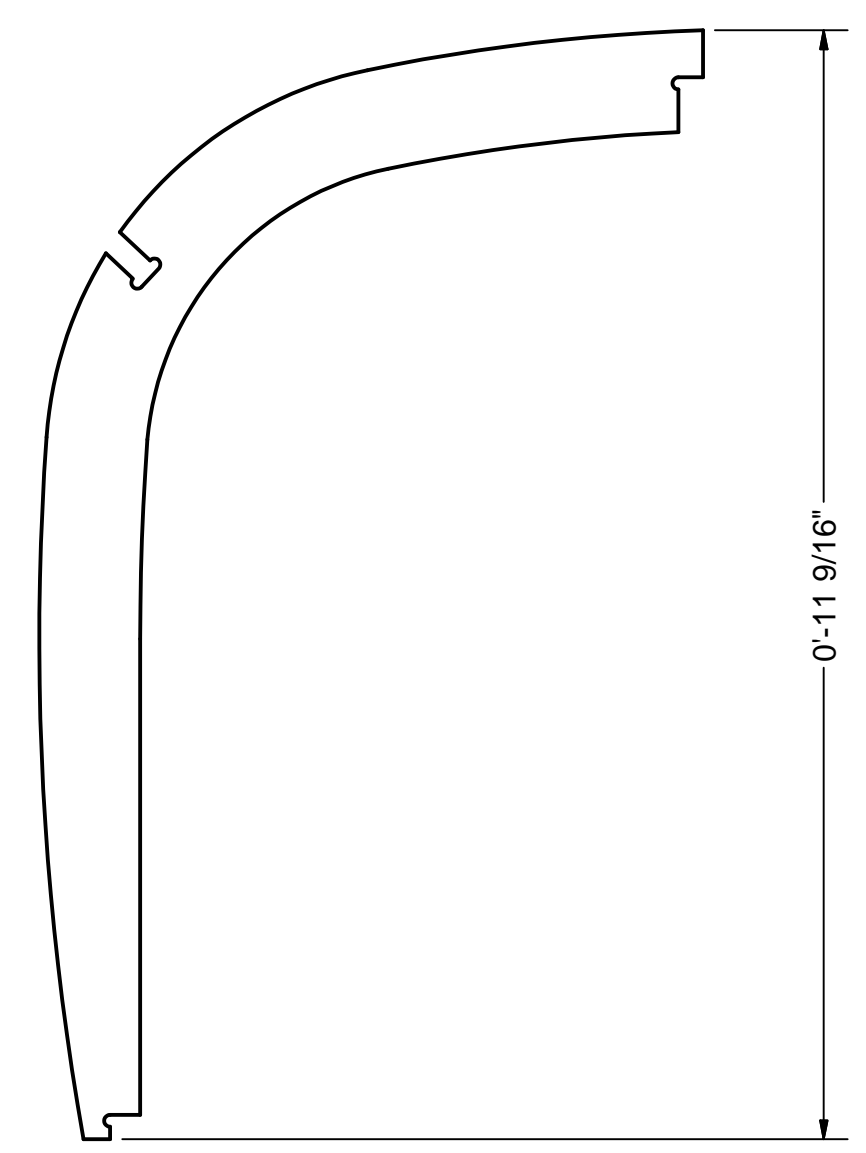

1 HEAD LAT7 - PATTERN
 HALF SIZE
 4 REQUIRED

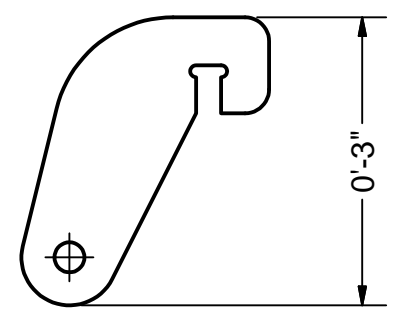

2 HEAD HINGE - PATTERN
 HALF SIZE
 8 REQUIRED

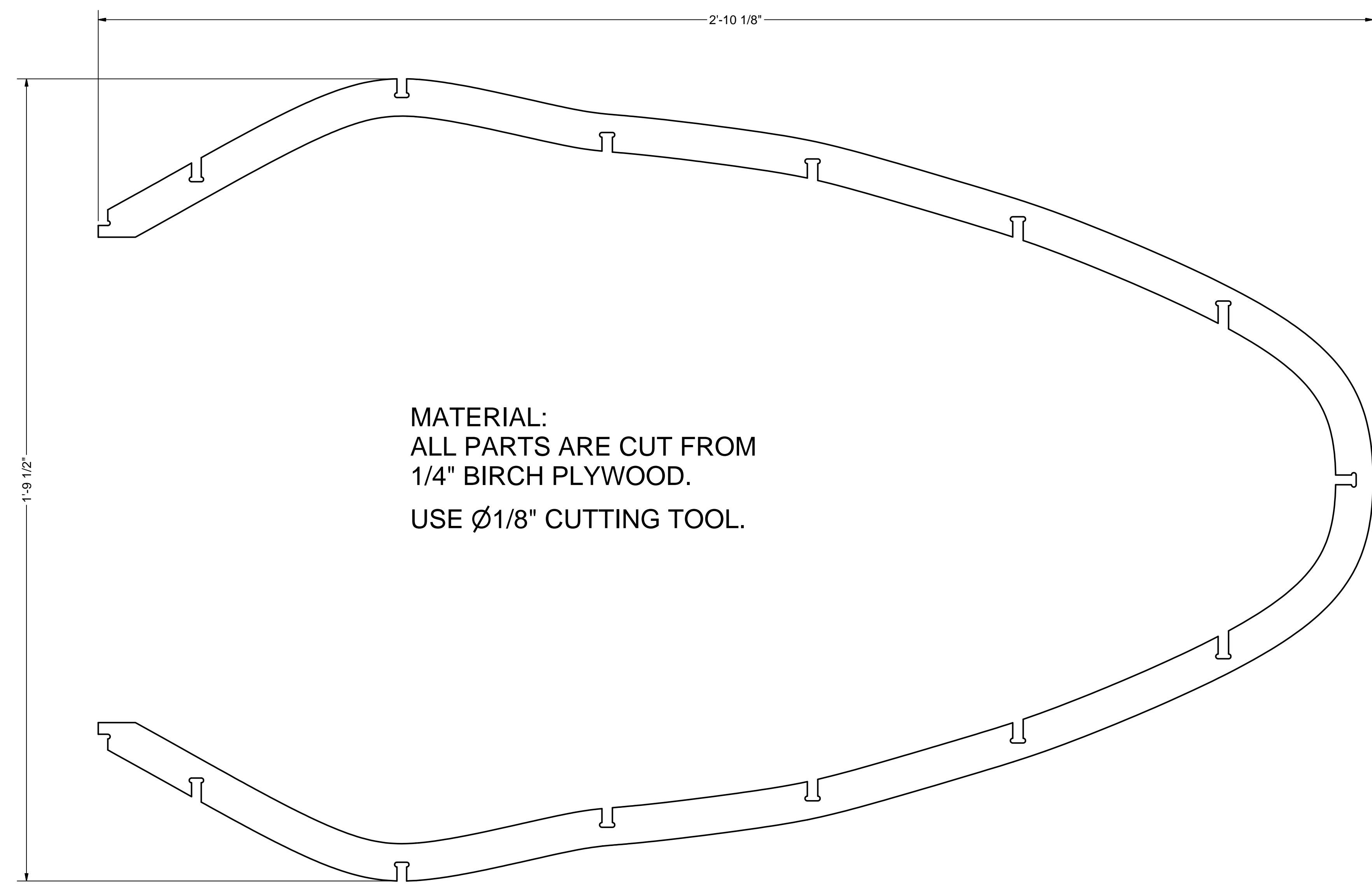

MATERIAL:
 ALL PARTS ARE CUT FROM
 1/4" BIRCH PLYWOOD.
 USE Ø1/8" CUTTING TOOL.

3 HEAD LIP TOP BENT - PATTERN
 HALF SIZE
 2 REQUIRED

REFERENCED	
FROM	TO

JOB ID: _____
 DRAWN BY: Ken Sly
 APPROVED BY: _____
 ORIGINAL DATE: 2/13/2012
 DUE DATE: _____
 SCALE: HALF SIZE
SH3
LATEST REVISION

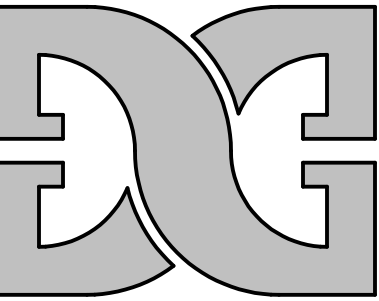

DIMENSIONAL GRAPHICS
 PHONE & FAX (650) 342-5724
 kensly@dimensionalgraphics.com
 www.dgflow.com
 MATERIAL CALLOUTS ARE TO CLARIFY THE DESIGN INTENT. ALL DESIGN CONCEPTS AND MATERIALS MUST BE VERIFIED BY A LICENSED ENGINEER.

SLAKE JAW PATTERNS
SAN FRANCISCO OPERA
MAGIC FLUTE 2012

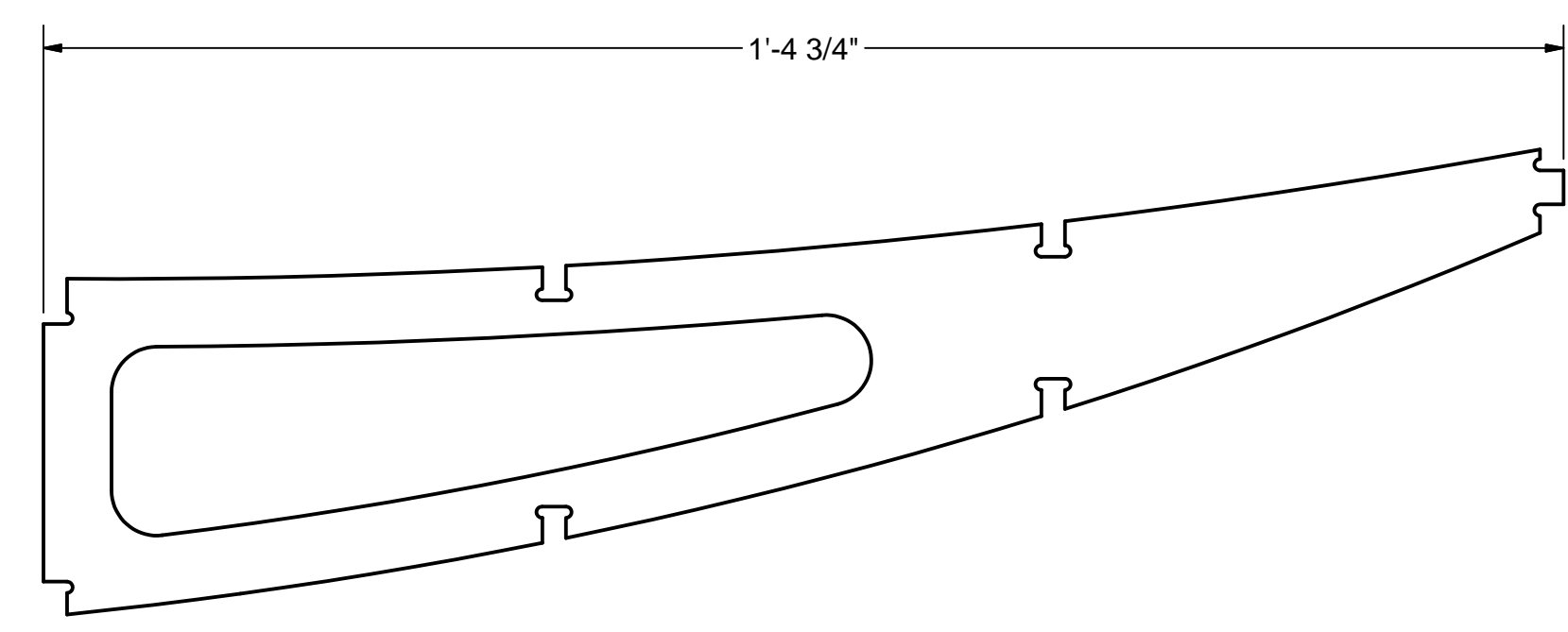

1 JAW L1 - PATTERN
 HALF SIZE
 2 REQUIRED

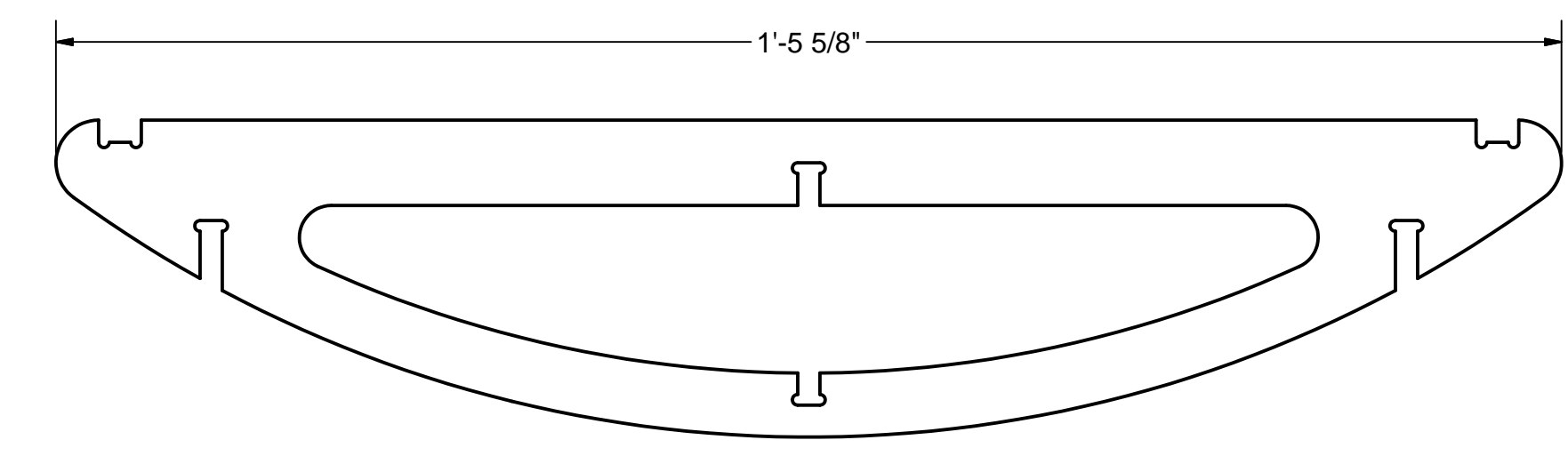

2 JAW R4 - PATTERN
 HALF SIZE
 2 REQUIRED

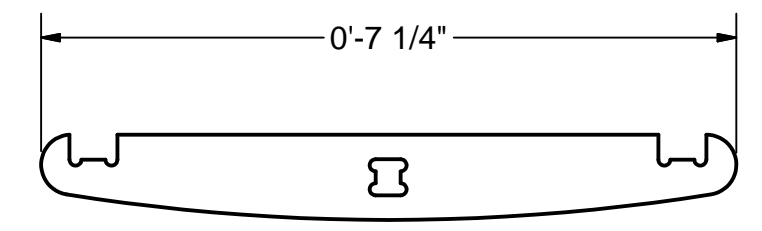

3 JAW R1 - PATTERN
 HALF SIZE
 2 REQUIRED

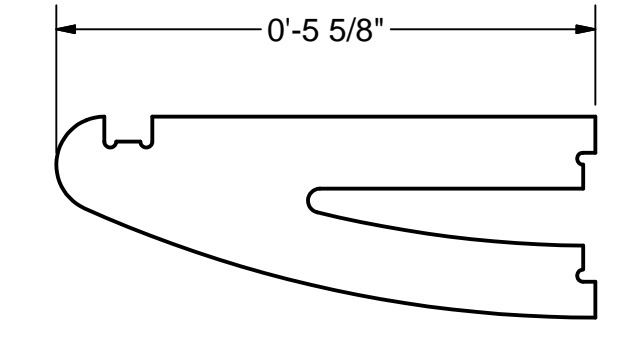

4 JAW R2 - PATTERN
 HALF SIZE
 4 REQUIRED

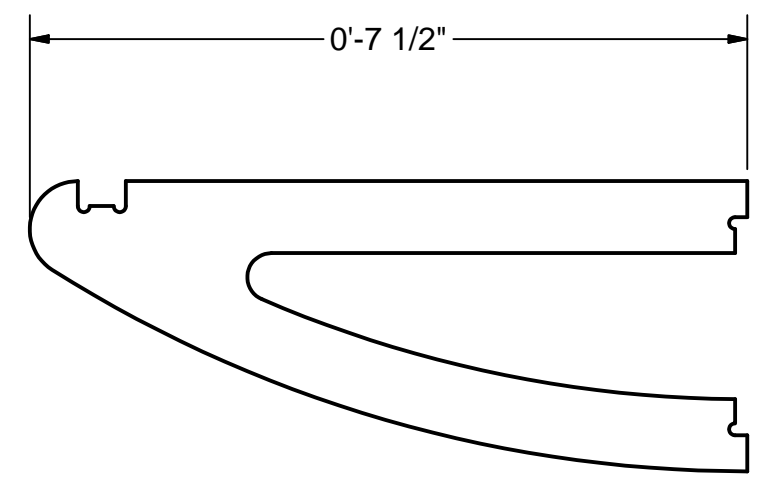

5 JAW R3 - PATTERN
 HALF SIZE
 4 REQUIRED

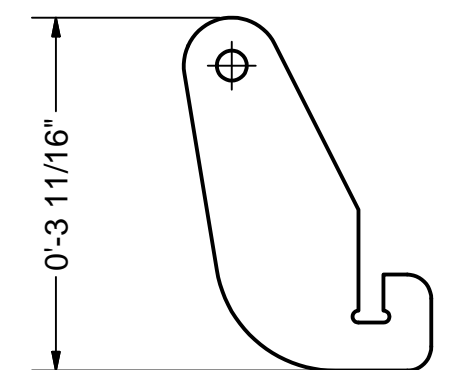

6 JAW HINGE - PATTERN
 HALF SIZE
 4 REQUIRED

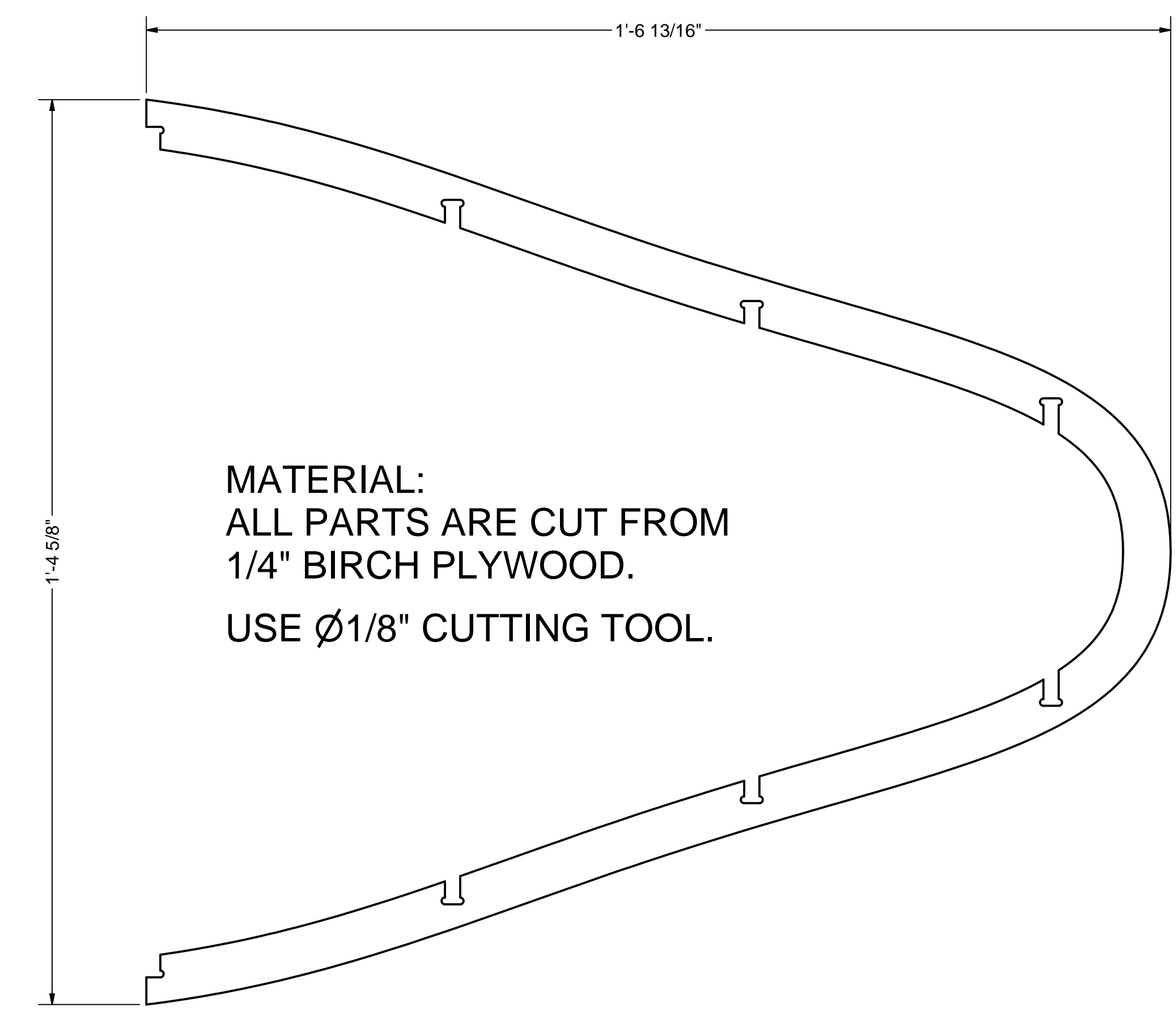

7 JAW LIP BENT - PATTERN
 HALF SIZE
 2 REQUIRED

REFERENCED	
FROM	TO

JOB ID: _____
 DRAWN BY: Ken Sly
 APPROVED BY: _____
 ORIGINAL DATE: 2/13/2012
 DUE DATE: _____
 SCALE: HALF SIZE
SH4
 LATEST REVISION **A**

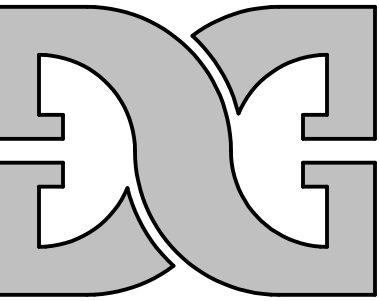

DIMENSIONAL GRAPHICS
 PHONE & FAX (650) 342-5724
 kensly@diglow.com
 www.diglow.com
MATERIAL CALLOUTS ARE TO CLARIFY THE DESIGN INTENT. ALL DESIGN CONCEPTS AND MATERIALS MUST BE VERIFIED BY A LICENSED ENGINEER.

SLAKE BODY TO NECK JOINT
SAN FRANCISCO OPERA
MAGIC FLUTE 2012

Parts List			
ITEM	QTY	PART NUMBER	DESCRIPTION
1	1	Snake Body Assm	SHEET SB1
2	2	Snake Neck Assm	SHEET SN1
3	4	Snake NRtrans	SHEET SP11 VIEW 1
4	2	Snake Head-Jaw assm	SHEET SL3

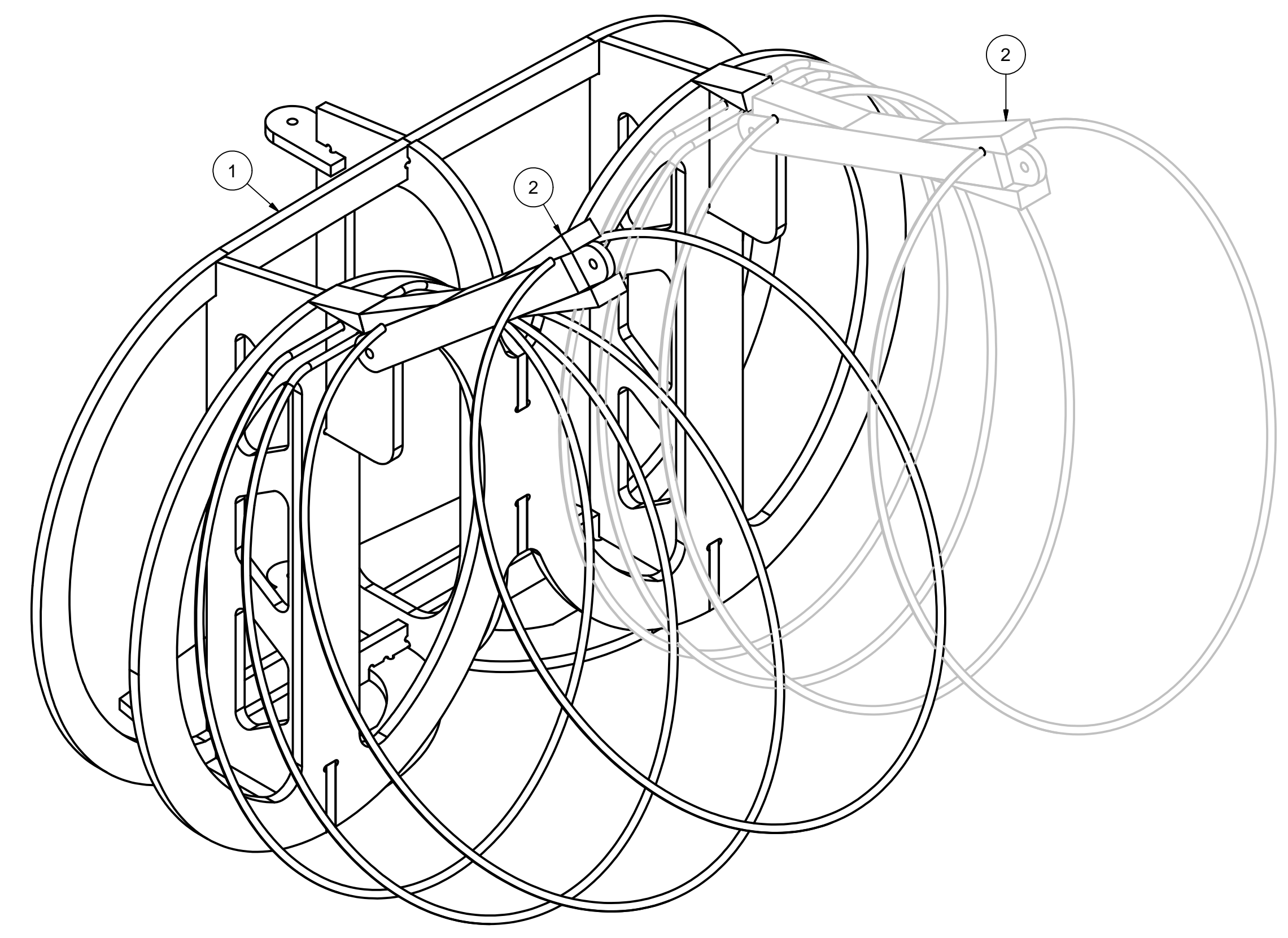

1 BODY-NECK JOINT - ISO
 3"=1'-0"

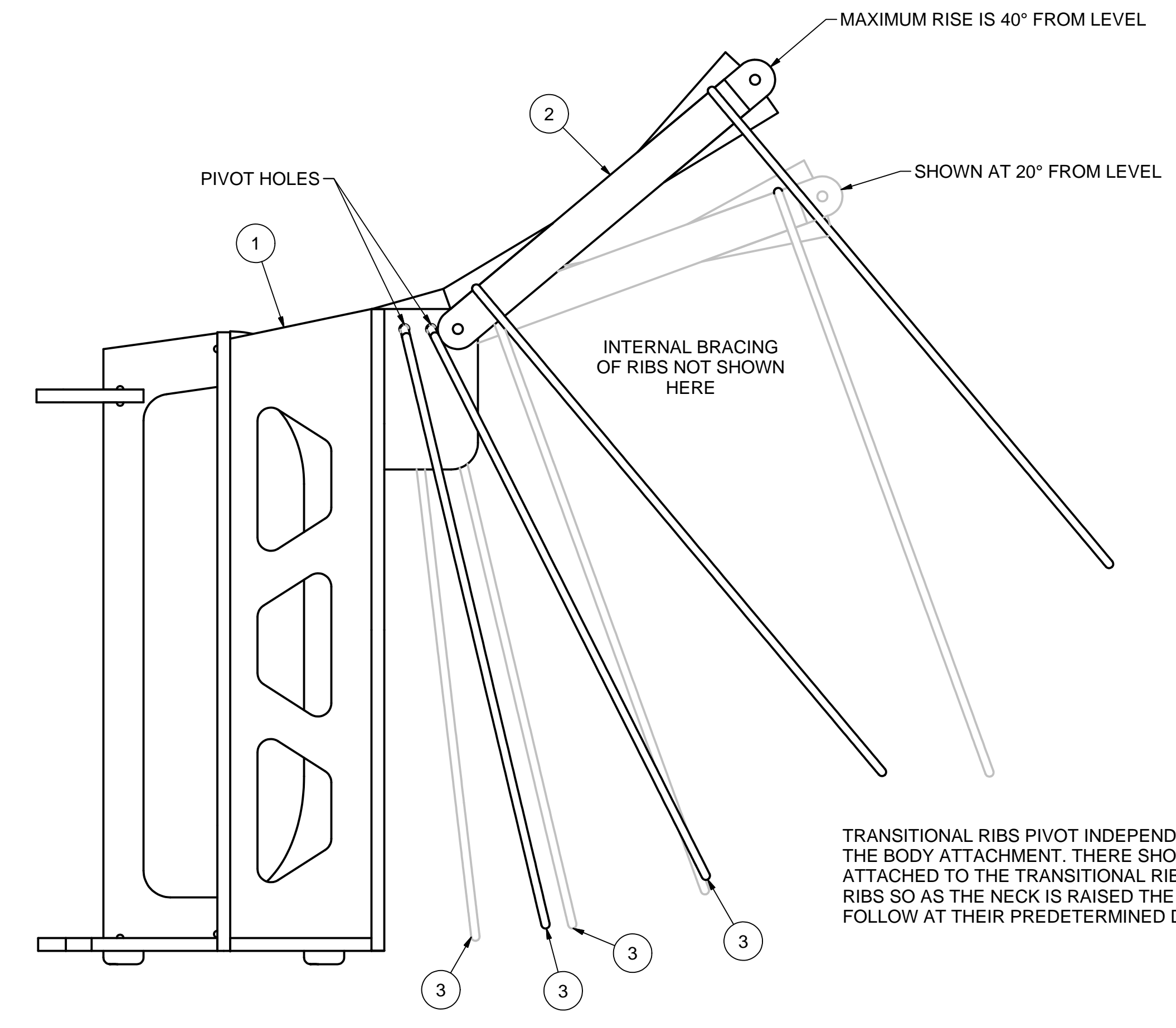

2 BODY-NECK JOINT - SIDE
 3"=1'-0"

TRANSITIONAL RIBS PIVOT INDEPENDANTLY IN THE HOLES IN THE BODY ATTACHMENT. THERE SHOULD BE WEBBING ATTACHED TO THE TRANSITIONAL RIBS AND THE FIRST NECK RIBS SO AS THE NECK IS RAISED THE TRANSITIONAL RIBS FOLLOW AT THEIR PREDETERMINED DISTANCES.

INTENTIONAL SLOP IN THE NECK JOINTS ALLOW FOR SOME SIDE TO SIDE MOVEMENT OF THE NECK AS WELL AS THE PIVOTING OF THE NECK SECTIONS.

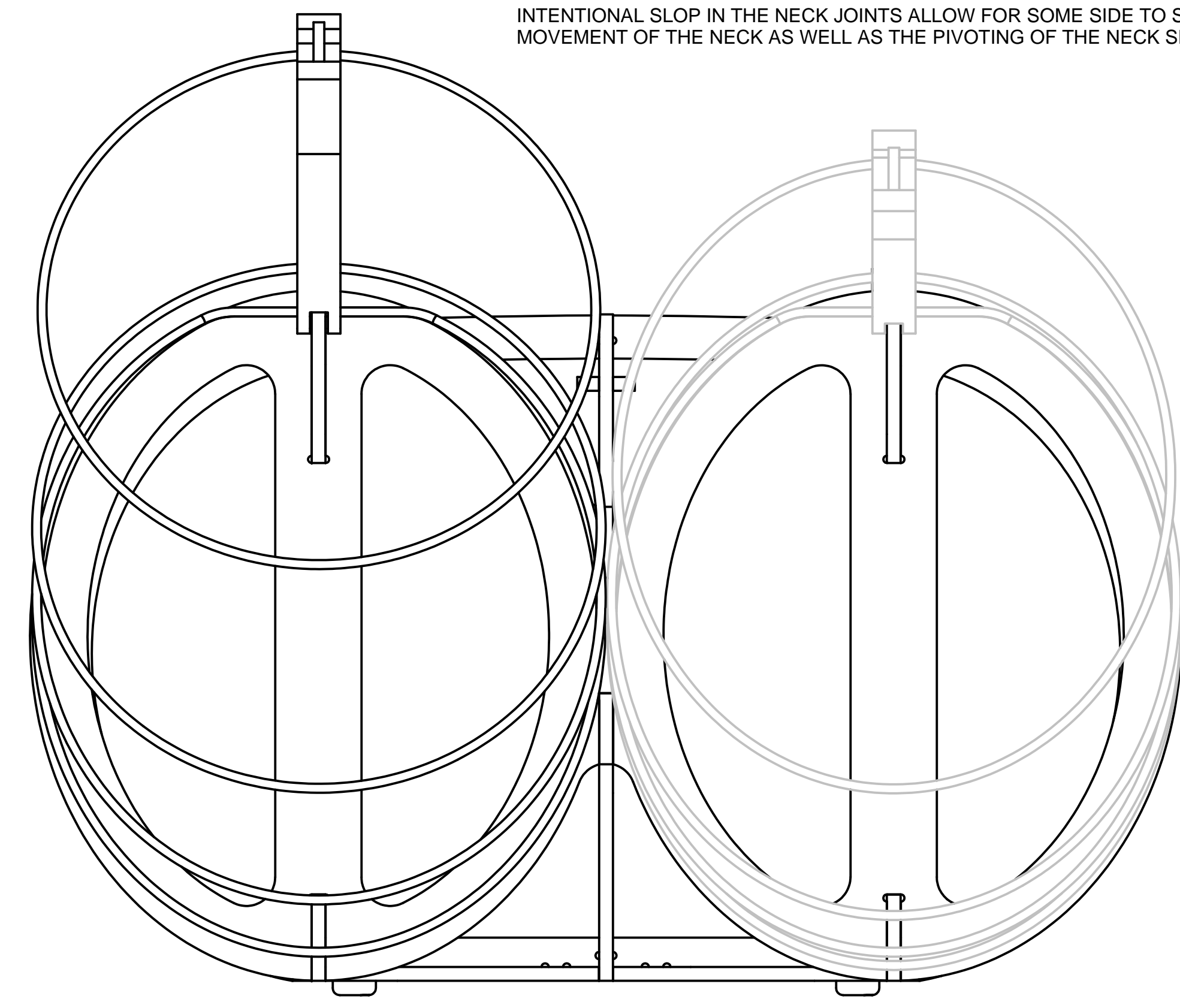

3 BODY-NECK JOINT - FACE
 3"=1'-0"

REFERENCED	
FROM	TO

JOB ID: _____
 DRAWN BY: **Ken Sly**
 APPROVED BY: _____
 ORIGINAL DATE: **2/1/2012**
 DUE DATE: _____
 SCALE: **3"=1'-0"**

SL2
 LATEST REVISION **A**

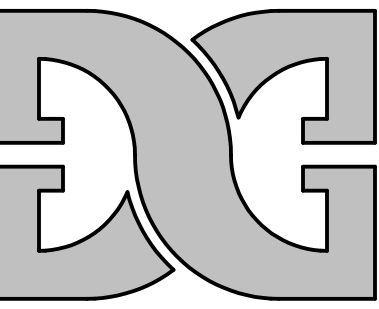

DIMENSIONAL GRAPHICS
 PHONE & FAX (650) 342-5724
 kenny@diglow.com
 www.diglow.com
 MATERIAL CALLOUTS ARE TO CLARIFY THE DESIGN INTENT. ALL DESIGN CONCEPTS AND MATERIALS MUST BE VERIFIED BY A LICENSED ENGINEER.

SNAKE HEAD/JAW ASSEMBLY
 SAN FRANCISCO OPERA
 MAGIC FLUTE 2012

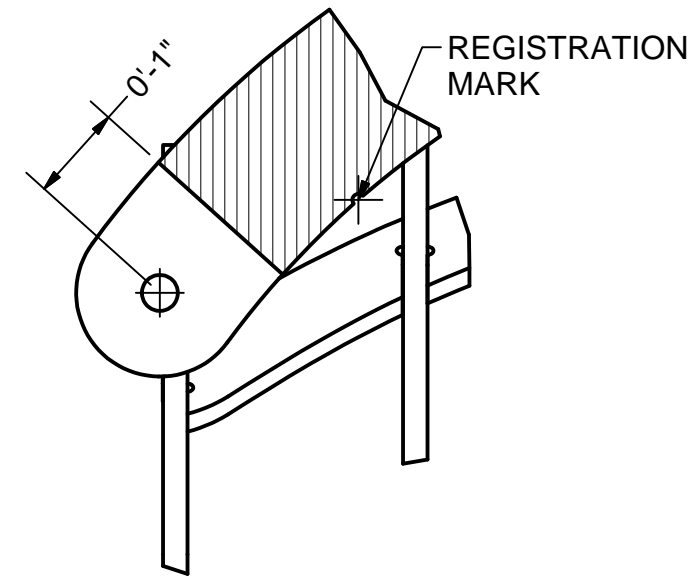

A SECTION
 HALF SIZE

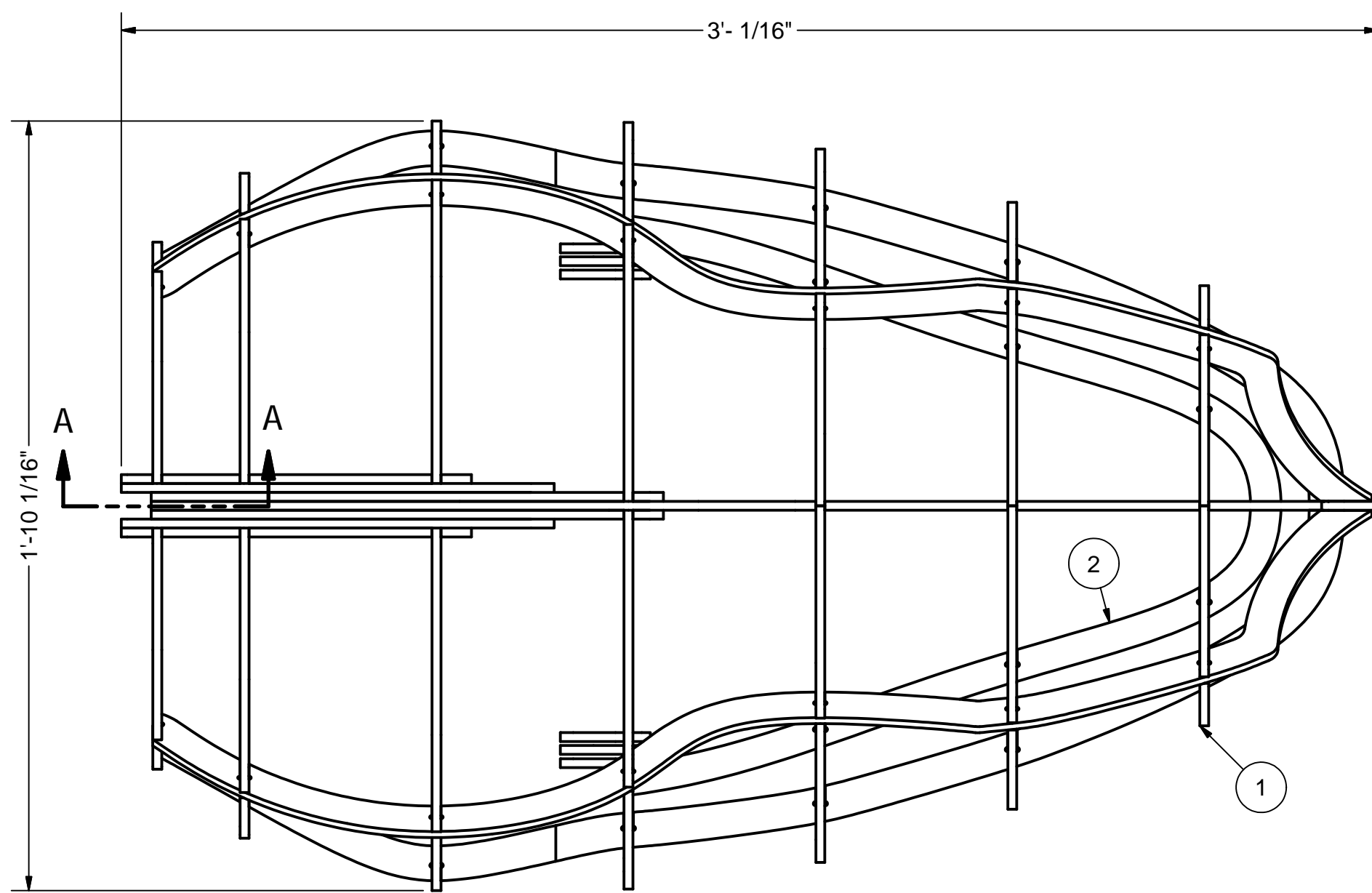

1 HEAD-JAW ASSM - PLAN
 3" \times 1'-0"
 2 REQUIRED

ALL PARTS ARE CUT FROM
 1/4" BIRCH PLYWOOD

2 ASSEMBLIES REQUIRED. MULTIPLY QUANTITY BY 2.

Parts List				
ITEM	QTY	PART NUMBER	DESCRIPTION	
1	1	Snake Head assm	SHEET SL4	
2	1	Snake Jaw assm	SHEET SL5	

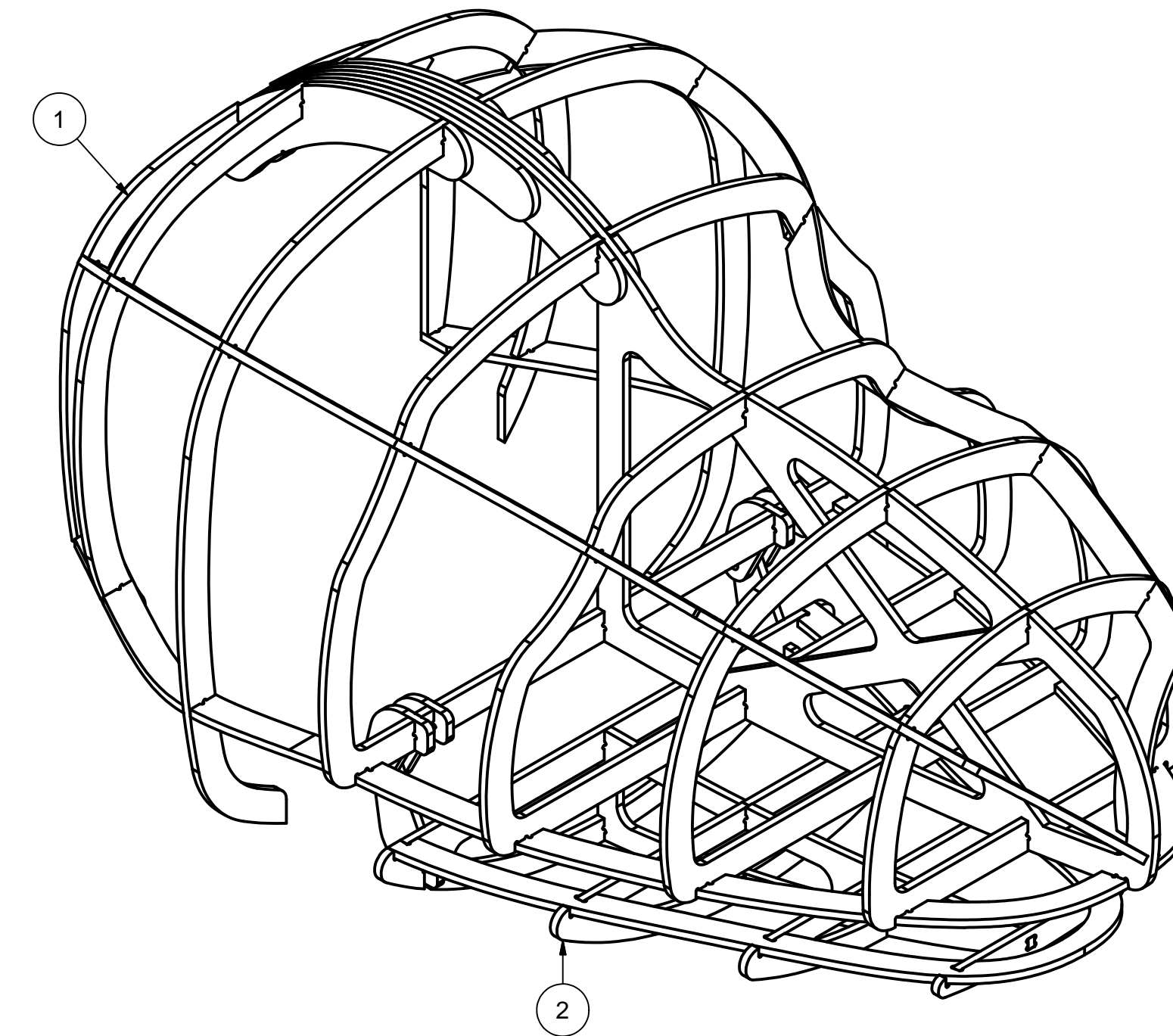

2 HEAD-JAW ASSM - ISO
 3" \times 1'-0"
 2 REQUIRED

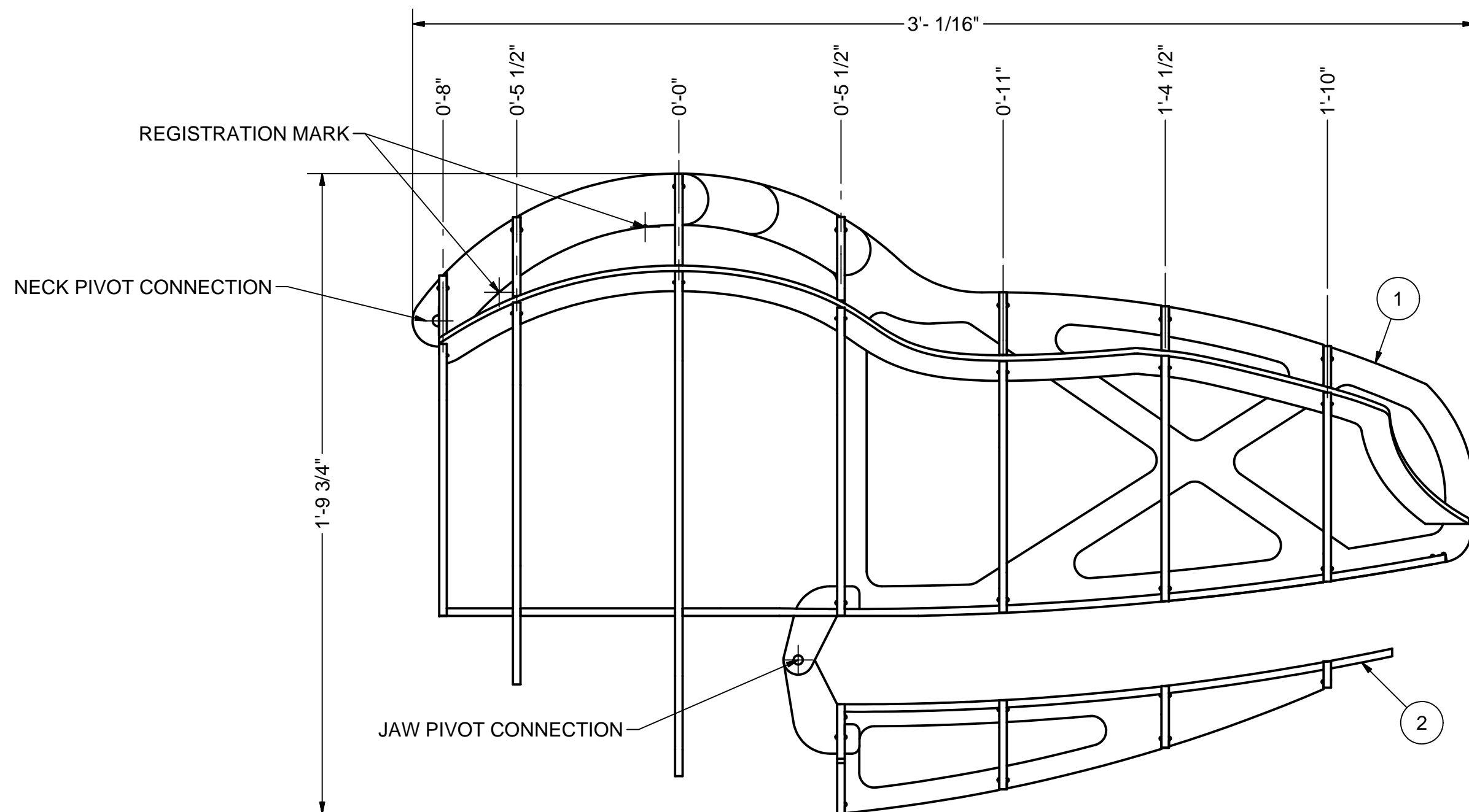

3 HEAD-JAW ASSM - SIDE
 3" \times 1'-0"
 2 REQUIRED

NOTES:
 JAW ANIMATION TBD.
 TEETH AND SKIN NOT SHOWN.

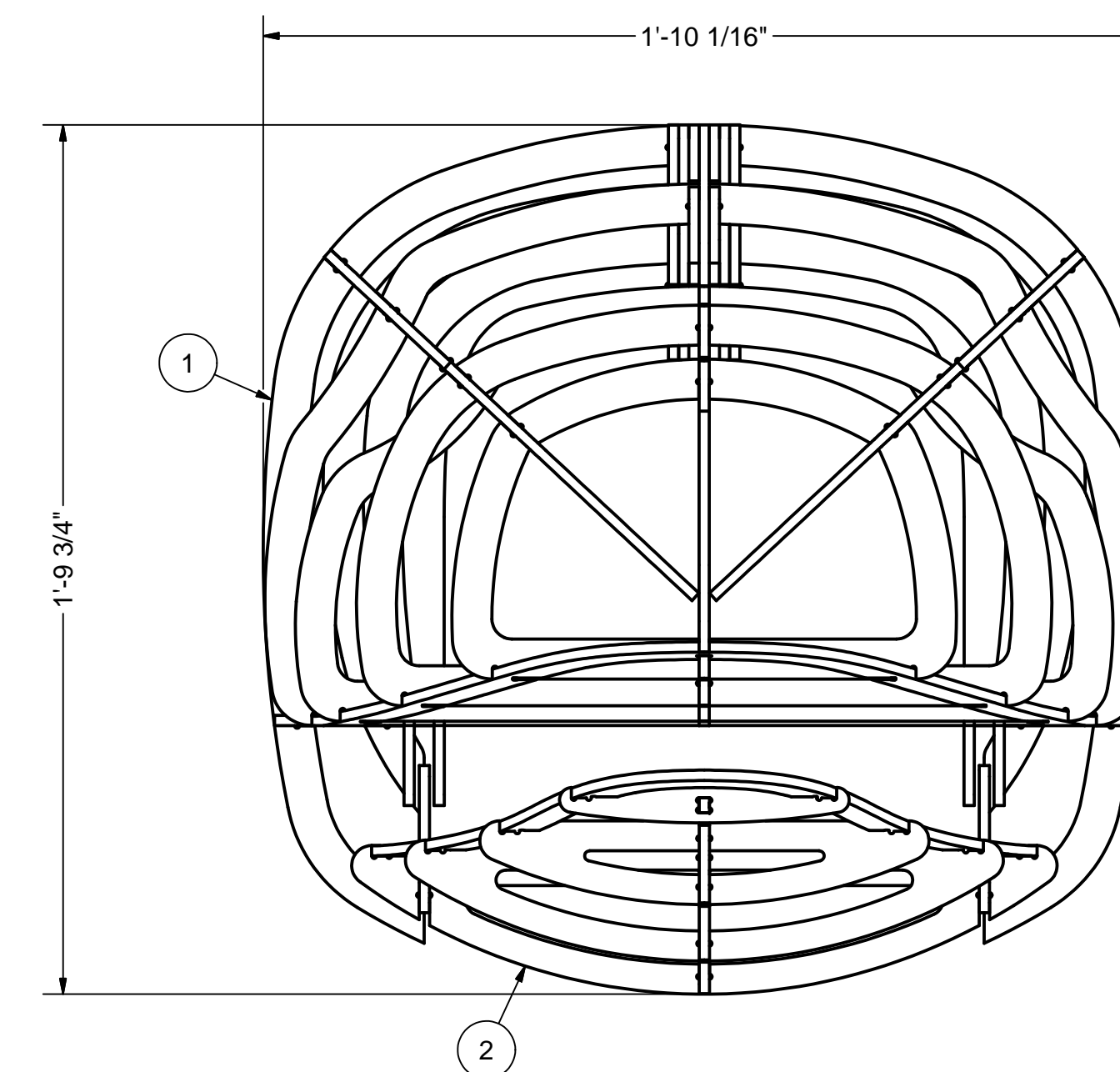

4 HEAD-JAW ASSM - FRONT
 3" \times 1'-0"
 2 REQUIRED

REFERENCED

FROM	TO

JOB ID: _____

DRAWN BY: Ken Sly

APPROVED BY: _____

ORIGINAL DATE: 2/13/2012

DUE DATE: _____

SCALE: AS NOTED

SL3

LATEST REVISION

A

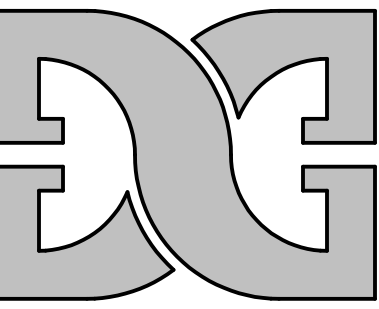

**DIMENSIONAL
GRAPHICS**

PHONE & FAX (650) 342-5724
kenly@dgflow.com
www.dgflow.com

MATERIAL CALLOUTS ARE TO CLARIFY THE
DESIGN INTENT. ALL DESIGN CONCEPTS AND
MATERIALS MUST BE VERIFIED BY A
LICENSED ENGINEER.

2 ASSEMBLIES REQUIRED. MULTIPLY QUANTITY BY 2.

Parts List			
ITEM	QTY	PART NUMBER	DESCRIPTION
1	1	Snake Jaw L1	SHEET SH4 VIEW 1
2	1	Snake Jaw R1	SHEET SH4 VIEW 3
3	2	Snake Jaw R2	SHEET SH4 VIEW 4
4	2	Snake Jaw R3	SHEET SH4 VIEW 5
5	1	Snake Jaw R4	SHEET SH4 VIEW 2
6	1	Snake Jaw lip bent	SHEET SH4 VIEW 7
7	2	Snake Jaw Hinge	SHEET SH4 VIEW 6

ASSEMBLY ORDER:
 1. ATTACH PARTS 2-5 TO PART 1.
 2. ATTACH PART 7 TO PART 5.
 3. ATTACH PART 6 TO THE ABOVE ASSEMBLY.

ALL PARTS ARE CUT FROM
1/4" BIRCH PLYWOOD

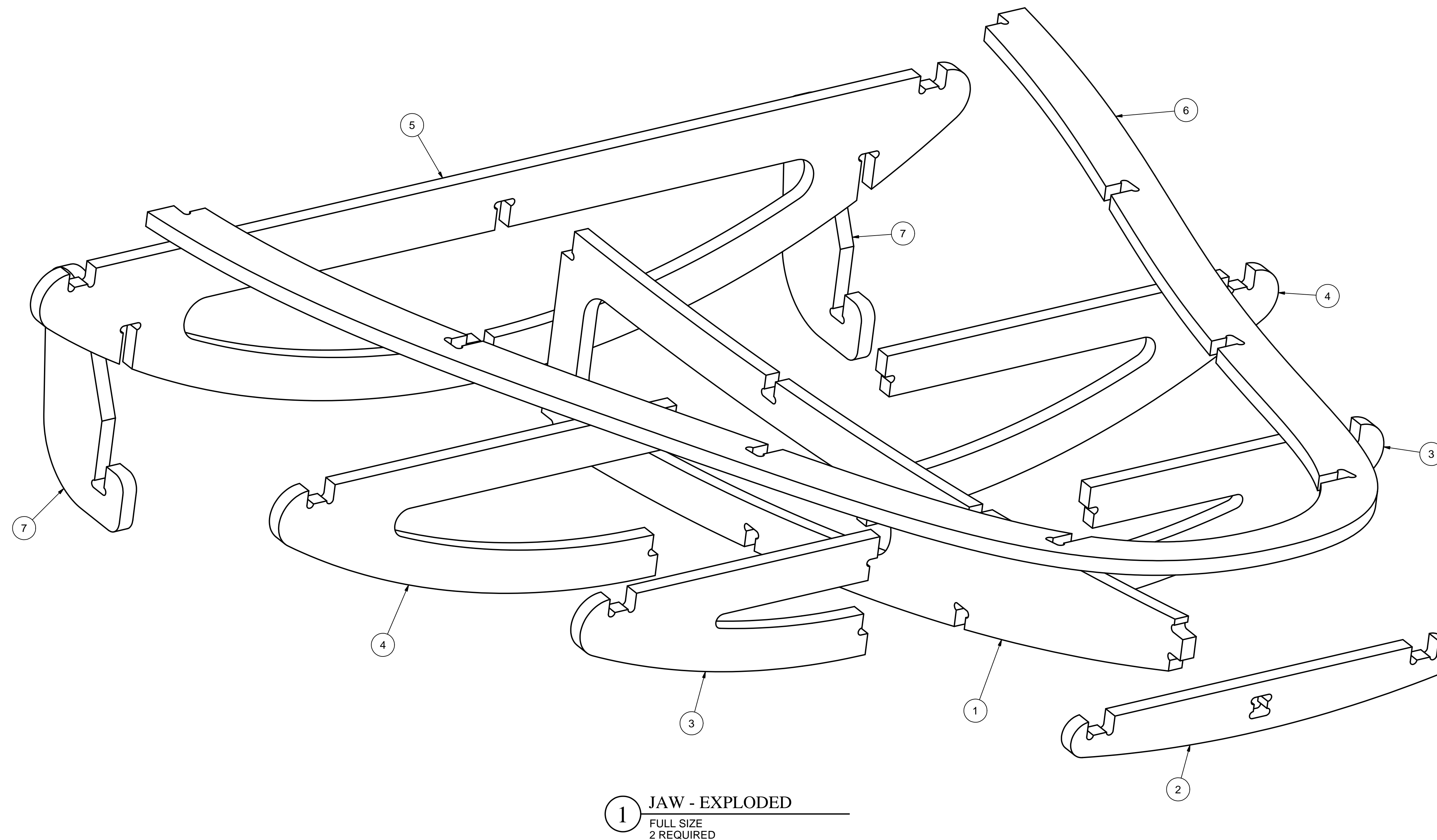

SNAKE JAW FRAME
 SAN FRANCISCO OPERA
 MAGIC FLUTE 2012

REFERENCED	
FROM	TO

JOB ID: _____
 DRAWN BY: Ken Sly
 APPROVED BY: _____
 ORIGINAL DATE: 2/13/2012
 DUE DATE: _____
 SCALE: FULL SIZE
SL5
LATEST REVISION

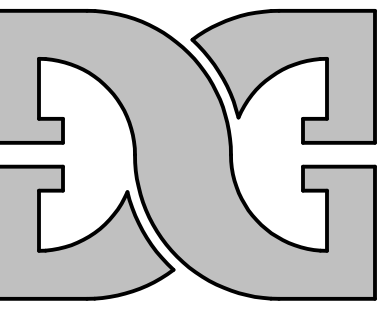

**DIMENSIONAL
GRAPHICS**

PHONE & FAX (650) 342-5724
ken@dgflow.com
www.dgflow.com
MATERIAL CALLOUTS ARE TO CLARIFY THE
DESIGN INTENT. ALL DESIGN CONCEPTS AND
MATERIALS MUST BE VERIFIED BY A
LICENSED ENGINEER.

SNAKE NECK LAYOUT
SAN FRANCISCO OPERA
MAGIC FLUTE 2012

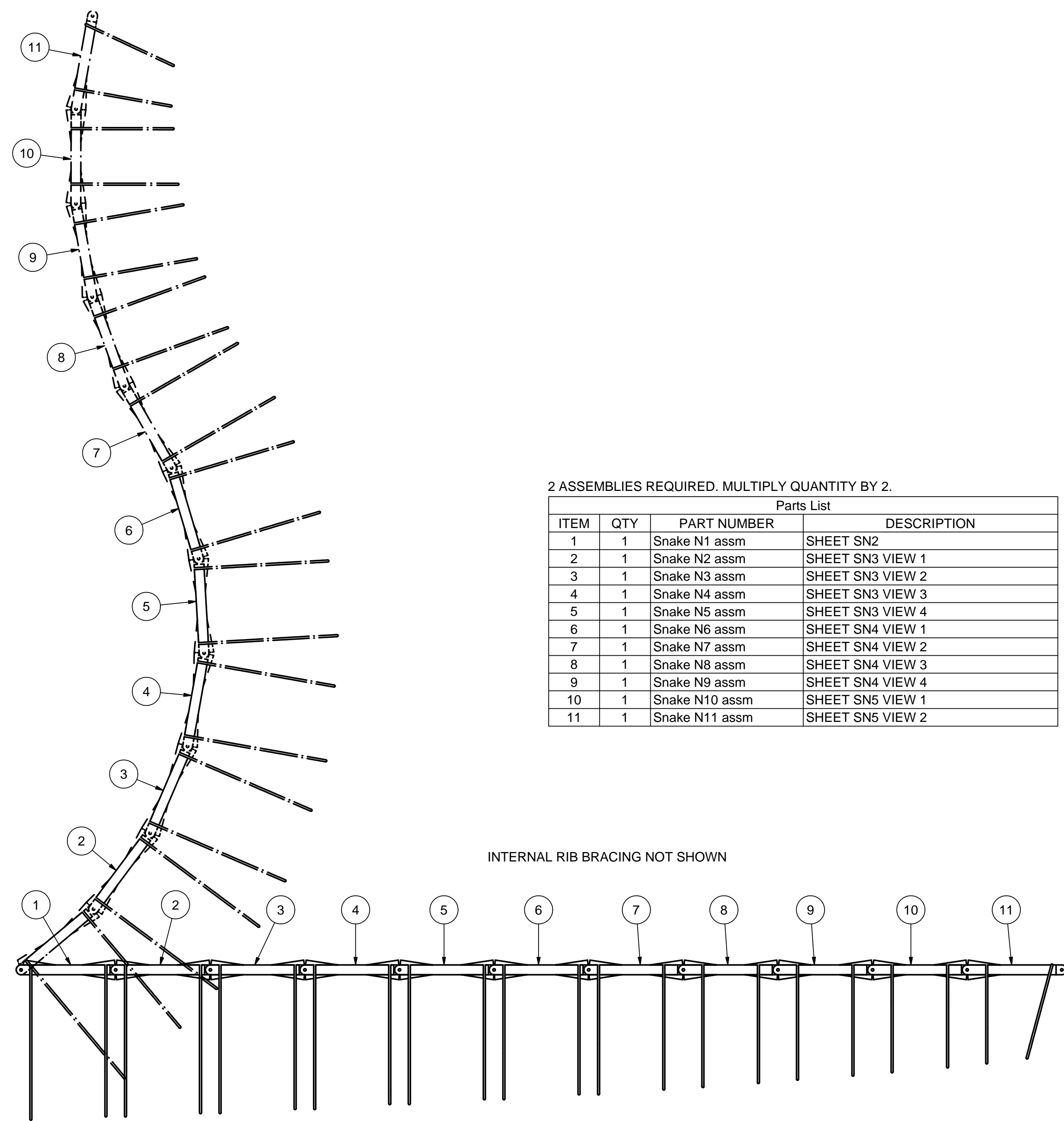

1 NECK ASSM - END VIEW
1"=1'-0"
2 ASSEMBLIES REQUIRED

2 NECK ASSM -SIDE VIEW
1"=1'-0"
2 ASSEMBLIES REQUIRED

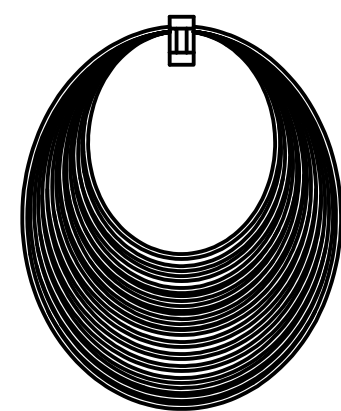

REFERENCED
FROM TO

JOB ID: _____

DRAWN BY: Ken Sly

APPROVED BY: _____

ORIGINAL DATE: 2/1/2012

DUE DATE: _____

SCALE: 1"=1'-0"

SN1

LATEST REVISION: 2/6/2012

B

2 ASSEMBLIES REQUIRED. MULTIPLE QUANTITY BY 2.

Parts List			
ITEM	QTY	PART NUMBER	DESCRIPTION
1	1	Snake N2	SHEET SP20 VIEWS 1-2
2	2	Snake N-stop 2	SHEET SP20 VIEWS 5-6
3	1	Snake N1Rb-N2Ra	SHEET SP13 VIEW 1
4	1	Snake N2Rb-N3Ra	SHEET SP14 VIEW 1
5	2	Snake N-stop 3	SHEET SP20 VIEWS 7-8

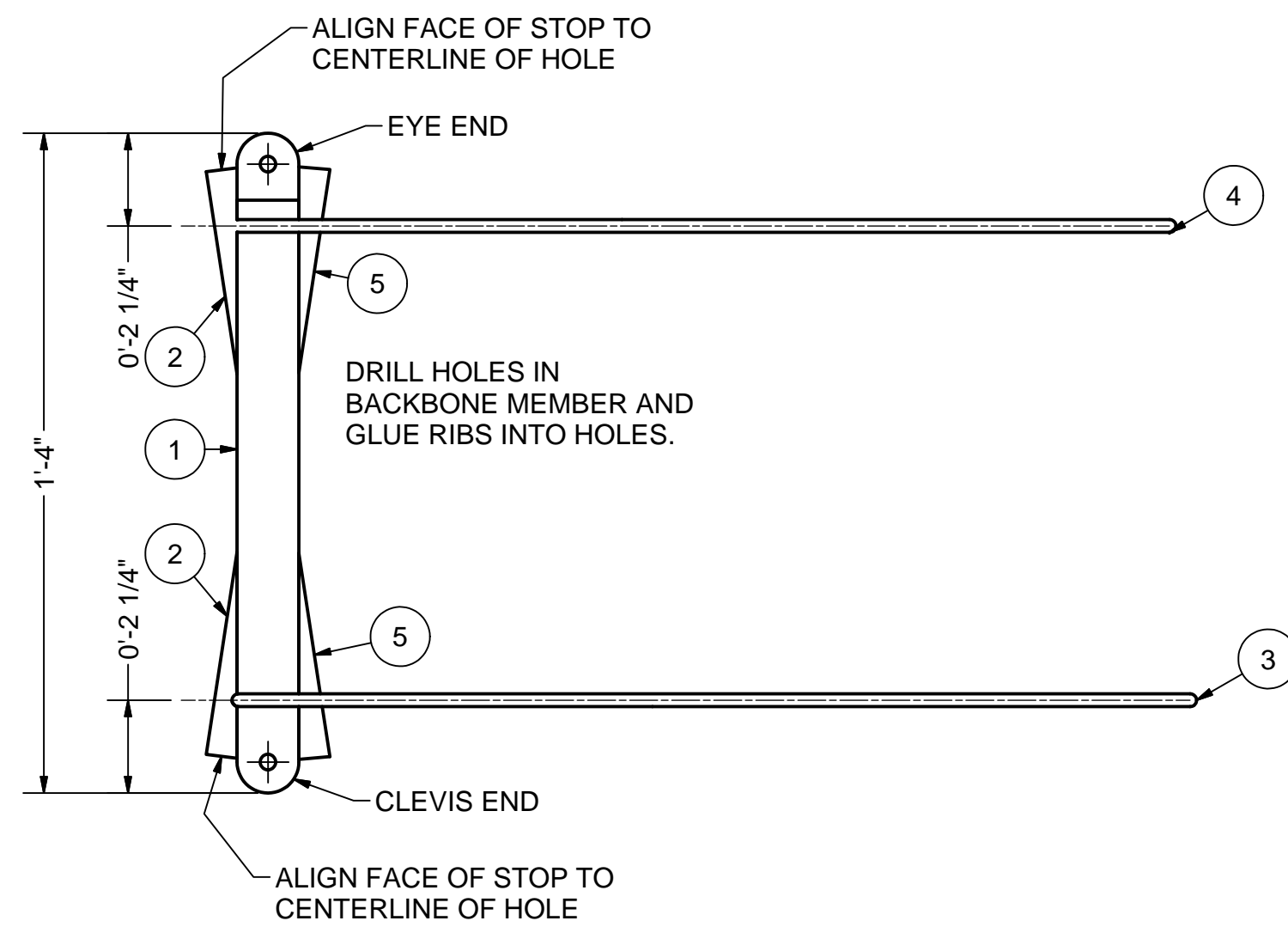

1 N2 ASSM - SIDE
3"=1'-0"
2 REQUIRED

NOTE:
REFER TO SHEET SN2 FOR
SIMILAR PROJECTED VIEWS
AND ADDITIONAL NOTES.

2 ASSEMBLIES REQUIRED. MULTIPLE QUANTITY BY 2.

Parts List			
ITEM	QTY	PART NUMBER	DESCRIPTION
6	1	Snake N3	SHEET SP20 VIEWS 1-2
7	2	Snake N-stop 2	SHEET SP20 VIEWS 5-6
8	1	Snake N2Rb-N3Ra	SHEET SP14 VIEW 1
9	1	Snake N3Rb-N4Ra	SHEET SP15 VIEW 1
10	2	Snake N-stop 3	SHEET SP20 VIEWS 7-8

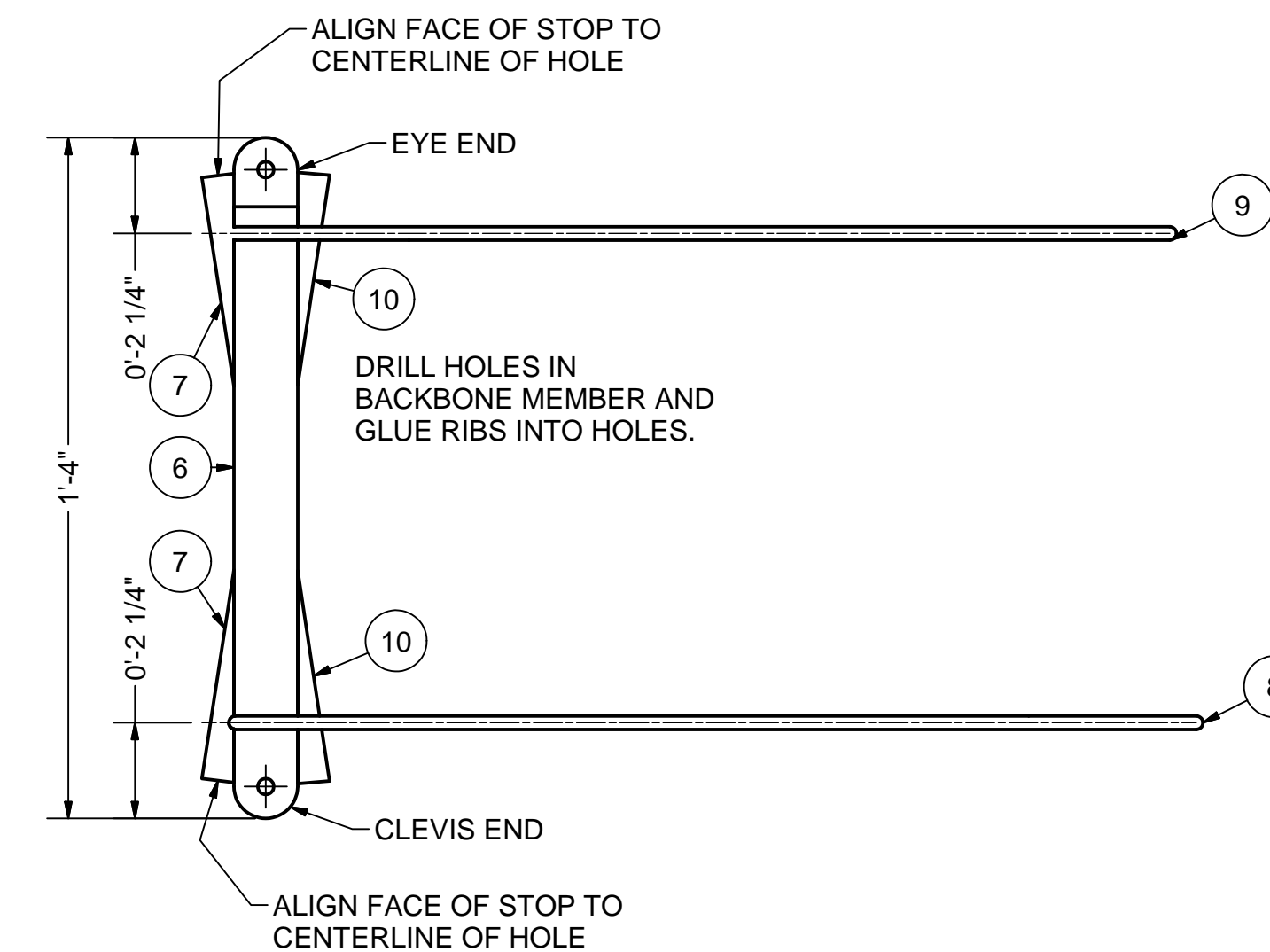

2 N3 ASSM - SIDE
3"=1'-0"
2 REQUIRED

2 ASSEMBLIES REQUIRED. MULTIPLE QUANTITY BY 2.

Parts List			
ITEM	QTY	PART NUMBER	DESCRIPTION
11	1	Snake N4	SHEET SP20 VIEWS 1-2
12	2	Snake N-stop 2	SHEET SP20 VIEWS 5-6
13	1	Snake N3Rb-N4Ra	SHEET SP15 VIEW 1
14	1	Snake N4Rb-N5Ra	SHEET SP16 VIEW 1
15	2	Snake N-stop 3	SHEET SP20 VIEWS 7-8

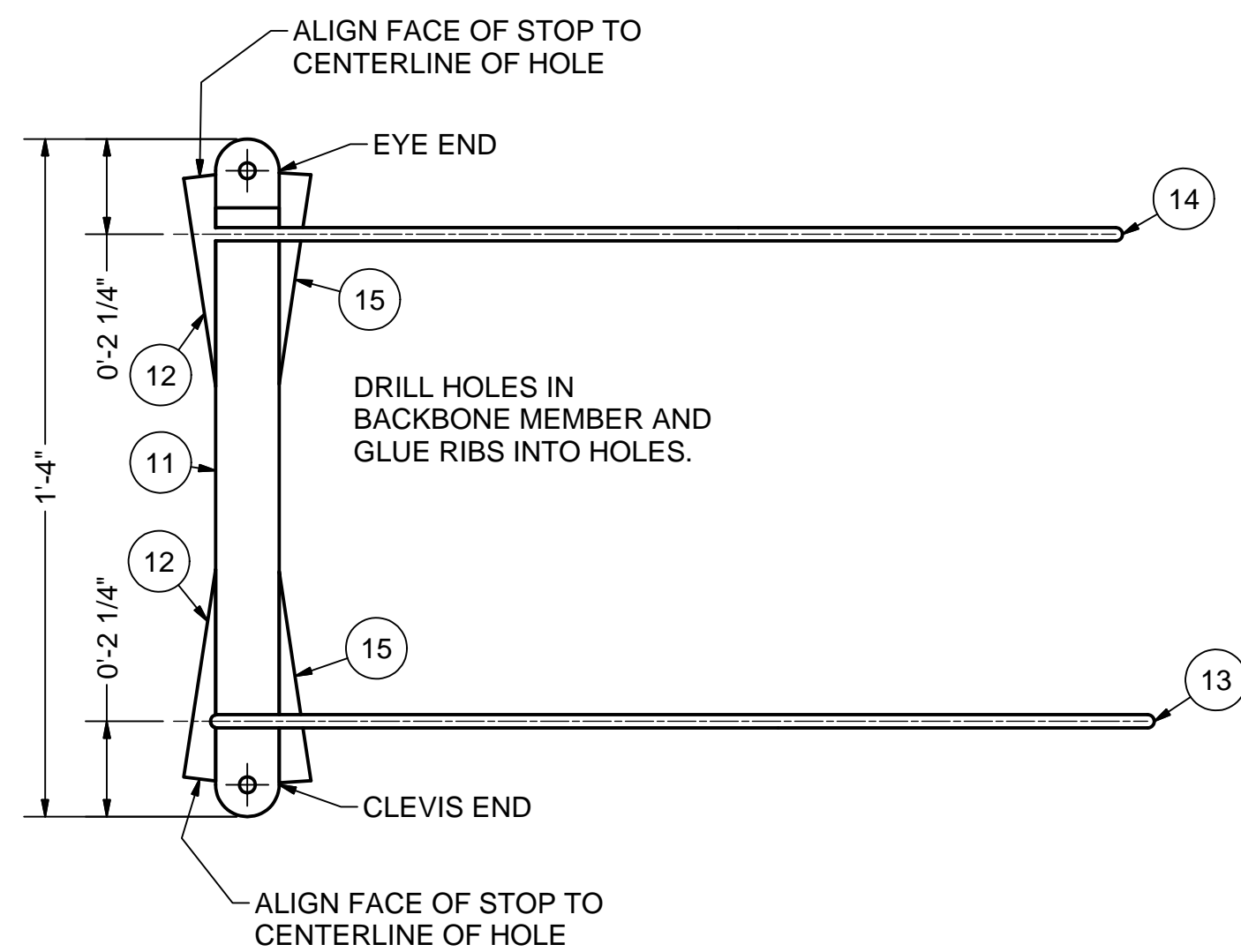

3 N4 ASSM - SIDE
3"=1'-0"
2 REQUIRED

2 ASSEMBLIES REQUIRED. MULTIPLE QUANTITY BY 2.

Parts List			
ITEM	QTY	PART NUMBER	DESCRIPTION
16	1	Snake N5	SHEET SP20 VIEWS 1-2
17	2	Snake N-stop 2	SHEET SP20 VIEWS 5-6
18	1	Snake N4Rb-N5Ra	SHEET SP16 VIEW 1
19	1	Snake N5Rb-N6Ra	SHEET SP17 VIEW 1
20	2	Snake N-stop 3	SHEET SP20 VIEWS 7-8

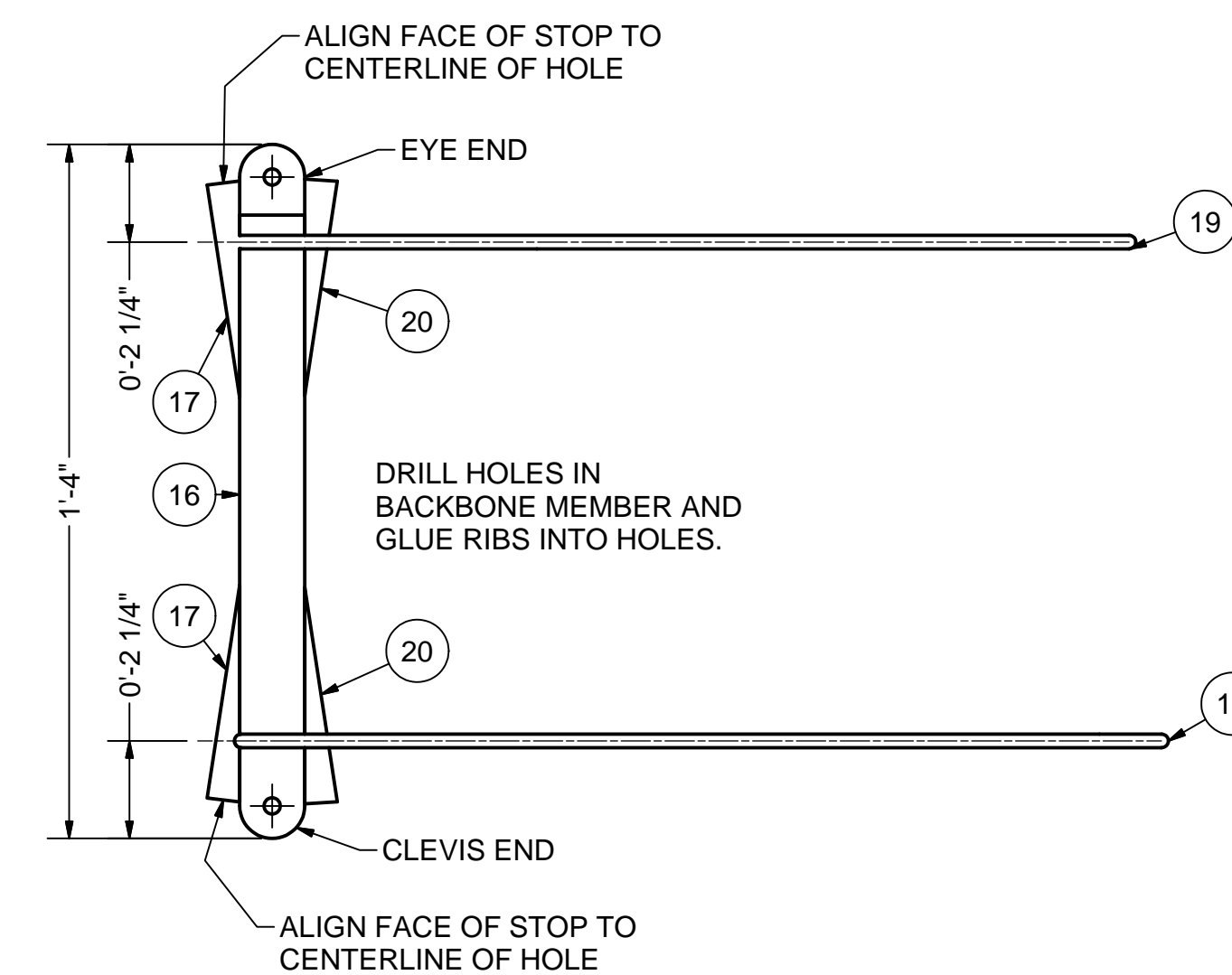

4 N5 ASSM - SIDE
3"=1'-0"
2 REQUIRED

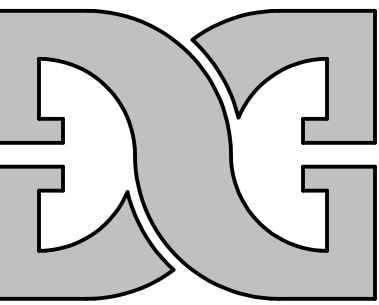

DIMENSIONAL GRAPHICS
PHONE & FAX (650) 342-8724
ken@dgflow.com
www.dgflow.com
MATERIAL CALLOUTS ARE TO CLARIFY THE DESIGN INTENT. ALL DESIGN CONCEPTS AND MATERIALS MUST BE VERIFIED BY A LICENSED ENGINEER.

SNAKE NECK FRAME LAYOUTS
SAN FRANCISCO OPERA
MAGIC FLUTE 2012

REFERENCED	
FROM	TO

JOB ID: _____
DRAWN BY: Ken Sly
APPROVED BY: _____
ORIGINAL DATE: 2/1/2012
DUE DATE: _____
SCALE: 3"=1'-0"

SN3
LATEST REVISION: 2/6/2012

2 ASSEMBLIES REQUIRED. MULTIPLE QUANTITY BY 2.

Parts List			
ITEM	QTY	PART NUMBER	DESCRIPTION
1	1	Snake N6	SHEET SP20 VIEWS 1-2
2	2	Snake N-stop 2	SHEET SP20 VIEWS 5-6
3	1	Snake N5Rb-N6Ra	SHEET SP17 VIEW 1
4	1	Snake N6Rb-N7Ra	SHEET SP18 VIEW 1
5	2	Snake N-stop 3	SHEET SP20 VIEWS 7-8

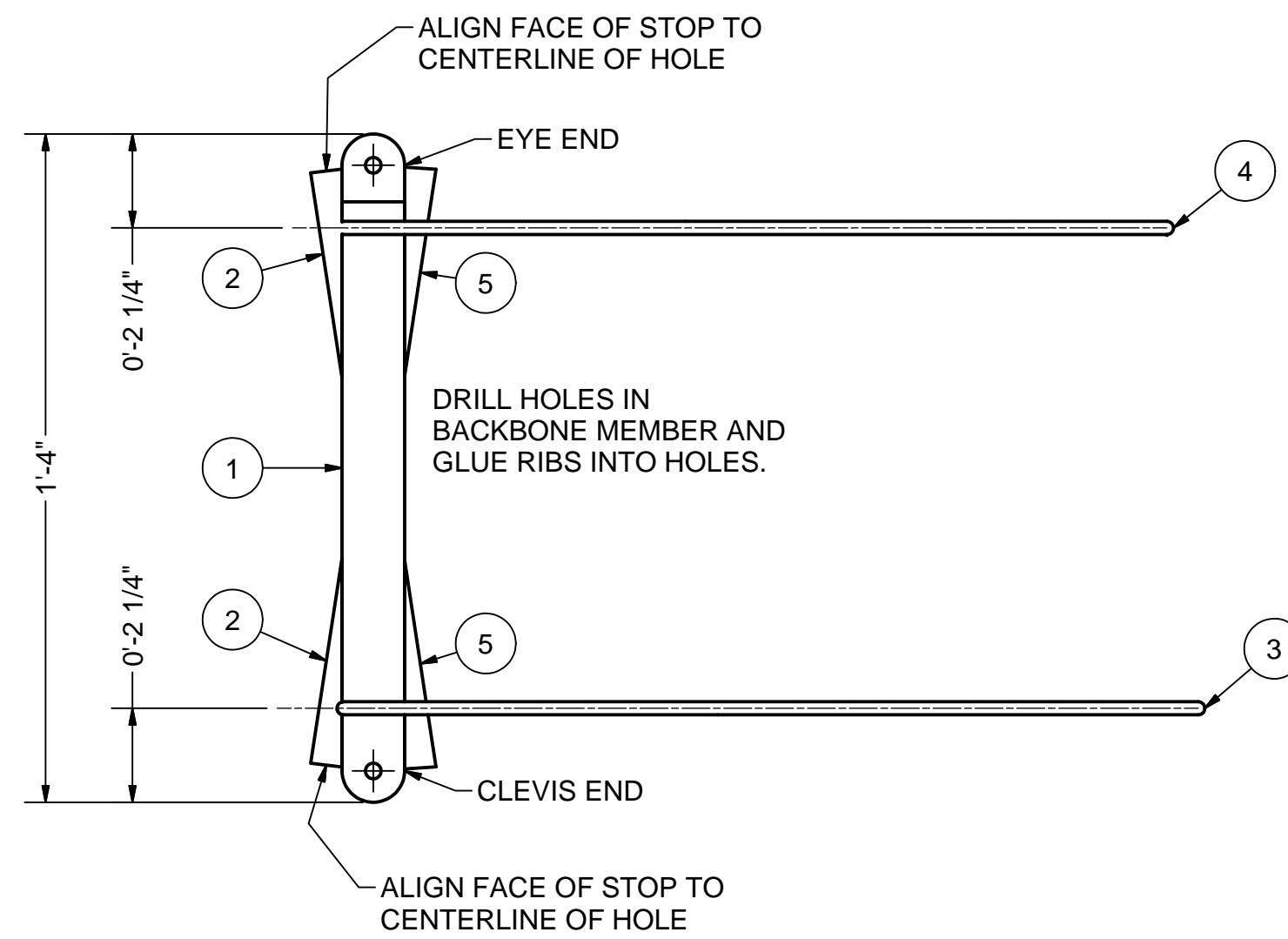

1 N6 ASSM - SIDE
3"=1'-0"
2 REQUIRED

2 ASSEMBLIES REQUIRED. MULTIPLE QUANTITY BY 2.

Parts List			
ITEM	QTY	PART NUMBER	DESCRIPTION
6	1	Snake N7	SHEET SP20 VIEWS 1-2
7	2	Snake N-stop 2	SHEET SP20 VIEWS 5-6
8	2	Snake N-stop 3	SHEET SP20 VIEWS 7-8
9	1	Snake N6Rb-N7Ra	SHEET SP18 VIEW 1
10	1	Snake N7Rb	SHEET SP11 VIEW 2

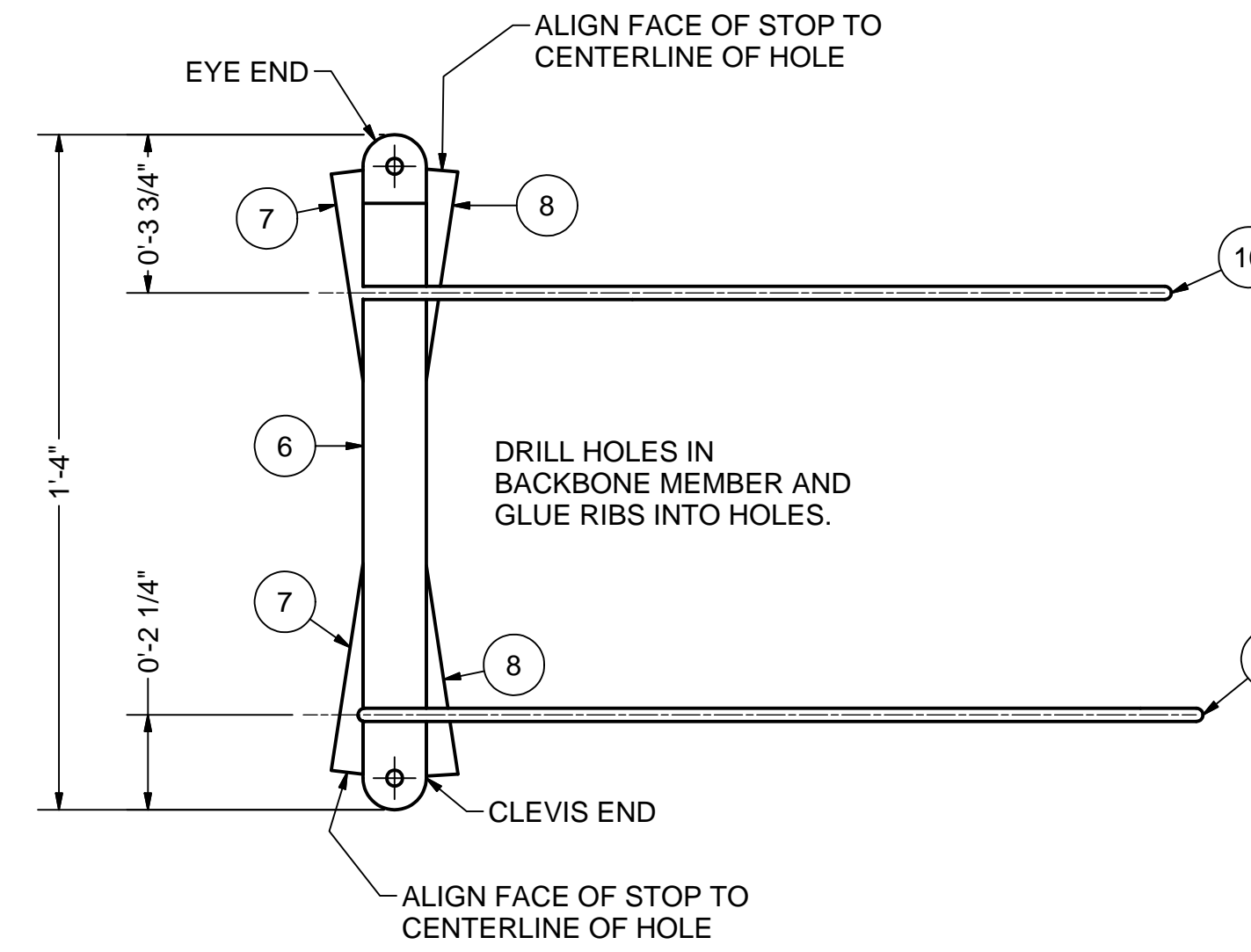

2 N7 ASSM - SIDE
3"=1'-0"
2 REQUIRED

NOTE:
REFER TO SHEET SN2 FOR
SIMILAR PROJECTED VIEWS
AND ADDITIONAL NOTES.

2 ASSEMBLIES REQUIRED. MULTIPLE QUANTITY BY 2.

Parts List			
ITEM	QTY	PART NUMBER	DESCRIPTION
11	1	Snake N8	SHEET SP20 VIEWS 1-2
12	2	Snake N-stop 3	SHEET SP20 VIEWS 7-8
13	1	Snake N8Ra	SHEET SP12 VIEW 2
14	1	Snake N8Rb	SHEET SP13 VIEW 2
15	2	Snake N-stop 2	SHEET SP20 VIEWS 5-6

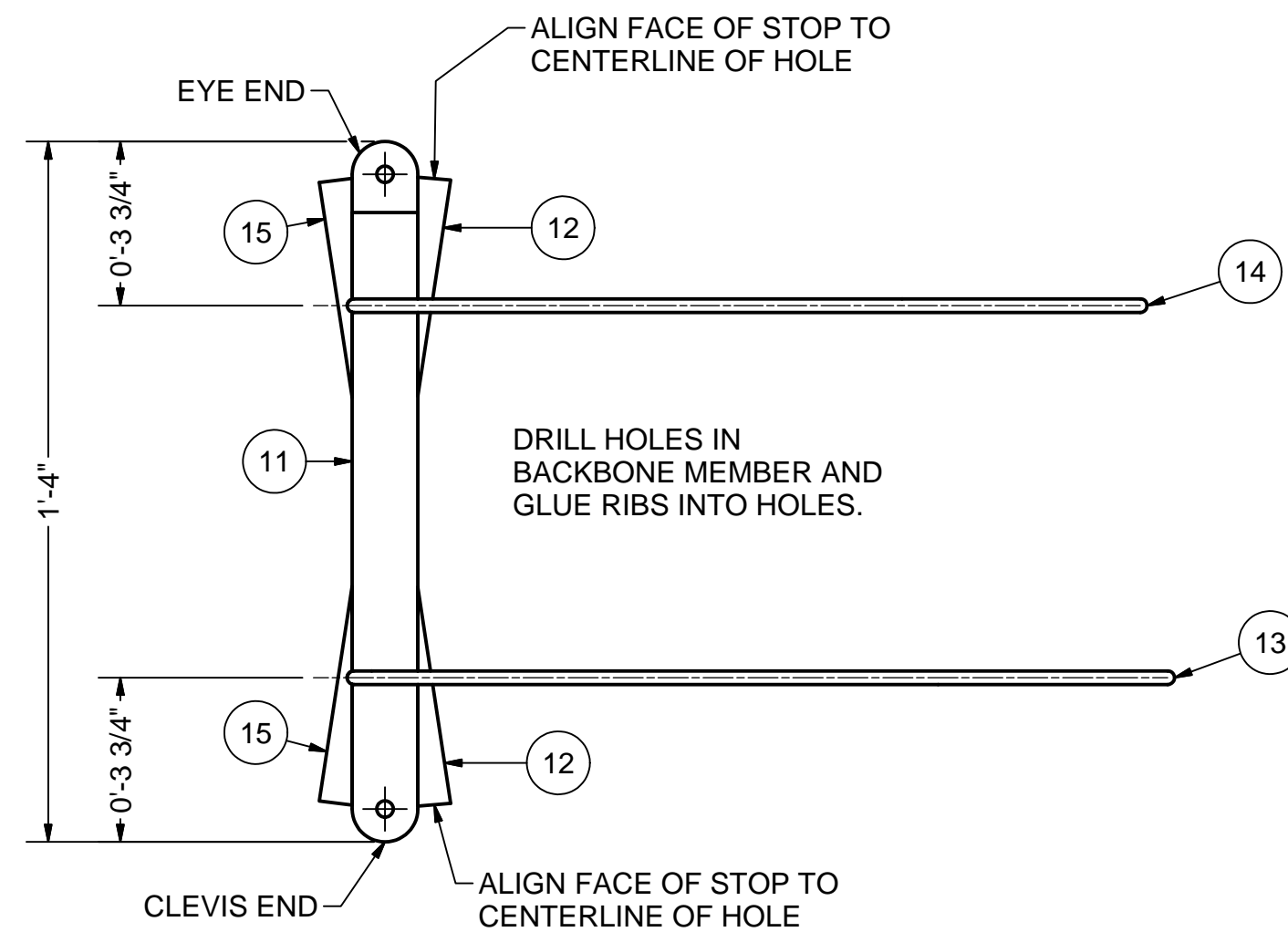

3 N8 ASSM - SIDE
3"=1'-0"
2 REQUIRED

2 ASSEMBLIES REQUIRED. MULTIPLE QUANTITY BY 2.

Parts List			
ITEM	QTY	PART NUMBER	DESCRIPTION
16	1	Snake N9	SHEET SP20 VIEWS 1-2
17	2	Snake N-stop 3	SHEET SP20 VIEWS 7-8
18	1	Snake N9Ra	SHEET SP14 VIEW 2
19	1	Snake N9Rb	SHEET SP15 VIEW 2
20	2	Snake N-stop 2	SHEET SP20 VIEWS 5-6

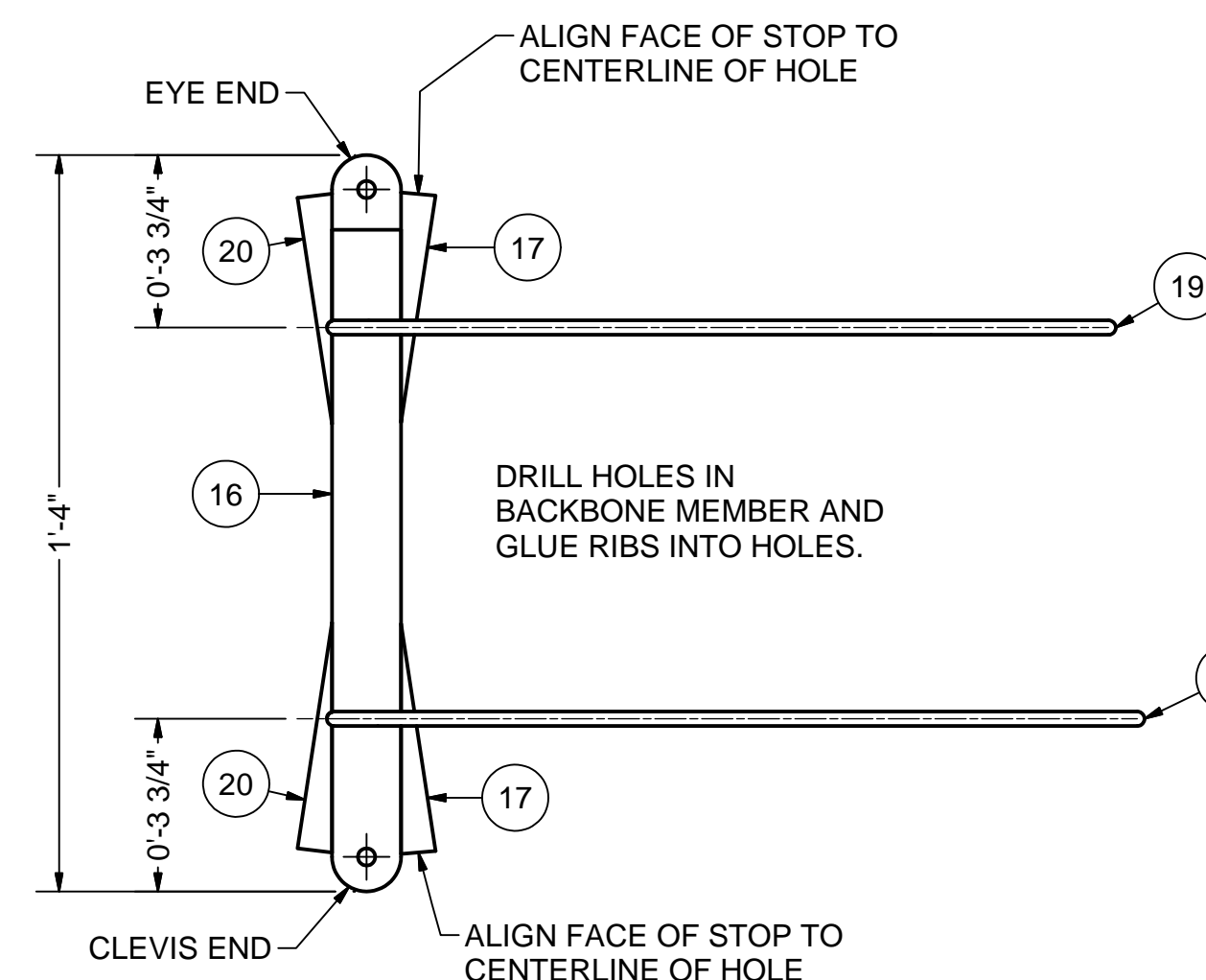

4 N9 ASSM - SIDE
3"=1'-0"
2 REQUIRED

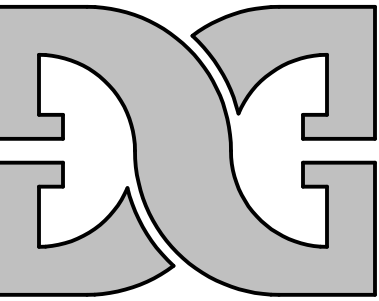

DIMENSIONAL GRAPHICS
PHONE & FAX (650) 342-5724
ken@dg.com
www.dg.com
MATERIAL CALLOUTS ARE TO CLARIFY THE DESIGN INTENT. ALL DESIGN CONCEPTS AND MATERIALS MUST BE VERIFIED BY A LICENSED ENGINEER.

SNAKE NECK FRAME LAYOUTS
SAN FRANCISCO OPERA
MAGIC FLUTE 2012

REFERENCED	
FROM	TO

JOB ID: _____
DRAWN BY: Ken Sly
APPROVED BY: _____
ORIGINAL DATE: 2/1/2012
DUE DATE: _____
SCALE: 3"=1'-0"
SN4
LATEST REVISION: 2/6/2012

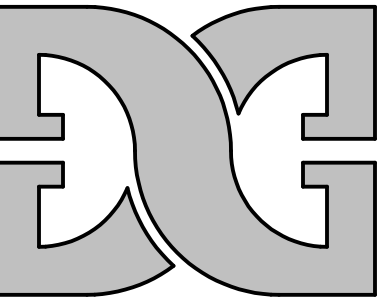

DIMENSIONAL GRAPHICS
 PHONE & FAX (650) 342-5724
 kenny@dimensionalgraphics.com
 www.dgflow.com
MATERIAL CALLOUTS ARE TO CLARIFY THE DESIGN INTENT. ALL DESIGN CONCERNS AND MATERIALS MUST BE VERIFIED BY A LICENSED ENGINEER.

2 ASSEMBLIES REQUIRED. MULTIPLE QUANTITY BY 2.

Parts List			
ITEM	QTY	PART NUMBER	DESCRIPTION
1	1	Snake N10	SHEET SP20 VIEWS 1-2
2	2	Snake N-stop 3	SHEET SP20 VIEWS 7-8
3	1	Snake N10Ra	SHEET SP16 VIEW 2
4	1	Snake N10Rb	SHEET SP17 VIEW 2
5	2	Snake N-stop 2	SHEET SP20 VIEWS 5-6

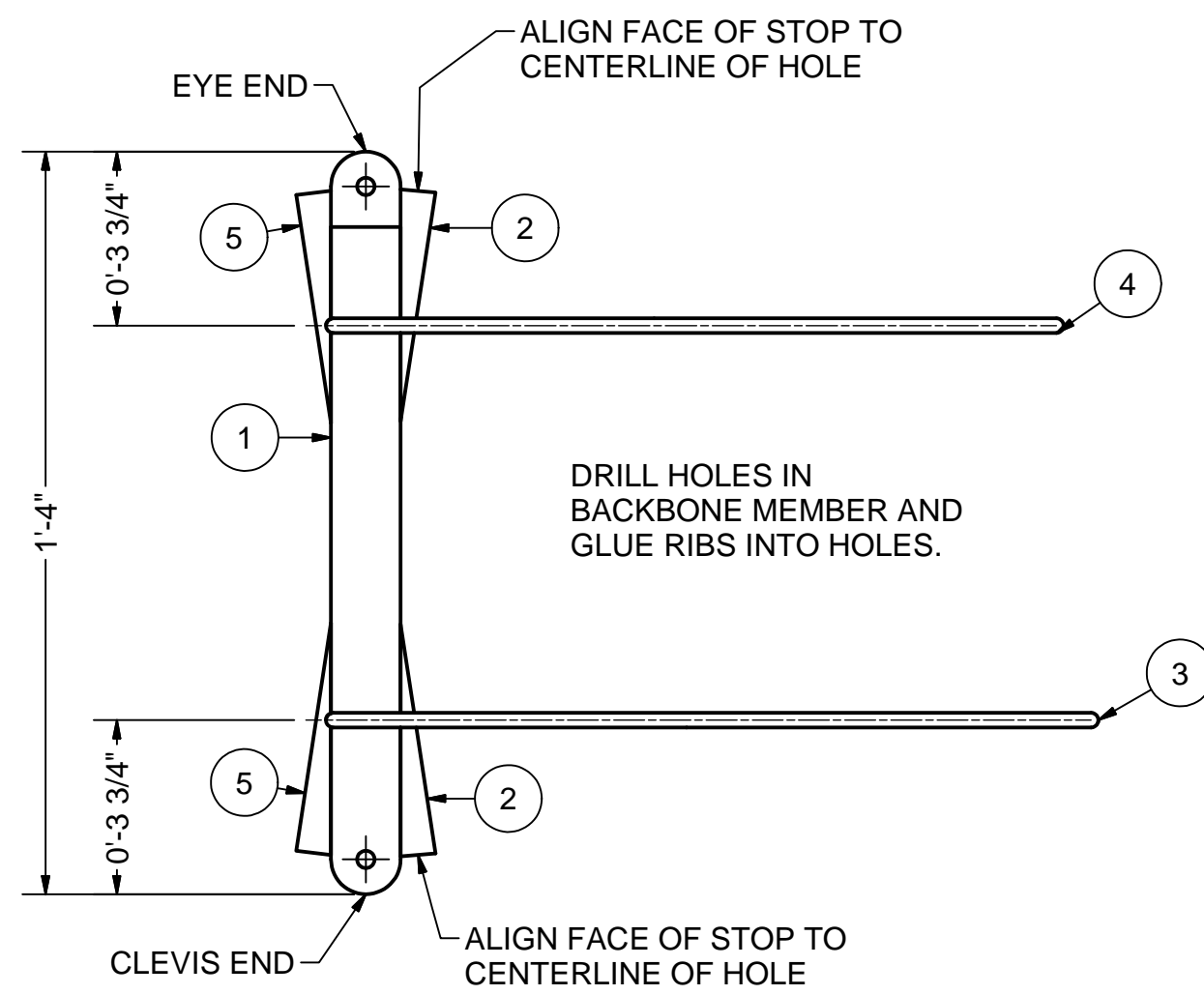

1 N10 - ASSM
 3"=1'-0"
 2 REQUIRED

NOTE:
 REFER TO SHEET SN2 FOR
 SIMILAR PROJECTED VIEWS
 AND ADDITIONAL NOTES.

2 ASSEMBLIES REQUIRED. MULTIPLE QUANTITY BY 2.

Parts List			
ITEM	QTY	PART NUMBER	DESCRIPTION
6	1	Snake N11	SHEET SP20 VIEWS 1-2
7	1	Snake N-stop 3	SHEET SP20 VIEWS 7-8
8	1	Snake N11Ra	SHEET SP18 VIEW 2
9	1	Snake N11Rb	SHEET SP19 VIEW 1
10	1	Snake N-stop 2	SHEET SP20 VIEWS 5-6

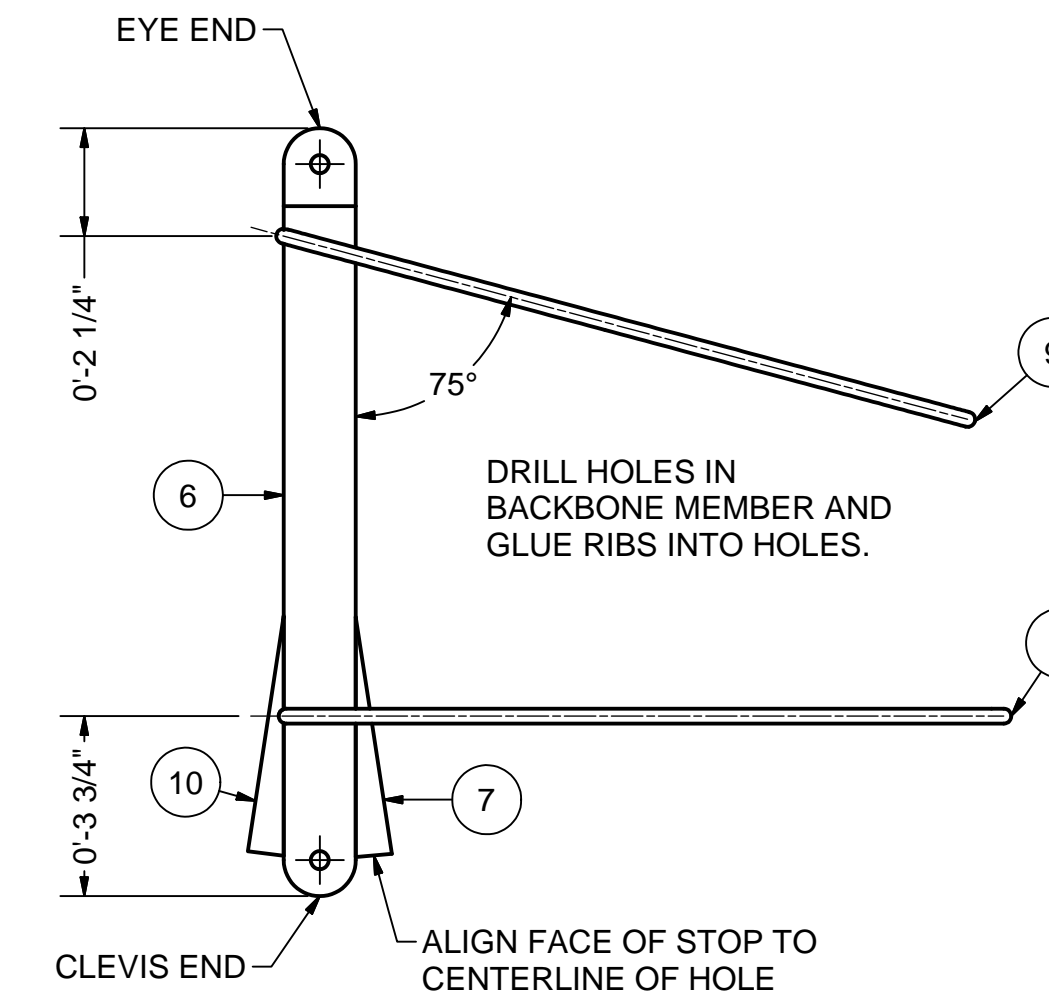

2 N11 - ASSM
 3"=1'-0"
 2 REQUIRED

**HOLD UNTIL HEAD IS
 DESIGNED**

SNAKE NECK FRAME LAYOUTS
 SAN FRANCISCO OPERA
 MAGIC FLUTE 2012

REFERENCED

FROM	TO

JOB ID: _____

DRAWN BY: Ken Sly

APPROVED BY: _____

ORIGINAL DATE: 2/1/2012

DUE DATE: _____

SCALE: 3"=1'-0"

SN5

LATEST REVISION: 2/6/2012

B