



Yale University Department of Music

Humperdinck and Wagner: Metric States, Symmetries, and Systems

Author(s): Daphne Leong

Source: *Journal of Music Theory*, Vol. 51, No. 2 (Fall, 2007), pp. 211-243

Published by: Duke University Press on behalf of the Yale University Department of Music

Stable URL: <https://www.jstor.org/stable/40283129>

Accessed: 26-02-2019 19:58 UTC

JSTOR is a not-for-profit service that helps scholars, researchers, and students discover, use, and build upon a wide range of content in a trusted digital archive. We use information technology and tools to increase productivity and facilitate new forms of scholarship. For more information about JSTOR, please contact support@jstor.org.

Your use of the JSTOR archive indicates your acceptance of the Terms & Conditions of Use, available at <https://about.jstor.org/terms>



JSTOR

Yale University Department of Music, Duke University Press are collaborating with JSTOR to digitize, preserve and extend access to *Journal of Music Theory*

Humperdinck and Wagner

Metric States, Symmetries, and Systems

Daphne Leong

Abstract Building upon recent geometric models of metric states by Richard Cohn and Scott Murphy, this article proposes a complementary model that expands the metric *states* that can be considered, relates states by *symmetries*, and creates *systems* of such states. Application of the model to Engelbert Humperdinck's *Hänsel und Gretel* and Richard Wagner's *Parsifal* reveals metric-dramatic strategies common to the two operas: certain metric symmetries parallel certain dramatic ones.

RECENT WORK BY Richard Cohn and Scott Murphy has modeled metric states and their relationships geometrically. Building upon and complementing these models, I introduce a new model that expands the metric *states* that can be considered, relates states by *symmetries*, and creates *systems* of such states. Application of this model to Engelbert Humperdinck's *Hänsel und Gretel* and Richard Wagner's *Parsifal* reveals metric-dramatic strategies common to the two operas.

The article begins with a brief exposition of Cohn's and Murphy's models. The limitations of these models motivate the development of the metric states, symmetries, and systems of my model, illustrated preliminarily in the scherzo of Beethoven's Ninth Symphony. Fuller application to *Hänsel und Gretel* and *Parsifal* demonstrates surprisingly sophisticated links between the two works. The article concludes by suggesting avenues for further exploration.

Cohn and Murphy

Both Cohn (2001) and Murphy (2006) base their models on the conception of meter as a hierarchy of pulse levels. Any such hierarchy is here called a *metric state*, following Cohn (2001, 296). Cohn and Murphy place specific restrictions on the metric states that they model; both writers deal only with states in which

Erin Lippard's 2005 paper provided the impetus for this study; I thank her for our subsequent discussions of the topic. I am grateful to Richard Cohn and Scott Murphy for their perceptive comments on an earlier version of this article, Yonatan Malin and Philip Chang for their helpful feedback on an oral version, and Elizabeth Medina-Gray for her useful critique. *JMT*'s anonymous readers also supplied many helpful comments.

Journal of Music Theory 51:2, Fall 2007

DOI 10.1215/00222909-2009-002 © 2009 by Yale University

211

pn RH	pn LH	violin	
A	B	C	
“12” 8	“6” 4	“3” 2	
○	○	○	
♪	♪ ← →	♪	
♪ ← →	♪	♪	
♪	(♪)	♪	

pn RH A

pn LH B

violin C

Example 1. Brahms, *Violin Sonata op. 78/1*, m. 235 (adapted from Cohn 2001, 304)

pulse levels are isochronous (consisting of evenly spaced pulses) and in which each pulse level relates to the next by a ratio of 2 or 3,¹ ensuring that each metric state is “fully consonant” as defined by Cohn (1992b, 8).

Example 1 shows a measure containing several metric states. The three “voices” of the example (piano right hand, piano left hand, violin), labeled A, B, and C, articulate the metric states diagrammed on the left of the example in columns. State A, for instance, consists of the pulse levels dotted-whole (the notated measure), dotted-half, dotted-quarter, and eighth note. The three states A, B, and C can be interpreted as 12/8, 6/4, and 3/2 meters, respectively.

Cohn’s (2001) ski-hill graphs (Figure 1a) arrange pulse levels related by ratios of 2 and 3 in two-dimensional lattices, where vertices on a lattice represent pulses, edges sloping downward to the right show triple divisions, and edges sloping downward to the left show duple ones. (Because we will be using these graphs frequently, the reader may find it useful to remember that edges sloping down toward the left foot are duple, those sloping down toward the right foot are triple: left foot duple, right foot triple $_2 \swarrow \searrow _3 _.$) In Figure 1a, paths on a ski-hill graph represent metric states; the three bold paths traced on the lattice of the figure and labeled A, B, and C represent the three metric states of Example 1. Path A, for example, moves downward to the left from dotted-whole to dotted-half to dotted-quarter note, showing duple relationships, and downward to the right from dotted-quarter to eighth note, showing a triple relationship.

Path B is the same as path A, except that where path A moves to the dotted-quarter note, path B moves to the quarter note. Similarly, paths B and C differ on only one level, that of B’s dotted-half note and C’s half note. Paths A and C, however, differ on exactly two levels: both begin and end with the same pulses (dotted-whole, eighth note) but differ in their intermediate levels. To represent such “distances” among paths, Cohn maps the paths of a ski-hill graph onto a metric space (Figure 1b), in which paths differing at exactly one

¹ Other pairs of prime integers are possible, such as 2 and 5, but Cohn and Murphy have chosen to work with 2 and 3.



Figure 1. Cohn's model: (a) ski-hill paths; (b) metric space

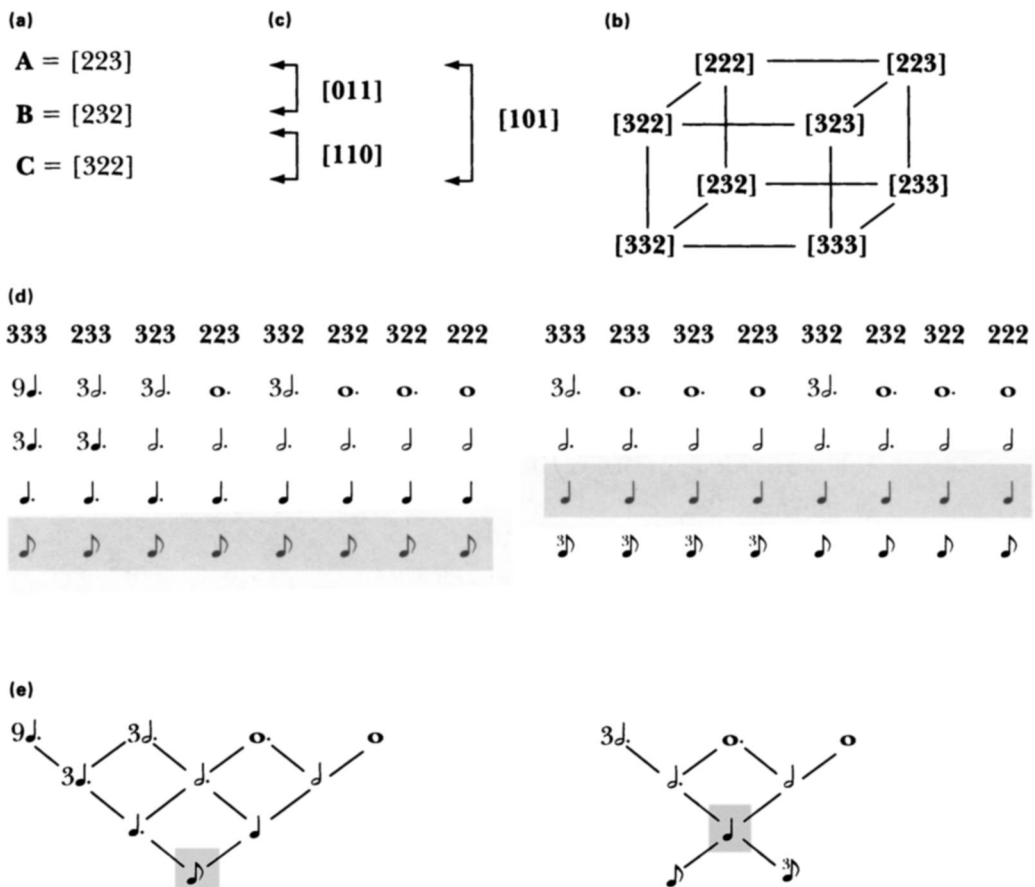

Figure 2. Murphy's model: (a) factor representations; (b) 3-cube; (c) toggling transformations; (d) two 3-cube realizations; (e) path representations of (d)

(corresponding) pulse level neighbor one another. A differs from B on one pulse level, and therefore neighbors it in Figure 1b; B similarly differs from C on one pulse level; A and C differ on two pulse levels and are therefore two “steps” apart in Figure 1b.

Murphy (2006) represents metric states primarily as lists of factors dividing pulses, ordered from slower pulse levels to faster ones. Our states A, B, and C, for instance, would be represented by Murphy as shown in Figure 2a. Compare Figure 1a’s path A with Figure 2a’s factor representation A: the factor representation [223] shows that the dotted-whole divides into 2 dotted-half notes, the dotted-half into 2 dotted-quarter notes, and the dotted-quarter into 3 eighth notes.² Murphy places metric states with n factors on an n -cube (Figure 2b), in which factor representations differing in exactly one corresponding place are adjacent.³ For instance, [222] is adjacent (connected by one edge) to [223], because they differ only in their last factor. [223] and [232] are separated by two edges since they differ in their middle and last factors. Murphy’s distance measurement and metaphorical space differ from Cohn’s: whereas Cohn’s paths A and B differ on one *pulse level* and are therefore one “step” apart in his metric space, Murphy’s factor representations A and B differ in two *factors* and are therefore two “steps” apart (separated by two edges) on Murphy’s cube.

Murphy models transformations between factor representations with “toggling” transformations (Figure 2c): ordered lists of 0s and 1s, where 1 changes a factor of 2 to a factor of 3 or vice versa, and where 0 maintains the existing factor. For instance, the transformation [011] changes factor representation A into factor representation B by maintaining the first factor and changing the second and the third factors.

Both Cohn and Murphy place specific restrictions on the constituents of their ski-hill graphs (and hence metric spaces) and n -cubes, respectively. Cohn, because of his focus on modeling hemiolic relations at various levels, requires all the paths on a ski-hill graph to begin at a single point, the “span pulse” at the top of the graph, and to end at a single point, the “unit pulse” at the bottom of the graph (which need not actually be present in a given musical passage).

Murphy requires all metric states on a given cube to share a common pulse on a corresponding level. The set of metric states on the 3-cube of Figure 2b is given two possible realizations in Figure 2d. The figure displays each metric state as a column. (Because the standard notational system has difficulty handling durations in multiples of 3, I have listed some of these simply as multiples of a smaller duration.) In the first set of realizations in Figure 2d, the eighth note is the pulse common to all of the metric states,

² Murphy borrows the factor representation from Cohn 1992a.

³ Justin London’s (2002b, 140–41) M-space is equivalent to a Murphy 6-cube in which the common pulse is the tactus (although London leaves out the “27/4” node needed to complete the symmetry). See also London 2004, 38–40.

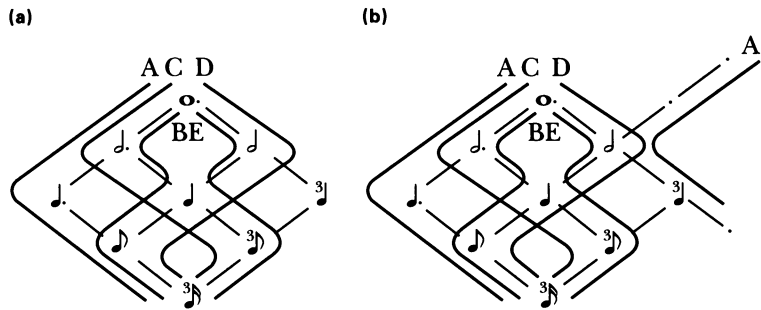

Figure 3. Ski-hill graph for Brahms, *Von ewiger Liebe* (adapted from Cohn 2001, 308–9): (a) Cohn; (b) with Ameling/Shetler's third-stanza path

on their bottom level; in the second set of realizations, the quarter note, on the second-from-the-bottom level, is the common pulse. These two sets of states are summarized graphically in Figure 2e (in which the states of Figure 2d form paths moving from the top level of each diagram down to the bottom level).

These restrictions on the constituents of Cohn's graph and hence his space, and on Murphy's cube, serve to circumscribe the metric states being modeled. But how, then, does one model metric states that do not fit within these constraints?

For instance, Cohn's (2001, 312–21) analysis of Brahms's *Von ewiger Liebe* produces the ski-hill graph shown in Figure 3a. The song's paths A, B, C, D, and E fit cleanly on this graph. However, most of the recorded performances that I surveyed⁴ produce a distinct version of path A at a slower tempo, in response to Brahms's new tempo indication *ziemlich langsam* at that point in the song. Figure 3b shows Elly Ameling and Norman Shetler's path A', of the same *shape* as path A, because it represents the same relations among pulse levels, but at a different *location* relative to the graph because of its distinct tempo.⁵

Cohn's and Murphy's graphs and cubes as they have defined them would have trouble addressing path A' in relation to the other paths of the song. Path A' does not have the same span and unit pulses as the song's other paths (Cohn), nor does it share a single pulse at the same level with all of the song's other paths (Murphy). To be able to address such paths, I develop a model complementary to those of Cohn and Murphy that focuses on path *shapes*.

⁴ The most representative of these were Ameling and Shetler 1995, Fassbaender and Gage 1982, Fischer-Dieskau and Engel 1995, Flagstad and McArthur n.d., and Norman and Parsons 1980.

⁵ Ameling and Shetler's 1995 performance begins at quarter note = 84; their path A' occurs at dotted-quarter note = 44, a tactus pulse approximately twice as slow as their opening

tactus, placing path A' where I have shown it in Figure 3b. (To follow Cohn's original path A, Ameling and Shetler would need to take a tempo of dotted-quarter note = 56, maintaining eighth-note equivalence with their opening tempo. Like many other performers, Ameling and Shetler accelerate to achieve this path A tempo near the end of the song.)

(a) 

(b) 

Example 2. Modeling dissonant metric states: (a) Humperdinck, *Hänsel und Gretel*, reh. 140+1; (b) diverging ski path. Engelbert Humperdinck, *Hänsel und Gretel* (vocal score by Horst Gurgel). © 1972 Edition Peters. Used by permission.

Metric states, symmetries, and systems

Like Cohn and Murphy, I deal with metric states in which pulse levels are isochronous and relate by ratios of 2 or 3, and, following Cohn, I represent such metric states as ski-hill paths. Unlike Cohn and Murphy, I do not require metric states under consideration to share a common pulse on a corresponding level, and because this loosening expands the terrain of Cohn's ski-hill graphs beyond their characteristic parallelogram shape, I will refer to my ski-hill paths simply as ski paths, and the lattices on which they are graphed simply as ski graphs, because they resemble cross-country ski terrain rather than defined ski hills with single tops and bottoms.

Furthermore, unlike Cohn and Murphy, I do not require my metric states to be consonant, that is, containing only pulse levels that relate by integer factors. Example 2a contains dissonant pulses—triplet-eighth notes and plain eighth notes, which do not relate by integer factors. It is useful to be able to model the metric structure of such passages as single (albeit dissonant) metric states. I therefore allow my metric states to include any state that can be created from the union of fully consonant states having (pairwise) at least one pulse level in common. The passage in Example 2a can then be represented as a single metric state, shown in Example 2b as a diverging ski path—so called because at the point of the quarter note, the descending skier has the choice

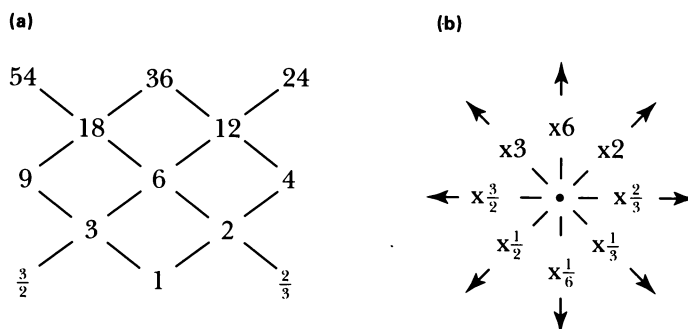

Figure 4. Ski-graph structure: (a) durations; (b) relationships

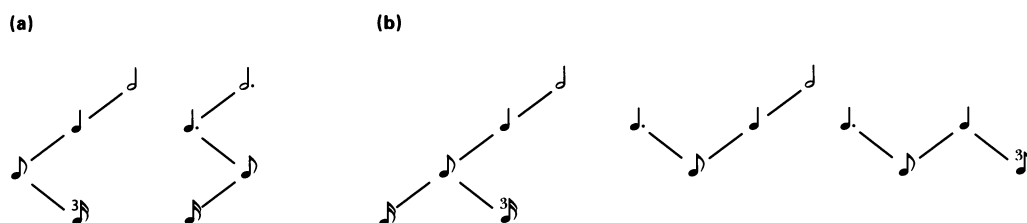

Figure 5. Consonant and dissonant ski paths: (a) consonant paths; (b) dissonant paths

of two diverging branches to follow (toward the eighth note or toward the triplet-eighth note).

A more explicit orientation to the ski graphs may be helpful at this point. Figure 4a presents a portion of such a graph, substituting rational numbers for pulse durations. Paths sloping downward to the right indicate triple divisions, and paths sloping downward to the left indicate duple ones. Longer pulse durations (slower pulse levels) occur higher in the graph, and shorter pulse durations (faster pulse levels) occur lower in the graph; moving leftward on the graph engenders longer pulse durations, and rightward, shorter ones. Figure 4b summarizes the relationships between a given pulse on the graph and the pulses surrounding it; the pulse directly above the origin pulse multiplies its duration by 6, the pulse directly to the right multiplies it by $2/3$, and so on.⁶ Pulses that occur on the same horizontal level of a graph do not relate by integer factors and are necessarily dissonant. Therefore, consonant ski paths cannot include more than one pulse at a given latitude: consonant paths (Figure 5a) must move consistently downward, without (Figure 5b) splitting into diverging branches or turning back upward.

I define relations among my metric states in terms of a subgroup of the group of symmetries of a square. As displayed in Figure 6, this subgroup consists of r_0 and r_{180} , rotations by 0° and 180° clockwise, and V and H, reflections across the vertical and horizontal axes. These symmetries relate ski-path representations of metric states; the middle column of the example shows their effect on a sample ski path. Rotation by 0° maintains the shape and orientation of the ski path. Rotation by 180° moves factors from low to high in the ski path and vice versa; a duple subdivision on the fastest, lowest level becomes a duple grouping on the slowest, highest level. Reflection across the vertical axis exchanges duple and triple factors on corresponding levels. Reflection across the horizontal axis swaps low and high while also swapping duple and triple; a duple subdivision on the lowest level becomes a triple grouping on

⁶ Many musical and cognitive factors belie the apparent symmetry of such a graph, including the greater prevalence of duple (rather than triple) hypermetric levels, perceptual

distinctions between lower and higher metric levels, and cognitive tempo thresholds for metric levels (London 2002a; 2004, 27–47).

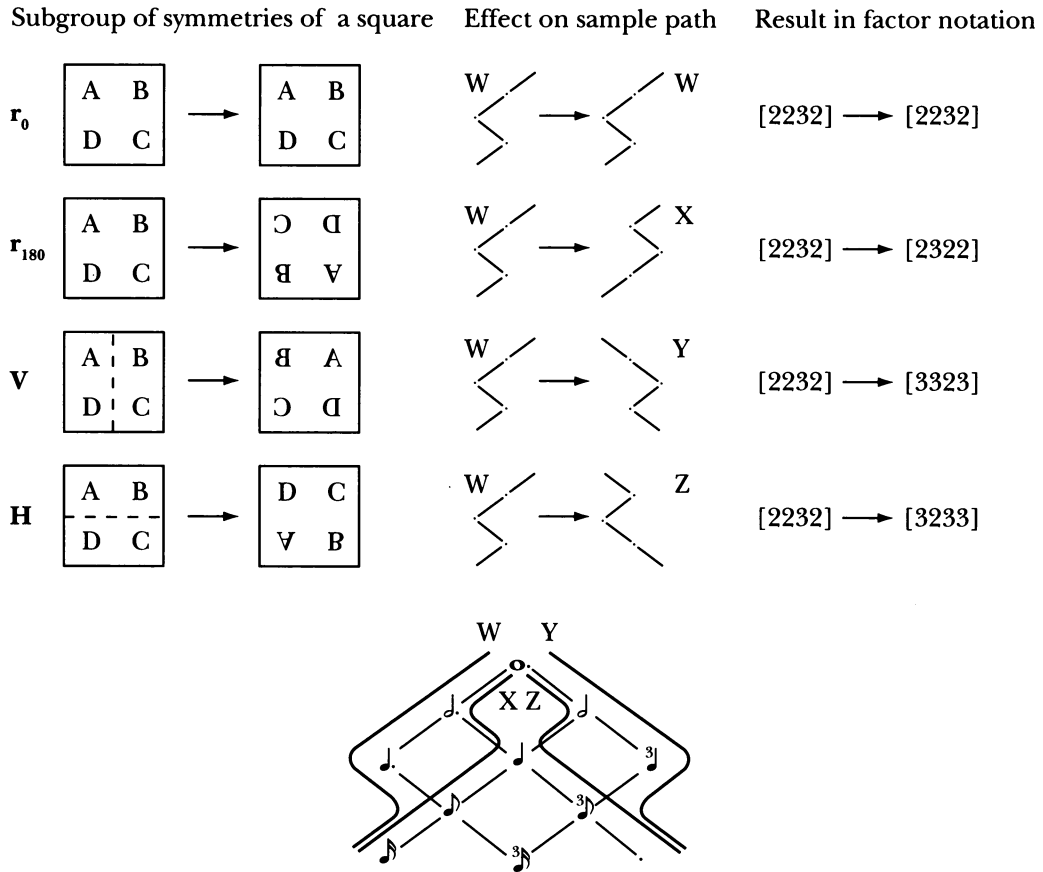

Figure 6. Metric symmetries

the highest level.⁷ The specific ski paths at the bottom of Figure 6 provide one realization of the symmetric relations shown above.

Example 3 displays two passages from the scherzo movement of Beethoven's Ninth Symphony. Example 3a shows the movement's first theme at the opening of the exposition; Example 3b shows the same theme when it reappears in *ritmo di tre battute* in the development. As shown by the ski paths to the left of these two passages, Example 3a articulates a quarter-note pulse,

⁷ The group of symmetries of a square also contains rotations by 90° and 270° clockwise, and reflections across the two diagonal axes. However, because these symmetries would turn common consonant metric states into unusually dissonant ones (turning paths that move consistently downward on a graph into paths that proceed sideways), I have opted to restrict my symmetries to the subgroup of Figure 6.

Incidentally, as shown by the factor representations on the right side of Figure 6, these four relations r_0 , r_{180} , V ,

and H affect factor representations in the same way that the canonical serial relations T , RI , I , and R affect ordered intervals. For example, T of some pitch-class segment X preserves $INT(X)$, the string of ordered intervals between the successive pitch classes of X ; r_0 of some ski path Y preserves $FR(Y)$, the factor representation of Y . In short form, $INT(T(X)) = INT(X)$, $FR(r_0(Y)) = FR(Y)$; $INT(RI(X)) = R(INT(X))$, $FR(r_{180}(Y)) = R(FR(Y))$; $INT(I(X)) = I(INT(X))$, $FR(V(X)) = I(FR(X))$, where I of a factor exchanges 2 and 3; and $INT(R(X)) = RI(INT(X))$, $FR(H(Y)) = RI(FR(Y))$.

(a)

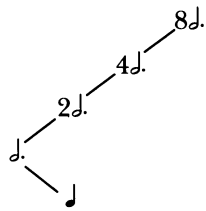

(b)

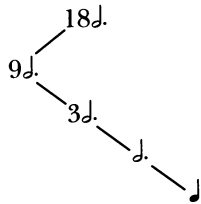

Example 3. Beethoven, Symphony no. 9, Scherzo: (a) theme 1, exposition; (b) theme 1, development

triply related to the dotted-half pulse of the measure level and moving upward in duple relationships to 2-, 4-, and 8-measure levels. The 4- and 8-measure levels are articulated by fugal entries alternating between D minor and A minor.⁸ Example 3b shows triple relations between the quarter note, dotted-half measure, and 3- and 9-measure levels, with a duple link to the 18-measure unit. These levels are expressed by imitative entries every 3 measures, harmonic changes every 9 measures, and a distinctive change in harmony, orchestration, and metric structure at the 18-measure point.

The two ski paths of Example 3 are H-related, mirroring one another across a horizontal axis. One might experience this symmetry as follows. Both paths contain a long diagonal stretch, connected at one end to a short jog in the perpendicular direction. In Example 3a, a listener might hear continuous duple factors connecting all levels from the dotted-half note up, in contrast to a qualitatively distinct triple factor connecting the quarter to the dotted-half note. In Example 3b, on the other hand, the listener could experience fluid triple links from the quarter note up to the 1-, 3-, and 9-measure levels, distinguished qualitatively from the duple 18-measure level.⁹

As already mentioned, I have defined my ski-path symmetries r_0 , r_{180} , V , and H as relations rather than operations.¹⁰ For operations, I would need to specify the point around which r_0 and r_{180} rotate, and the axis across which V and H reflect, so as to map a specific ski path (its shape and location) to another particular ski path. The subgroup of symmetries would need to include an additional class of operations T (translation) that would shift a path on its plane without altering its shape or orientation (each translation doing so by a specified distance and direction).¹¹ For instance, in Figure 7, path A maps to paths B, C, and D via various *operations*: to path B by reflection across the vertical axis that contains the quarter note, to path C by reflection across the vertical axis that contains the dotted-half note, and to path D by

⁸ My interpretation is based on parallel reading of the subject-answer entries. As Cohn (1992a, 198–99) has shown, the fugato can also be heard in 12- rather than 8-measure hypermeasures, based on the registral descent of the first three fugal entries followed by the regaining of the opening high register in the fourth entry. I prefer the 8-measure reading because it pairs entries in D minor and A minor and because it allows the arrival of V^7 later in the passage to fall on a hypermetric downbeat.

Cohn 1992a describes the movement in terms of hypermetric levels and the factors relating these levels, without taking the ubiquitous quarter note, the level below that of the measure, into consideration. (Here the distinction between meter and hypermeter, one of level, blurs even further because the notated measure, at *molto vivace*, serves as the felt tactus rather than as the felt metric unit.)

⁹ One can also attribute the distinct feel of the 18-measure duration to its length, which is likely to fall outside the general temporal threshold for perceiving

pulse groupings. (See note 24.) Nevertheless, the tight structure of the components within the 18-measure length, and its clear boundaries, will help the listener to hear it as a unit if not as a metric pulse per se.

This symmetry H , as well as the symmetry r_{180} , are harder to grasp intuitively than the symmetries V and r_0 , because H and r_{180} turn faster lower levels such as beat subdivisions into slower higher ones such as hypermetric beats (and vice versa). As just suggested, it may be easier to hear such symmetries in terms of shape relationships, rather than in terms of the specific pulses involved. One could also hear the mappings of specific pulses onto other pulses if other musical parameters, harmonic progression, for instance, connect the pulses concerned. (Thanks to Scott Murphy for the latter suggestion.)

¹⁰ I thank Scott Murphy for clarifying this distinction.

¹¹ The “ski-hill isographies” presented in Yonatan Malin 2003, 178–202, are translations eastward or westward.

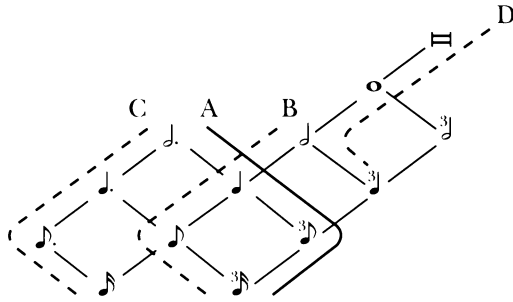

Figure 7. V: operations and relations

reflection across the quarter-note vertical axis followed by translation north-eastward by two units.¹²

More generally, path A relates to each of paths B, C, and D by the *relation* V. The relations r_0 , r_{180} , V, and H are equivalence classes. That is, let S be a member of our set of symmetries $\{r_0, r_{180}, V, H\}$ with a defined axis of rotation or reflection. Then, any operation that can be reduced to function composition of S and translation belongs to the equivalence class that contains S, that is, to one of the relations r_0 , r_{180} , V, or H. For now, I wish to exploit the generality of the relations r_0 , r_{180} , V, and H much as one might wish to focus on the canonical relations T, I, R, and RI, rather than on their constituent operations— T_7 , or RT_2I , for instance.

Even more generally, if one defines a ski-path *shape* as a ski path's particular configuration of left- and right-sloping edges, without reference to the particular pulses at the vertices of those edges, then the subgroup of symmetries as I have described them are operations on such shapes. This way of viewing the symmetries is more general than seeing them as relations on ski paths, because it allows one (via their shapes) to link ski paths that do not even occur on the same ski-graph plane, that is, whose tempi do not relate by factors of 2 or 3 (a distinct advantage when dealing with performed tempi).¹³ Each set of ski-path shapes related by the subgroup of symmetries so defined, together with the same subgroup under function composition, forms a system in the sense of David Lewin's (1987) Generalized Interval Systems.

To summarize, Cohn's and Murphy's criteria allow them to deal with limited sets of fully consonant metric states and to define finite metric spaces wherein these states can be located and the distances among them measured. The criteria also allow Murphy to define his toggling transformations as operations on metric states and not merely relations. Whereas Cohn and Murphy

¹² Other operations could also result in these mappings.

¹³ For instance, a 2/4 meter ski path at quarter note = 82 and a 2/4 meter ski path at quarter note = 97 could not occur on the same ski graph (since there are no integers m and n such that $82 \times 2^m \cdot 3^n = 97$), but these two path *shapes* map onto one another via the operation r_0 .

Even more generally, the symmetries as operations on *shapes* could link a shape on a ski graph made of factors of 2 and 3 with a shape on a ski graph made of other factors, say, 5 and 7. I do not define such ski graphs here.

focus on sets of metric states—their locations, distances, and transformational moves relative to one another—I highlight symmetric relations between metric states and allow these relations to play freely across all allowable dissonant or consonant metric states. Each of my metric systems, consisting of ski-path shapes related by the symmetry subgroup, can represent metric states in all possible tempi.

Hänsel und Gretel and Parsifal

I shall now apply this model to passages from Humperdinck's *Hänsel und Gretel* and Wagner's *Parsifal*. The two works exhibit quite clear associations between certain metric states and symmetries and particular dramatic contexts. Thus, while the metric structure shown by my states, symmetries, and systems can stand alone, my analysis of metric structure tends to find parallels in dramatic structure, allowing one parameter to interpret the other.

Hänsel und Gretel

Humperdinck's *Hänsel und Gretel* (1893) tells the story of two siblings who, lost in the woods, chance upon a magic gingerbread house. The sugary house lures children into the clutches of a wicked witch, who bakes her unwitting victims into gingerbread. Though tempted, Hansel and Gretel eventually realize their danger, outwit the witch, and push her into her own oven, causing the magic house to collapse and the gingerbread children to regain their human forms.

The development of my metric model was triggered by a paper by Erin Lippard (2005) that suggested that, in *Hänsel und Gretel*, simple meters associate with the dramatic depiction of reality, and compound meters with the portrayal of deception. I found that, more precisely, duple factors (not merely simple subdivisions) tend to accompany truth or reality, and triple factors (not merely compound subdivisions) deception or evil designs.

A few examples illustrate this association. When the witch presents herself as a sweet old lady who loves children (reh. 143), the meter reflects her falseness by changing from 6/8 to 9/8, featuring triple factors above and below the tactus. When later she exults in the heat of the oven (reh. 166-3),¹⁴ triple factors extend upward into hypermeter and downward into beat sub-subdivisions to illustrate the extent of her depravity.¹⁵ When, on the other hand, the gingerbread children regain their human forms (reh. 203-8), the multileveled meter is purely duple.¹⁶

¹⁴ I use \pm to indicate the number of measures before or after the rehearsal number.

¹⁵ Triple factors also accompany references to the supernatural, as when Hansel and Gretel discuss the angels in their dreams (reh. 120ff.) or when the children's father refers to God's help (reh. 211-2, reh. 211+6).

¹⁶ Hugh MacDonald finds that triple metric levels (primarily beat subdivisions and beat groupings) become associated in the late eighteenth and nineteenth centuries with pathos, death, the supernatural, expressive freedom, languor, and ecstasy. As these triple levels become increasingly common in nineteenth-century music (in French and Italian opera, for example), simple duple meters become associated with German music (MacDonald 1988, 231-37).

Our discussion focuses on act III, scene 3, which contains the main action at the gingerbread house. In this scene, 6/8 and 9/8 meter predominate, mixed with 2/4; Humperdinck maintains a constant tactus throughout the scene by equating the dotted-quarter note of compound time with the quarter note of simple time.

Example 4 presents a late stage in an alternation between 2/4 and 6/8 that begins, as shown in Example 5, when Hansel and Gretel first approach the gingerbread house. As they break a bit off the corner of the house, the witch's voice (Example 5a) issues forth in a 2/4 warning of reality: "Nibble, nibble, who is nibbling on my house?" The children, after a moment of uncertainty, taste the house (Example 5b) and express their delight, succumbing to deception in 6/8 meter. As they become increasingly engrossed in eating (Example 4), the 2/4 nibble theme incorporates triple factors, and the children's initial 2/4 in the example rapidly capitulates to 6/8.

The metric state of Example 4 is shown at the bottom right of the example. (I have represented it with a quarter-note tactus, though the passage uses quarter and dotted-quarter notes interchangeably.) The state features a prominent duple diagonal spanning eighth note to whole note, along with triple division into triplet-eighth notes. One might interpret this metric state thus: its dominant duple factors reflect the relative frankness of both witch and children at this point in the story, colored by the triple subdivisions of the children's delusion.

Example 6 shows a later passage in which the witch and the children try to deceive one another. In Example 6a, the witch, intending to push Gretel into the oven, asks her to check if the pastries are done. In Example 6b, Gretel, trying to foil the witch, stalls for time, and Hansel, sneaking out of his cage, whispers to her, "Sister dear, be very careful!" The metric state of these two passages, shown at the top of the example, displays a prominent triple diagonal, stretching from triplet sixteenths up to the 9/8 meter. Contradicted only by isolated duple sixteenth notes, this triple dominance could be interpreted as signaling the deceptive ruses of both parties.

Figure 8 reproduces the two metric states of Examples 4 and 6, the first state featuring a dominant duple diagonal, associated with frankness and transparency in the dramatic action, and the second state featuring a prominent triple diagonal, associated with deceptive ruses in the opera's story. The two states reflect one another across the vertical axis, and this metric relation parallels a dramatic one—the opposition of transparency and deception.

Example 7 provides another example of metric symmetries. After their initial meeting, the witch tries to entice Hansel and Gretel to remain at the house. The children are skeptical, and as they try to flee, the witch drops

Humperdinck used folk material from North Rhine-Westphalia as sources for *Hänsel und Gretel*; these sources, as reproduced in Irmen 1989, are prevalently duple in their metric structure: most feature simple duple

meter, several express compound duple meter, and one, the basis for the "Schwesterlein" music (Example 6b), is in simple triple meter.

140

GRETEL. *— 3 —*
 Wart, du nä-schi-ges Mäus-chen, gleich kommt die Katz' aus dem Häus-chen!

E. H. *p ausdrucksvoll*

Ob. *— 3 —*

HÄNSEL. (weiter kauend) *Knus-pre-nur zu* und laß mich in Ruh'!

GRETEL. (reißt ihm das Stück aus der Hand) *Nicht so ge-schwind, Herr*

Fl. *p cresc.*

Ob. *— 2 —*

allmählich beschleunigend

HÄNSEL. (nimmt es ihr wieder) *Himm-li-sches Kind, ich nehm', was ich find'!*

GRETEL. (lachend) *Ha ha ha ha ha*

Wind, Herr Wind!

Str. *p*

HEXE (grell lachend) *ha ha ha ha ha ha ha! Hi hi, hi hi, hi hi hi hi hi hi!*

HÄNSEL. (lachend)

Bl. *fp cresc. f*

141

Example 4. Nibbling, from Humperdinck, *Hänsel und Gretel*, act III, scene 3. Engelbert Humperdinck, *Hänsel und Gretel* (vocal score by Horst Gurgel). © 1972 Edition Peters. Used by permission.

(a) 135+1

He. 

Knus - per, knus - per Knäus - chen, wer knus - pert mir am Häus - chen?

(b) 137

G. 

O köst - li - cher Ku - chen, wie schmeckst - du nach mehr! Mir

Example 5. Initial taste, from Humperdinck, *Hänsel und Gretel*, act III, scene 3: (a) nibble theme; (b) sugar theme. Engelbert Humperdinck, *Hänsel und Gretel* (vocal score by Horst Gurgel). © 1972 Edition Peters. Used by permission.

all pretense (Example 7a) and freezes them with a spell. The passage's metric state, shown to the left of the example, displays a central duple diagonal (the eighth-, quarter-, and half-note levels), triple hypermeter, and triplet sixteenths. One could say that the witch's display of force lays bare a stark reality manifested in the central duple diagonal, while hints of her evil designs lurk in the triple hypermeter and motivic triplet sixteenths.

Soon afterward, the witch cages and feeds Hansel (Example 7b). She reverts to cloying sweetness, a falseness that is expressed metrically in 9/8, the central triple diagonal, with duple hypermeter and sixteenth notes perhaps reminding us of the reality of Hansel's spellbound and imprisoned state. As shown in Figure 9a, the two metric states just discussed are V-related, once again paralleling a dramatic opposition, here of plain reality versus sugary deception. But, as shown in Figure 9b, these two metric states can also be understood as an H-relation, mirroring one another across a horizontal axis. This alternate geometric interpretation suggests an alternate dramatic one: in addition to opposing reality and deception, the passage displays flip sides of a single coin—the witch's manipulation of the children, first by force and then by entreaty.

Parsifal

In Wagner's *Parsifal* (1881), the guileless youth Parsifal encounters the knights of the Holy Grail in the forest. The knights are in a woeful state

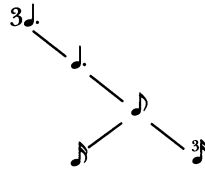

(a)

He. (Gretel tritt heran) 186

Sollst in den Back-o-fen huk-ken und nach den Leb-ku-chen guk-ken.

(b)

H. (Gretel zaudert) 187 HÄNSEL. (aus dem Stall schleichend)

Schwe-ster-lein, hüt dich fein!

Example 6. Checking oven, from Humperdinck, *Hänsel und Gretel*, act III, scene 3:
 (a) checking pastries; (b) stalling for time. Engelbert Humperdinck, *Hänsel und Gretel*
 (vocal score by Horst Gurgel). © 1972 Edition Peters. Used by permission.

because their leader, Amfortas, seduced by Kundry, has lost the holy spear to the evil sorcerer Klingsor and thereby sustained an incurable wound. Arriving at Klingsor's magic castle, Parsifal resists Kundry's wiles, and by his virtue regains the holy spear and destroys the castle. He returns to the knights and redeems them by restoring the spear, healing Amfortas, and fulfilling the office of minister of the Grail.

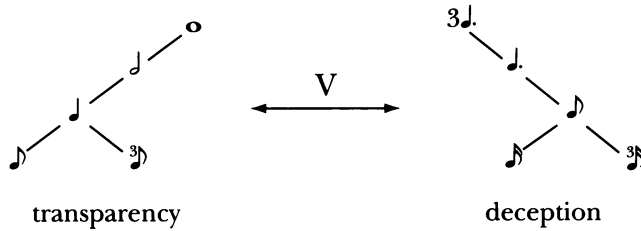

Figure 8. V-relation between Examples 4 and 6

I shall focus on Kundry's seduction of Parsifal in act II, scene 2. Kundry speaks to Parsifal of his childhood, his departure from his mother, Herzeleide, and her resulting death from sorrow. Parsifal responds to the news of his mother's death in anguish, and Kundry plays on Parsifal's distress in order to seduce him.

I begin by tracing the metric states of Kundry's aria, which outlines Parsifal's life through the eyes of Herzeleide. (As Humperdinck did, Wagner juxtaposes compound and simple meters, using dotted-quarter notes and plain quarter notes for the same tactus pulse.) Kundry's story begins (Example 8) with Herzeleide's care for Parsifal as a baby, in 6/8 meter with triple hypermeter.¹⁷ The description of Herzeleide's anxious protection of Parsifal (Example 9) accompanies a change to duple hypermeter. As shown in Example 10, 9/8 meter and duple hypermeter depict the dangers from which Herzeleide would shield Parsifal. (I have shown the duple hypermeter with arrows: strong points occur at the beginning of the vocal phrase in m. 871, and at the local harmonic resolutions at m. 873 and m. 875; the hypermeter shifts location halfway through the passage.)¹⁸ When Parsifal ventures away from home (Example 11), Herzeleide's distress occurs in 6/8 with duple hypermeter, as Amelia Kaplan (2000, 5) points out, although Wagner continues to notate the passage in 9/8. When Herzeleide finds Parsifal (not shown), she wraps him in a metrically ambiguous embrace containing elements of 3/8, 6/8, and 9/8 patterning.

At this point (Example 12a) Kundry addresses Parsifal directly: "Were you perhaps afraid of her kisses?" Wagner highlights this shift in focus, from Herzeleide to Parsifal, with a sudden paring away of surface activity and introduction of simple subdivisions in 3/4 meter.¹⁹

¹⁷ Wagner sets this portion of Kundry's story as a 6/8 lullaby, as William Rothstein pointed out to me.

¹⁸ One can hear mm. 870–75 in triple hypermeter, with strong measures at m. 870 and 873, but metric changes immediately preceding the passage weaken the metric strength of m. 870, despite the textural change at that point.

¹⁹ Example 12 shifts quite quickly from one metric state to another. As a result, some of the metric states that I analyze here iterate their top-level pulse only once or twice. In these cases, the metric state's top level represents not an ongoing metric pulse as much as the duration between strong beats on that level.

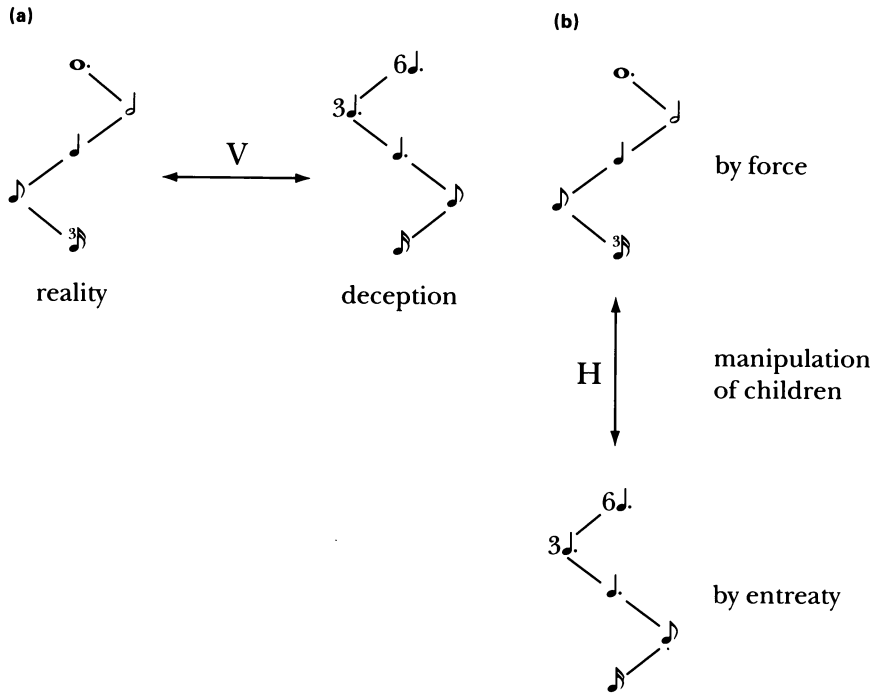

Figure 9. V- and H-relations between Examples 7a and 7b: (a) V-relation (b) H-relation

The rhetorical question brings Kundry to the point of her story. In Example 12b, she portrays Herzeleide's anguish at Parsifal's final departure in 9/8 and triple hypermeter. Herzeleide's death from sorrow follows in Example 12c–e; I shall discuss this passage shortly. Parsifal responds (Example 12f) to the news of his mother's death with great distress, in 4/4 and duple hypermeter.

Kundry plays on Parsifal's remorse in order to seduce him. She presents love as consolation for his pain, and herself as the embodiment of that love. In a deceptive twist (Example 13), she paints her kiss as a token of Herzeleide's last blessing. Example 13a shows the primarily duple metric state occurring at the words "mother's blessing," and Example 13b, that at the kiss itself.

Kaplan (2000) demonstrates that, in this opera, characters' virtuous and evil ethical states associate with duple and triple metric factors, respectively. For instance, Parsifal's unthinking abandonment of his mother and her grief occur in primarily triple factors, and Parsifal's anguished response takes place in pure duple ones. This association is by no means unproblematic, however—Klingsor's summoning of Kundry to seduce Parsifal occurs in primarily duple factors, for instance—and I propose that dramatic content in act II, scene 2, links more clearly to *relations* between metric states than to the duple or triple content of the states per se.

825

Ich sah das Kind an sei - ner Mut - ter
I saw the child u - pon its moth - er's

828

Brust, sein er - stes Lal - len lacht mir noch im Ohr:
breast, its coo - ing cries still lin - ger in my ear:

Example 8. From Wagner, *Parsifal*, act II, scene 2. *Parsifal* by Richard Wagner. English Translation by Stewart Robb. Copyright © 1962 (Renewed) by G. Schirmer, Inc. (ASCAP). International Copyright Secured. All Rights Reserved. Reprinted by Permission.

Figure 10 sums up these main metric states, building upon, revising, and considerably extending Kaplan's example 4.²⁰ The metric states are shown as ski paths near the bottom of the example. They are keyed, at the top of the example, to the score examples that I have just discussed and, just below that, to the libretto's content. (The example runs across two pages.) Kundry's aria consists of two primary sections, the first, spanning the example's first page, telling of Herzeleide's care for Parsifal and determination to shield him from harm, and the second, beginning the example's second page, describing Parsifal's final departure and Herzeleide's death from sorrow. The example continues with the beginning of Parsifal's lament and then the climax of Kundry's seduction attempt.

²⁰ Kaplan's example 4 charts the metric states of mm. 825–901, listing factors between five pulse levels from subactus to "period" (hyper-hypermeter). The metric states in my Figure 10 differ from Kaplan's in the following respects: (1) I disregard Kaplan's period level because it sometimes conflates grouping and metric structure, and because its musical articulation tends to be ambiguous; (2) in mm. 892–901, a crucial turning point in Kundry's aria, I

find two distinct metric states whereas Kaplan finds a single metric state of four triple factors extending from subactus to period; and (3) I extend the analysis farther into the scene, while Kaplan's example 4 ends at m. 902. (Kaplan mentions the 4/4 meter of Parsifal's response in m. 916ff. and of Kundry's "impersonation" of Herzeleide in m. 979ff. but does not analyze their metric states further.)

(848)

den Schlum - mer be - wacht der Mut - ter
pro - tect - ed its rest with sleep - less

851

Seh - nen, den weckt' am Mor -
vi - gil, and in the the morn -

Example 9. From Wagner, *Parsifal*, act II, scene 2. *Parsifal* by Richard Wagner. English Translation by Stewart Robb. Copyright © 1962 (Renewed) by G. Schirmer, Inc. (ASCAP). International Copyright Secured. All Rights Reserved. Reprinted by Permission.

The metric states are labeled just underneath the ski paths with letters.²¹ (On the first page, X indicates metrical or hypermetrical ambiguity; on the second page, U indicates the union of two ski paths.) Each metric state associates with a particular dramatic situation: B depicts Herzeleide's protective anxiety, while C portrays the dangers that she fears. One can view B and C simply as 6/8 and 9/8 meters in duple hypermeter; one can also interpret B and C as H-related, reflecting one another across a horizontal axis. This H-relation illustrates the duality of the dramatic situation, setting Herzeleide's anxious care for Parsifal against its flip side—the dangers from which she wishes to shield him.

Metric state D, at the end of the first page, concludes Kundry's narration of Parsifal's childhood. State D mirrors the aria's opening state A around the vertical axis, as well as around the horizontal axis. Once again, the metric relations parallel dramatic ones: the V-relation suggests the contrast between Parsifal's reaction to Herzeleide's anxious affection (state D) and her care

²¹ B more precisely labels a ski-path shape rather than a specific metric state, since it occurs in two different tempi, the *sehr mässig* of m. 825ff. and the *etwas belebend* of m.

858 ff. Since the remaining labels refer to particular metric states and their relations, for simplicity I use the term metric state throughout this discussion.

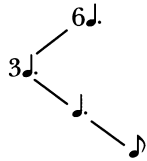

870

bot. Den Waf - fen fern, — der Män - ner Kampf und Wüt - hen.
his. Her dear de - sire — was all to keep you shel - tered.

873

woll - te sie still dich ber - gen und be - hü - ten.
far — from all arms, and man - kind's war - ring mad - ness.

876

Nur Sor - gen war — sie, ach! und Ban - gen:
She loved — you, watched you, and still sor - rowed:

879

nie — soll - te Kun - de
all — news — of e - vil

Example 10. From Wagner, *Parsifal*, act II, scene 2. *Parsifal* by Richard Wagner. English Translation by Stewart Robb. Copyright © 1962 (Renewed) by G. Schirmer, Inc. (ASCAP). International Copyright Secured. All Rights Reserved. Reprinted by Permission.

Example 11. From Wagner, *Parsifal*, act II, scene 2. *Parsifal* by Richard Wagner. English Translation by Stewart Robb. Copyright © 1962 (Renewed) by G. Schirmer, Inc. (ASCAP). International Copyright Secured. All Rights Reserved. Reprinted by Permission.

for him (state A); the H-relation illustrates the duality between Parsifal's later independence from his mother and his dependence on her as an infant. This first page of the example, then, features pairs of metric states: A with D, and B with C.

Parsifal's disregard for Herzeleide's anxiety eventually leads to her death. On the second page, metric states E and E' accompany Herzeleide's pain and hopelessness at Parsifal's final departure. These two states, strongly linked by their metric structure as well as their dramatic associations, feature triple factors at almost all levels, including an added lower level created by an ominous triplet-sixteenth motive.

States F and G, accompanying Herzeleide's fruitless waiting and eventual death, bring together earlier states whose dramatic associations comment on the causes of Herzeleide's suffering. State F (Herzeleide's waiting) unites metric states C (dangers feared) and D (Parsifal's disregard of Herzeleide's care): Parsifal's blithe departure into the world's dangers results in Herzeleide's anguished waiting. State G (Herzeleide's death), marked *sehr langsam*, slows down state B (Herzeleide's anxiety and distress) to a sorrowful death and combines it with state D (Parsifal's reaction to his mother's protectiveness), hinting at Parsifal's thoughtlessness as the cause of his mother's death. (This state D, though notated in half values, is generally performed at the same tempo as before: the eighth note at m. 910 roughly equals the vocal quarter note at m. 892.)

Kundry's aria ends here, and only E and E', the predominantly triple metric states of Herzeleide's pain, remain unpaired. With J and J', Parsifal answers them with duple metric states of his own distress. J reflects E' across a vertical axis, and J' (almost) reflects E across a vertical axis, creating two V-related pairs that set Parsifal's current remorse against his mother's past pain. (The difference in tempo between Parsifal's J states (*bewegter*) and his mother's E states makes dramatic sense: Parsifal is responding in the first-person present to Kundry's story in the third-person past.)

(a) (b)

892 KUNDRY

ward dir es wohl gar beim Küssen bang? Doch, ihr
 what fear did you have of kisses then? Yet you

Wieder etwas mehr zurück.

897

We-he du nicht ver-nahm'st, nicht ih-rer Schmer-zen To-ben als
 could not see her sor-row, nor know that fren-zied anguish. Then

Etwas belebend. *Wieder weniger*

3m. = 9♩
 6m. = 18♩

(c)

900

end-lich du nicht wie-der kam'st und dei-ne Spur ver-sto-ben.
 at last you went for all time, and left no trace be-hind you.

Etwas belebend.

903

Sie harr-te Näch't und Ta-ge, bis ihr ver-stummt die Kla-ge, der
 She wait-ed for you dai-ly, un-till her woe was si-lenced, un-

Allmählich wieder langsamer.

più p

Example 12. From Wagner, *Parsifal*, act II, scene 2. *Parsifal* by Richard Wagner. English Translation by Stewart Robb. Copyright © 1962 (Renewed) by G. Schirmer, Inc. (ASCAP). International Copyright Secured. All Rights Reserved. Reprinted by Permission.

(d)

907

Gram — ihr zehr-te den Schmerz, um stil-len Tod sie warb: ihr
 til — all was dull and dead. — She prayed for death to come, then

Sehr langsam.

(e)

911

brach das Leid das Herz, — und Her-ze-lei-de
 sor-row broke her heart, — and Heart of Sor-row

(f)

915

PARSIFAL

starb. We-he! We-he!
 died. Sor-row! Sor-row!

Bewegter, doch nicht schnell.

918

Was that ich? Wo war ich? Mut-ter!
 My mis-deed? Where was I? Mo-ther!

espressivo

Example 12. (cont.) From Wagner, *Parsifal*, act II, scene 2. *Parsifal* by Richard Wagner. English Translation by Stewart Robb. Copyright © 1962 (Renewed) by G. Schirmer, Inc. (ASCAP). International Copyright Secured. All Rights Reserved. Reprinted by Permission.

Example 12. (cont.) From Wagner, *Parsifal*, act II, scene 2. *Parsifal* by Richard Wagner. English Translation by Stewart Robb. Copyright © 1962 (Renewed) by G. Schirmer, Inc. (ASCAP). International Copyright Secured. All Rights Reserved. Reprinted by Permission.

What is more, K and K', the concluding metric states of Kundry's seduction, reflect E and E', the final states of Herzeleide's grief, across the horizontal axis. Metric state K of Herzeleide's putative blessing complements state E of Herzeleide's anguish, and state K' of the kiss itself transforms state E' of Herzeleide's hopelessness. In this way, through H-relations, the climax of the seduction scene as a whole transforms the point of greatest tension in Kundry's preceding story. Herzeleide's unanswered grief finds answer first in the V-relations of Parsifal's lament, and then in the H-relations of Kundry's impersonation of her blessing.²²

It seems, in this scene at least, as summarized in Figure 11a, that V-relations portray oppositions that *differ*—Herzeleide's care and Parsifal's reaction to it, Herzeleide's pain and Parsifal's remorse—while H-relations

²² The V-relation between E' and J, and the H-relation between E' and K' are asserted as such on the basis of the relations between the *pairs* E/E' and J'/J, and E/E' and K/K'. E was paired with E', J with J', and K with K' because in each case the two states share many metric levels and differ only on their peripheries; dramatic associations support these three pairings. In this context, because E and J' are

basically V-related, I view E' and J as V-related (although the latter can also be H-related). Similarly, because E and K are H-related, I understand E' and K' to be H-related (although the latter can also be V-related). In other words, I have let the relation that holds for both members of a pair determine the individual relations.

(a)

978

heut' als Mut - ter - se - gen's letz - ten Gruss - der Lie - be er - sten
 me - her fi - nal - bless - ing and fare - well: she gives you love's first

Gedehnt. Immer langsamer.

piu p pp p ppp *ersterbend*

983

Kuss!
 kiss!

Sehr langsam.

pp pp

(b)

Example 13. From Wagner, *Parsifal*, act II, scene 2. *Parsifal* by Richard Wagner. English Translation by Stewart Robb. Copyright © 1962 (Renewed) by G. Schirmer, Inc. (ASCAP). International Copyright Secured. All Rights Reserved. Reprinted by Permission.

represent two sides of the same coin—Parsifal’s dependence on Herzeleide as an infant and his independence from her later on, Herzeleide’s protectiveness and the dangers from which she shields Parsifal, Herzeleide’s pain and her putative final blessing. Metric states that can be related by both V and H (indicated by asterisks) associate with dramatic content that can be interpreted in

Ex.	8	9	10	10 cont.	11	12a
m.	825	849	870	876	884	890 892
	KUNDRY: HERZELEIDE'S CARE FOR PARSIFAL					
subject	infancy	anxious care	shield from violence	shield from knowledge	distress at wandering	embrace fear of kisses?
tempo	Sehr mässig und ruhig		sorrow over father's death, determination to protect child			
metric state						
	A Herzeleide's care infant's dependence	B protective anxiety	C=HB dangers feared	C=HB dangers feared	B	D=VA=HA Parsifal's reaction Parsifal's independence
						X

Figure 10. Wagner, *Parsifal*, act II, scene 2—metric states.

(a)



(b)

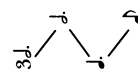
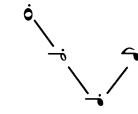
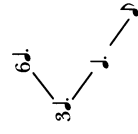
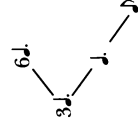
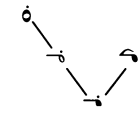
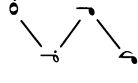
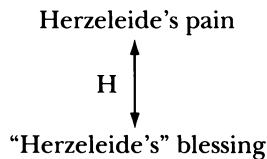
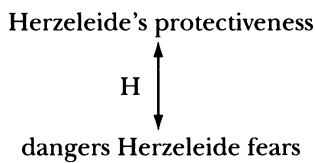
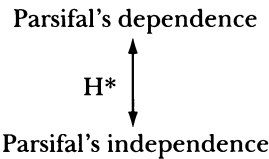
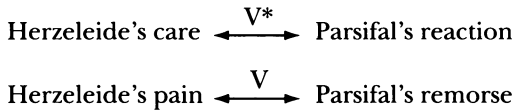
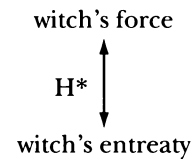
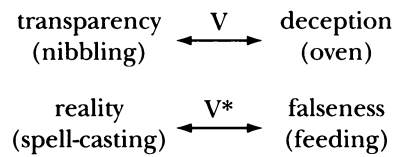

Figure 11. Metric-dramatic relations: (a) *Parsifal*; (b) *Hänsel und Gretel*

terms of both types of opposition: the V-relation depicting Herzeleide's care and Parsifal's reaction can also be understood as the H-relation paralleling Parsifal's early dependence and later independence.

Reviewing the *Hänsel und Gretel* examples, as shown in Figure 11b, we see that Humperdinck uses V and H in similar ways. V sets the transparency of the initial nibbling scene against the duplicity of the oven scene, and the stark reality of the spell-casting scene against the falseness of the feeding scene. The latter opposition, reinterpreted as H, shows two sides of the witch's attempt to control the children—by force and by endearment.

* * *

These passages suggest ways in which both Wagner and Humperdinck use metric states as bearers of meaning, and exploit particular metric relations to signal certain dramatic ones. Although these metric relations can be quite abstract, it was a perceived aural similarity between the two works that led me to examine them. Only after my analysis revealed similarities in metric

structure did I learn that Humperdinck greatly admired Wagner and had a particular connection to *Parsifal*: he served as Wagner's closest assistant during the work's preparation and even provided some music for a scene change at its premiere.²³ Thus, development and application of my model of metric symmetries served to corroborate my musical intuition and specify sophisticated ways in which the two operas resemble one another metrically.

Hänsel und Gretel and *Parsifal* also share many surface rhythmic characteristics. Both frequently display a metric fluidity that contrasts duple and triple on lower levels while keeping higher levels constant (*Parsifal*'s 3/4 versus 9/8, or *Hänsel und Gretel*'s 2/4 versus 6/8, for example); the contrasting subdivision factors occur either successively or concurrently. Both use a "shimmer" figuration effect that tends to connote the supernatural (the effect is created by fast-moving triplet-eighth or triplet-sixteenth notes whose pitch alternation groups the notes in twos), and both employ syncopated accompaniments in formal transitions and other mobile passages. The two works even display distinctive motivic similarities: compare the ominous triplet-sixteenth motive in *Parsifal* (Example 12b) with the flames/spell motive of *Hänsel und Gretel* (Example 7a, also reh. 167+4).

Although they clearly differ in the gravitas of their treatments, the two operas also share a common plot schema. Both take place in a forest setting, with a group of people (the knights of the Grail, the gingerchildren) oppressed by evil magic. Innocent protagonists (*Parsifal*, Hansel and Gretel) overcome temptation to defeat an evil magician (Klingsor, the witch), destroying his/her work (the magic castle, the gingerbread house) and bringing healing and redemption to his/her victims.

Music and drama are also closely intertwined in both works. Both composers center their musical and dramatic action on leitmotifs whose musical characteristics change in correspondence to dramatic and psychological developments; rhythmic-metric transformations form one aspect of this kind of musical depiction.

To summarize, *Hänsel und Gretel* and *Parsifal* resemble one another in their rhythmic surfaces, their plots, their linkage of drama and music, and their associations (to some degree) of duple/triple factors with good/evil. These correspondences do not necessarily imply my findings, namely, that certain metric symmetries associate with certain dramatic ones. The two composers' use of particular metric states whose ski paths fit into the systems defined by my symmetries, and whose symmetric relations parallel dramatic ones, articulates a correspondence between the two works' metric-dramatic structures much more precise than that implied by the more general similarities described above. My model of metric spaces, symmetries, and systems

²³ Engelbert Humperdinck 1907. For a comprehensive account of Humperdinck's interactions with Wagner, see Eva Humperdinck and Evamaris 2000, 17–69; see also

Eva Humperdinck 1996; and Wolfram Humperdinck 1965, 109–25.

facilitated the discovery of these metric strategies by (1) modeling dissonant metric states as single states, thereby facilitating their comparison; (2) conceptualizing relations among metric states in terms of certain symmetries; and (3) generalizing such symmetries as operations on ski-path *shapes*, thereby producing simple systems that encompass metric states in all possible tempi.

Related issues

In my focus upon the ski-path *shapes* related by the symmetries r_0 , r_{180} , V , or H , I have neglected a useful aspect of my model. Representation of metric states as ski paths, rather than merely as factor representations, neatly encapsulates both the factors and the pulse levels involved. In other words, a path's *shape* displays its factors in geometric form, while its *location* on a ski graph specifies its pulses.

The information contained in a ski path's shape and location suggests several ways to connect the theory to perception. One could take into account the tempo thresholds posited for different levels of a metric hierarchy²⁴ and their effects on a listener's experience of a particular metric state. Questions of perception also feed into issues of similarity between metric states: one could develop similarity measurements that consider common pulses (as Cohn does), common factors (as Murphy does), and common tactus locations, both relative (position within the levels of a metric state) and absolute (actual tempo). Initial exploration shows such similarity measurements to be a useful means of detailing the relationship between two metric states, whether or not the states relate by one of the symmetries posited here.

In conclusion, I have presented a new model for metric states and their relationships, one that complements previous work in the area. Application of the states, symmetries, and systems of my model to Humperdinck's *Hänsel und Gretel* and Wagner's *Parsifal* has revealed heretofore hidden metric-dramatic links between the two works.

Works Cited

- Cohn, Richard. 1992a. "The Dramatization of Hypermetric Conflicts in the Scherzo of Beethoven's Ninth Symphony." *19th-Century Music* 15: 188–206.
- . 1992b. "Metric and Hypermetric Dissonance in the *Menuetto* of Mozart's Symphony in G minor, K. 550." *Integral* 6: 1–33.
- . 2001. "Complex Hemiolas, Ski-Hill Graphs and Metric Spaces." *Music Analysis* 20: 295–326.

²⁴ Based on experimental literature, London (2002a; 2004, 27–47) summarizes these tempo thresholds as follows: 100 ms is the fastest periodicity perceptible as a pulse subdivision, 200–250 ms roughly the fastest periodicity perceptible

as a tactus, 2 s the slowest periodicity perceptible as a tactus, and 5–6 s the slowest periodicity perceptible as a pulse grouping, with approximately 600 ms forming a preferred tactus periodicity.

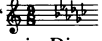
- Humperdinck, Engelbert. 1907. "Parsifal-Skizzen." *Die Zeit*. Reprinted and annotated in *Parsifal-Skizzen*, ed. Eva Humperdinck and M. Evamaris, 3–16. Koblenz: Görres, 2000. Translated [n.t.] as "Parsifal Sketches" in *Wagner* 16 (1995): 91–104.
- Humperdinck, Eva. 1996. *Engelbert Humperdinck in seinen persönlichen Beziehungen zu Richard Wagner . . . , dargestellt am Briefwechsel und anderen Aufzeichnungen*. Koblenz: Görres.
- Humperdinck, Eva and M. Evamaris. 2000. "Alle Begegnungen Engelbert Humperdincks mit Richard Wagner von 1880 bis 1883." In *Parsifal-Skizzen*, 17–69. Koblenz: Görres.
- Humperdinck, Wolfram. 1965. *Das Leben meines Vaters*. Frankfurt: Waldemar Kramer.
- Irmen, Hans-Josef. 1989. "Die Musik und ihre folkloristischen Quellen." In *Hänsel und Gretel: Studien und Dokumente zu Engelbert Humperdincks Märchenoper*, 89–104. New York: Schott.
- Kaplan, Amelia. 2000. "Meter and Hypermeter as a Means of Signification in Wagner's *Parsifal*." Paper presented at the Society for Music Theory Conference, Toronto.
- Lewin, David. 1987. *Generalized Musical Intervals and Transformations*. New Haven: Yale University Press.
- Lippard, Erin. 2005. "Metric Concepts in the Third Act of Humperdinck's *Hänsel und Gretel*." Paper written for graduate seminar "Metric Conflict," University of Colorado at Boulder.
- London, Justin. 2002a. "Cognitive Constraints on Metric Systems: Some Observations and Hypotheses." *Music Perception* 19: 529–50.
- . 2002b. "Some Non-Isomorphisms between Pitch and Time." *Journal of Music Theory* 46/1–2: 127–51.
- . 2004. *Hearing in Time*. Oxford: Oxford University Press.
- MacDonald, Hugh. 1988.  "19th-Century Music 11: 221–37.
- Malin, Yonatan. 2003. "Metric Dissonance and Music-Text Relations in the German Lied." Ph.D. diss., University of Chicago.
- Murphy, Scott. 2006. "Metric Cubes and Metric Transformations in Some Music of Brahms." Paper presented at the Society for Music Theory Conference, Los Angeles.

Recordings Cited

- Ameling, Elly, soprano, and Norman Shetler, piano. 1995 remaster of 1967. *Elly Ameling: The Early Recordings*, vol. 3. BMG Classics BM 610.
- Fassbaender, Brigitte, mezzo-soprano, and Irwin Gage, piano. 1982. *Lieder von Johannes Brahms*. RCA 40 23 507.
- Fischer-Dieskau, Dietrich, baritone, and Karl Engel, piano. 1995. *Les Introuvables de Dietrich Fischer-Dieskau*. EMI Classics CDZF 68509. (*Von ewiger Liebe* recorded 1959.)
- Flagstad, Kirsten, soprano, and Edwin McArthur, piano. n.d. *A Song Recital*. RCA Victor LM 1738.
- Norman, Jessye, soprano, and Geoffrey Parsons, piano. 1980. *Brahms Lieder*. Philips 9500 785.

Daphne Leong is associate professor of music theory at the University of Colorado at Boulder. Her research has focused on rhythm, analysis and performance, and the music of Béla Bartók. Leong is also an active pianist and chamber musician. 